

SIEMENS



SIMATIC

S7-1500 / ET 200MP

Automation system

In a nutshell

Edition

10/2016

siemens.com

1 Comparison of SIMATIC automation systems

The tables below compare the main technical specifications of the SIMATIC systems.

	Basic Controller	Distributed Controller	
	SIMATIC S7-1200	SIMATIC ET 200SP CPU	SIMATIC ET 200SP Open Controller 1515SP PC
Data work memory, max.	150 KB	1 MB	5 MB
Code work memory, max.		200 KB	1 MB
Load memory/ mass storage, max.	4 MB	32 GB (via memory card)	320 MB
I/O address area, max.	1024/1024 bytes	32 / 32 KB	32 / 32 KB
Integrated interfaces, max.	1 x PROFINET IO (2-port switch)	1 x PROFINET IO (2-port switch) 2 x PROFINET	1 x PROFINET IO (2-port switch) 1 x PROFINET 1 x PROFIBUS
Controller with integrated inputs and outputs	X	---	---
Configuration control	---	X	X
Web server	X	X	X
Isochronous mode	---	X	X
Integrated display	---	---	X (as Windows application)
Technology integrated	Motion Control PID Control	Motion Control PID Control	Motion Control PID Control
Security integrated	X	X	X
Integrated system diagnostics	X	X	X
Integrated safety functionality	X	X	X
Degree of protection	IP20	IP20	IP20

	Distributed Controller	Advanced Controller	
	SIMATIC ET 200pro CPU 1516pro-2 PN	SIMATIC S7-1500	Software Controller SIMATIC S7-1500
Data work memory, max.	5 MB	20 MB	20 MB
Code work memory, max.	1.5 MB	6 MB	5 MB
Load memory/ mass storage, max.	32 GB (via memory card)	32 GB (via memory card)	320 MB
I/O address area, max.	32 / 32 KB	32 / 32 KB	32 / 32 KB
Integrated interfaces, max.	2 x PROFINET IO (3 ports)	2 x PROFINET IO 1 x PROFINET 1 x PROFIBUS	1 x PROFINET IO 1 x PROFINET 1 x PROFIBUS
Controller with integrated inputs and outputs	---	C-CPU	---
Configuration control	X	X	X
Web server	X	X	X
Isochronous mode	X	X	---
Integrated display	---	X	X (as Windows application)
Technology integrated	Motion Control PID Control	Motion Control PID Control C-CPU: High-speed counters, PWM, PTO, frequency output	Motion Control PID Control
Security integrated	X	X	X
Integrated system diagnostics	X	X	X
Integrated safety functionality	X	X	X
Degree of protection	IP65/67	IP20	Depending on hardware

2 Component selection

2.1 Quickly find the right component

To configure a SIMATIC S7-1500 automation system, select the appropriate components according to performance, configuration limits, communication interfaces and the size of the application. Below you can find an initial overview for component selection:

1. Mounting rail



Select:

- Length of the mounting rail

You can find all relevant information in Section 6.

2. Controller



Select:

- Standard CPU, compact CPU, fail-safe CPU or technology CPU
- Mounting size
- Number of PROFIBUS/PROFINET interfaces
- Suitable work memory

You can find all relevant information in Section 7.

3. Input/output modules



Select:

- Number of inputs/outputs
- Direct voltage/alternating voltage
- Measuring function
- Output function
- Type of temperature measurement

You can find all relevant information in Section 9.

4. Communication modules



Select:

- Bus system
- Communication interfaces
- Protocols for data exchange

You can find all relevant information in Section 10.

5. Technology functions



Select:

- Motion Control
- PID Control
- Counting
- Position detection
- Time-based IO

You can find all relevant information in Section 11.

6. Power supply



Select:

- Load power supply
- System power supply

The load power supply provides the voltage for the CPU and can also provide power to the interface modules. For larger plants, a system power supply is required in addition.

You can find all relevant information in Section 12.

7. Connection elements



Select:

- Front connector for flexible wiring with screw or plug-in system
- Shield terminals and shield brackets for connecting cable shields

You can find all relevant information in Section 13.

8. HMI devices for the visualization



Select:

- HMI devices for machine-level process visualization and control

You can find an overview of the available HMI devices in the [Industry Mall](#).

9. TIA Portal engineering software



Select:

- SIMATIC STEP 7 for control programming, in addition possibly:
 - SIMATIC WinCC for the HMI device configuration
 - SINAMICS Startdrive for the drive parameter assignment
- Add-on packages, for example STEP 7 Safety Advanced for programming fail-safe controllers

You can find all relevant information in Section 14.

2.2 TIA Selection Tool

The [TIA Selection Tool](#) supports you in the selection of the components, the configuration of your system, and ordering.

3 The SIMATIC automation systems

You need optimum solutions for every application in order to automate your machines and plants economically and flexibly.

The SIMATIC controller portfolio includes a variety of systems:

- The SIMATIC S7-1200 Basic Controller is the intelligent choice for compact automation solutions with integrated communication and technology functions.
- If plant complexity and system performance are priorities, the SIMATIC S7-1500 automation system is the right choice for you. The SIMATIC S7-1500 controller builds on the more simple functionality of the SIMATIC S7-1200 Basic Controller and fulfills the highest demands on performance, flexibility and networking capability.
- The SIMATIC ET 200SP Distributed Controller combines the advantages of the S7-1500 and the very compact design of the ET 200SP with high channel density. This saves space in the cabinet and costs through the use of distributed intelligence.
The CPU 1516pro-2 PN offers you SIMATIC S7-1500 functionality in the design of the ET 200pro in the degree of protection IP65/IP67 for use outside the cabinet.
- If maximum precision and speed as well as PC-based automation are required, the SIMATIC S7-1500 Software Controller is used. The PC-based controller is autonomous from the operating system during operation.

The SIMATIC controllers are integrated into the Totally Integrated Automation Portal and offer consistent data management and a uniform operating concept. With its integrated functions, engineering in the TIA Portal ensures consistent functionality.

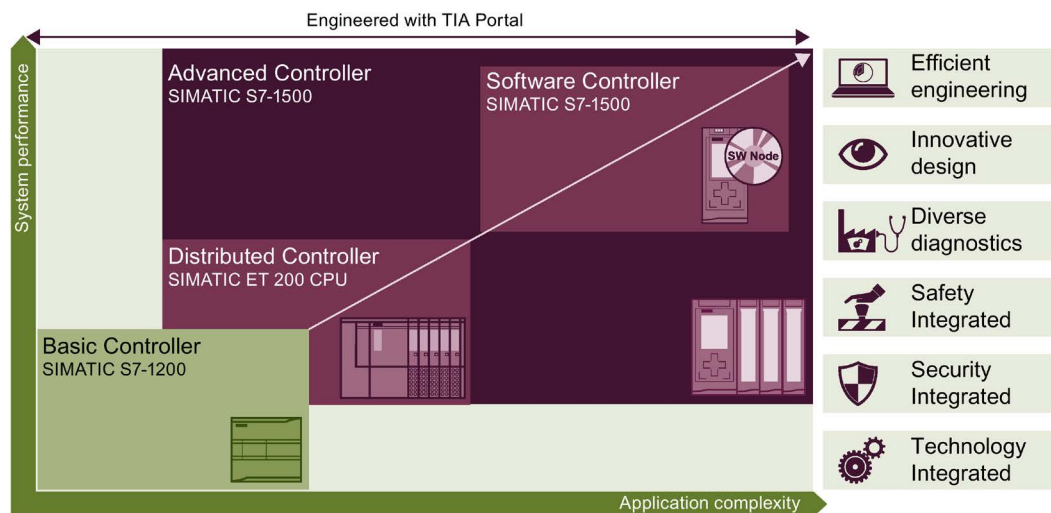

Overview of SIMATIC automation systems

The SIMATIC S7-1500 automation system supports all conventional communication standards.

All the SIMATIC S7-1500 CPUs offer integrated Motion Control functions. Technology CPUs are available for extended Motion Control functions.

The SIMATIC S7-1500 CPUs are also available as fail-safe controllers.

Diagnostic functions across all components simplify troubleshooting. Changes to the parameter assignment can be implemented quickly and easily with the integrated display.

Integrated security functions help against manipulation and know-how theft and offer additional security mechanisms for the configuration of secure networks.

4 Overview of SIMATIC S7-1500 system

4.1 Plant components and automation levels

The SIMATIC S7-1500 automation system complies with the high requirements on performance, integration and fail-safety. The combination of the individual SIMATIC components offers powerful and flexible automation solutions that cover all ranges of control applications:

- The process signals are connected to the central controller via fieldbus
- All modules are located directly in the automation system or in the distributed I/O system
- F-CPU with integrated safety functionality ensure fail-safe processes
- SIMATIC S7-1500 is intended for installation in the control cabinet with IP20 degree of protection

The SIMATIC S7-1500 is integrated across all communication standards consistently in the various automation levels.

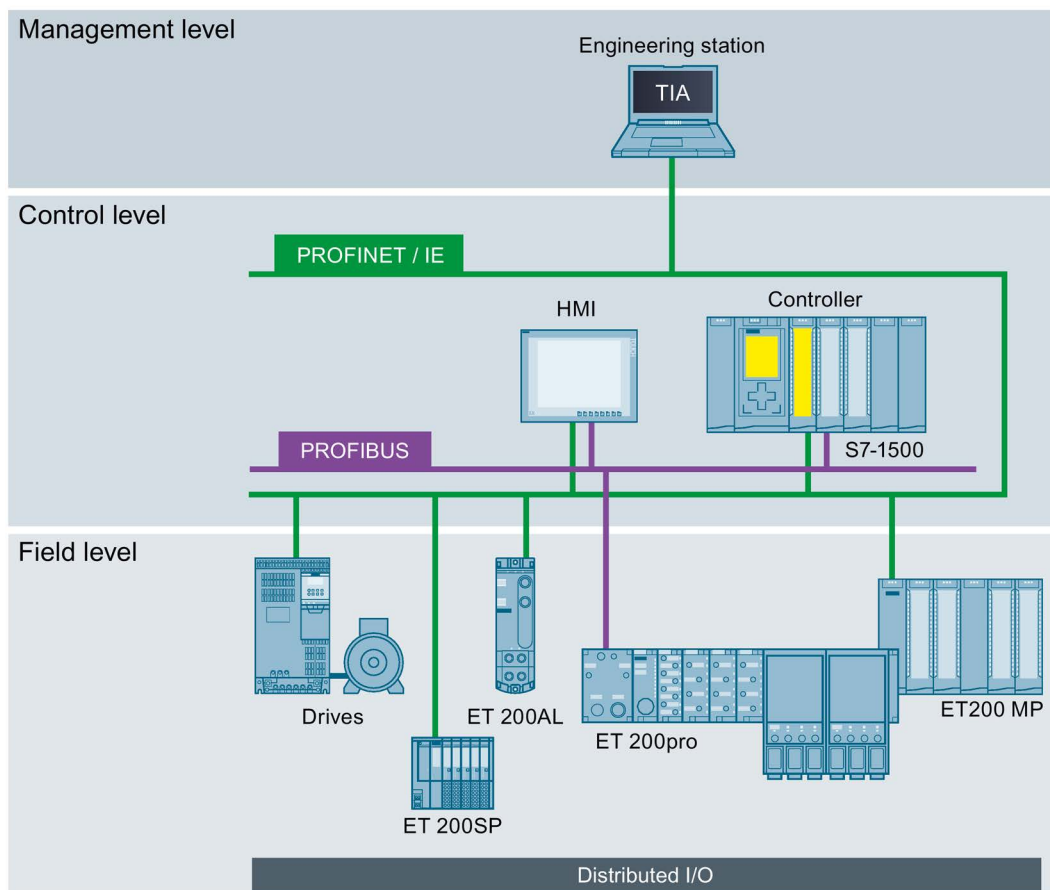

Basic structure: SIMATIC S7-1500 at management, control and field level

You can also find an overview of the SIMATIC S7-1500 automation system on the [Internet](#).

4.2 Scalability

In order to suit the requirements of your plant planning, the SIMATIC S7-1500 controllers can be scaled in their processing speed and configuration limits. They also offer networking facilities via different communications standards.

Safety Integrated, Motion Control, and other technology functions can be used for all plant sizes.

SIMATIC S7-1500 standalone system

SIMATIC S7-1500 with compact CPU 1511C-1 PN is cost-optimized and efficient. Digital and analog channels, fast counting functions and high-speed outputs, for example, for direct setpoint specification for step motors via PTO or for connection of valves via PWM, are already integrated in the CPU. The compact controller saves a great deal of space and can be used in small to medium-sized applications.

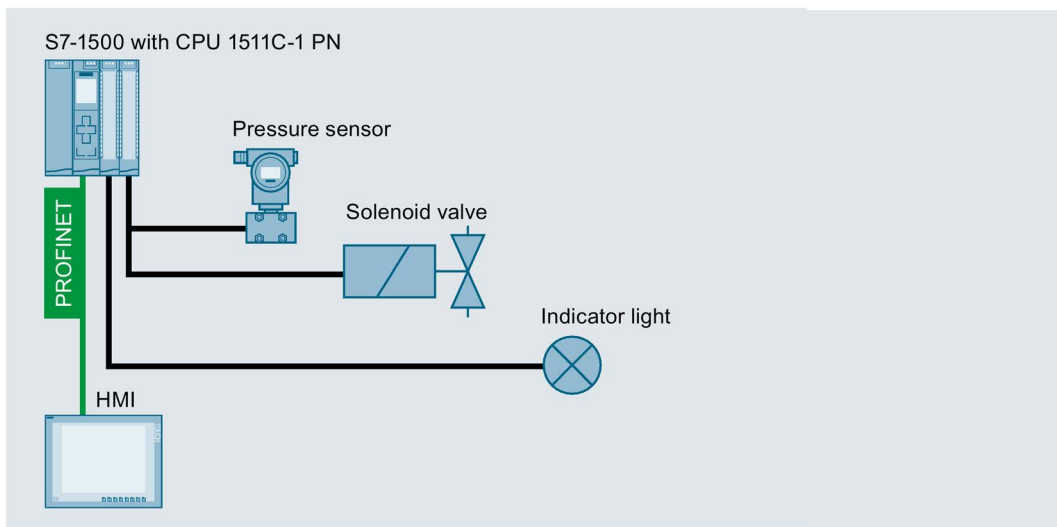

Example: Plant configuration with SIMATIC S7-1500 with integrated I/O

SIMATIC S7-1500 compact system

SIMATIC S7-1500 with CPU 1511-1 PN is the standard for small to medium-sized applications. A SIMATIC ET 200MP distributed I/O system is connected in the configuration example.

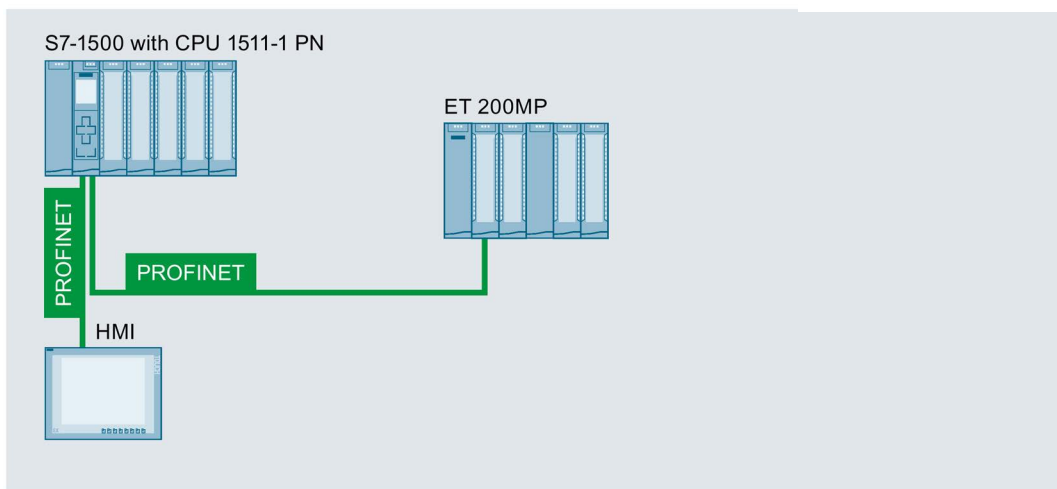

Example: Plant configuration with SIMATIC S7-1500 with I/O, ET 200MP and HMI device

SIMATIC S7-1500 standard system

SIMATIC S7-1500 with CPU 1516-3 PN/DP can be used for complex applications and communication tasks.

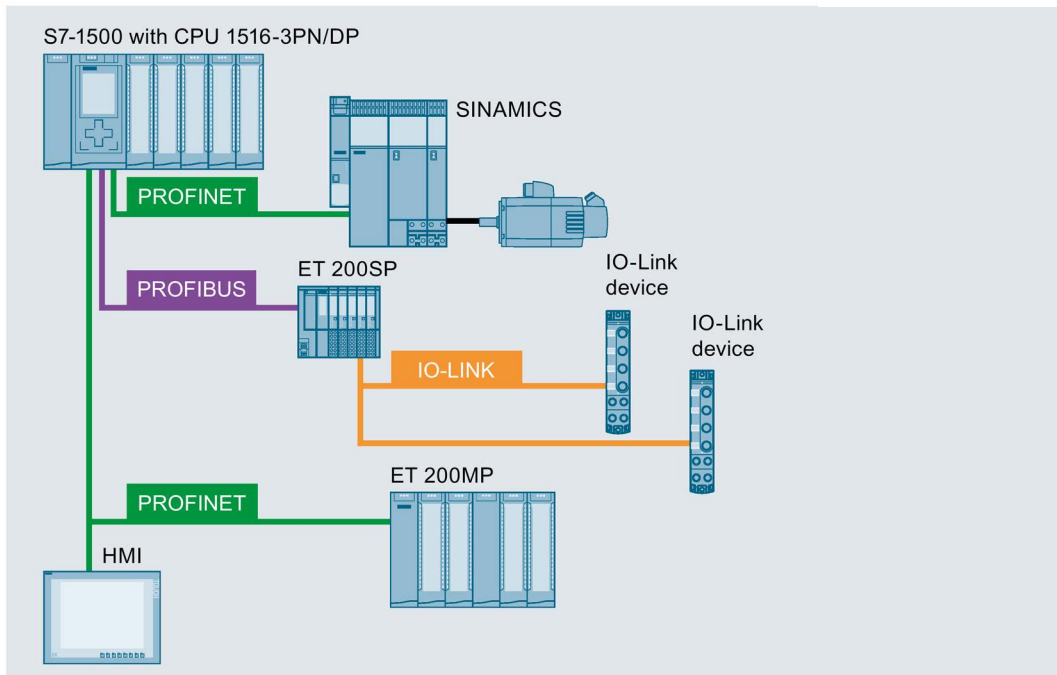

Example: Plant configuration with SIMATIC S7-1500, Motion Control, distributed I/O and IO-Link devices

Large plant with safety and WLAN integration

With safety-related applications via PROFINET communication and WLAN functionality, you make the right choice for large plants with high requirements regarding performance, communication, flexibility and fail-safety with S7-1500.

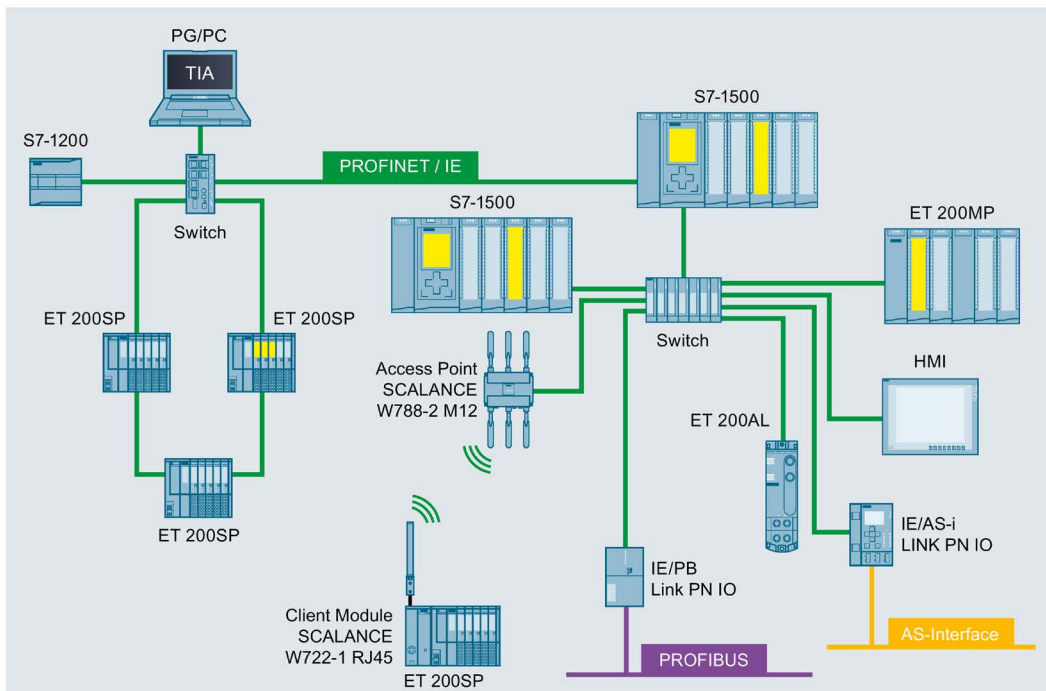

Example: Plant configuration with SIMATIC S7-1500 and Safety on PROFINET

5 Installation conditions

5.1 Structure

The modular SIMATIC S7-1500 automation system is optimized in its structure for control tasks and specially designed for ruggedness and long-term availability. The configuration consists of CPU and I/O modules. Depending on the size of the plant, additional system power supply modules supplement the configuration. The SIMATIC S7-1500 automation system can be powered via additional load power supply modules.

Sample configuration of SIMATIC S7-1500 system

The SIMATIC S7-1500 automation system consists of a single-row configuration in which all modules are installed on one mounting rail. The modules are connected by means of U connectors, and thus form a self-assembling backplane bus. A maximum of 32 modules can be plugged, on the slots 0 to 31.

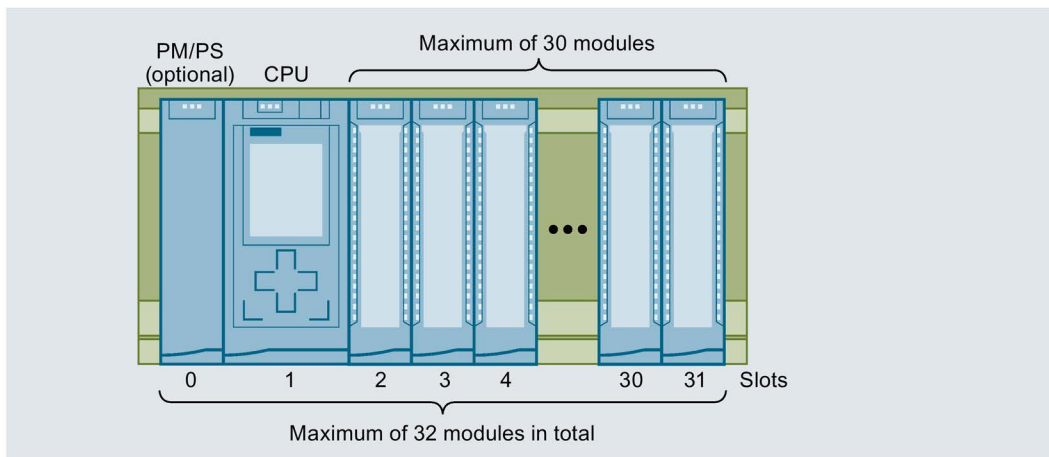

Maximum configuration of SIMATIC S7-1500 automation system

Sample configuration of ET 200MP distributed I/O system

You can use interface modules to add additional I/O modules to the ET 200MP distributed I/O system.

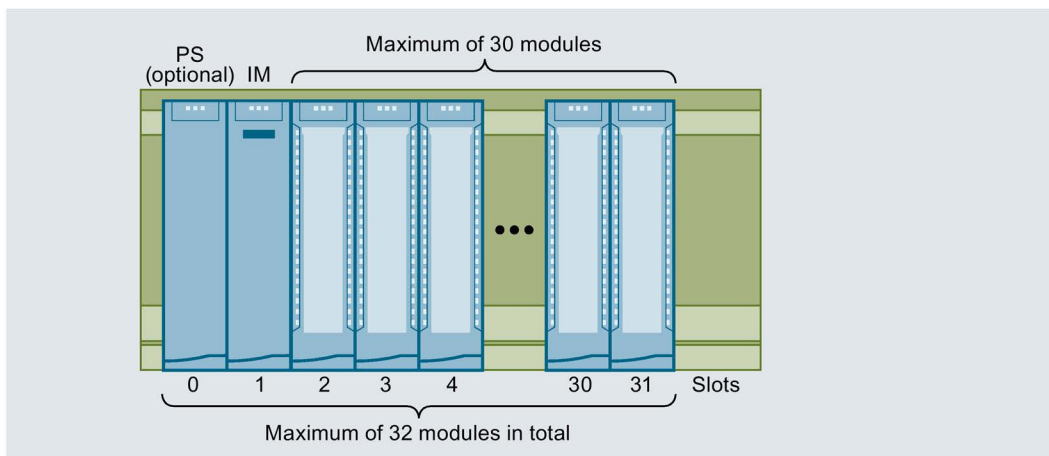

Maximum configuration of SIMATIC ET 200MP distributed I/O system

5.2 Mounting position and ambient conditions

The SIMATIC S7-1500 automation system and the ET 200MP distributed I/O system support horizontal and vertical mounting positions.

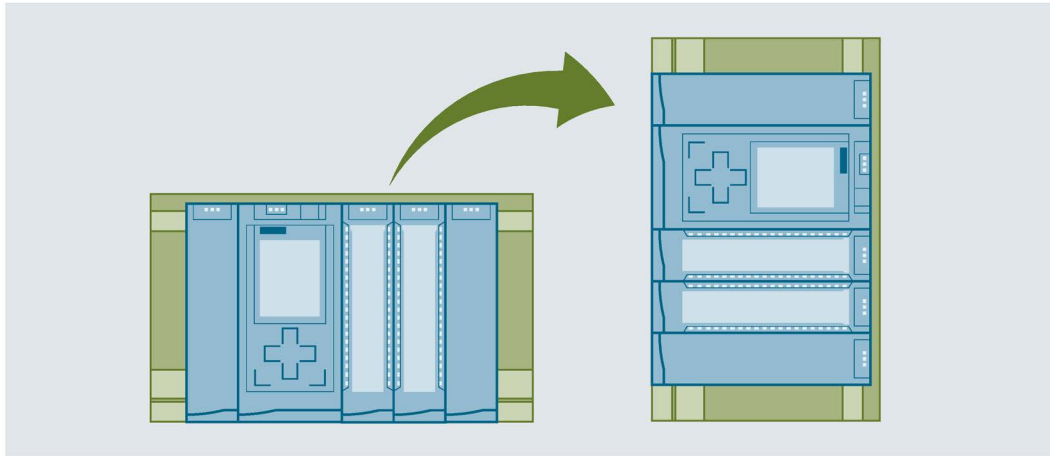

Horizontal/vertical mounting position using SIMATIC S7-1500 as an example

Ambient conditions SIMATIC S7-1500 and ET 200MP

The table below shows the permissible ambient conditions depending on the mounting position.

	Horizontal mounting position	Vertical mounting position
Permissible temperature range	0 °C to 60 °C	0 °C to 40 °C
Temperature change	10 K/h	10 K/h
Relative humidity	10% to 95%	10% to 95%

5.3 Minimum clearances

With the SIMATIC S7-1500 automation system, all modules can be mounted up to the outer edge of the mounting rail. Note the following minimum clearances:

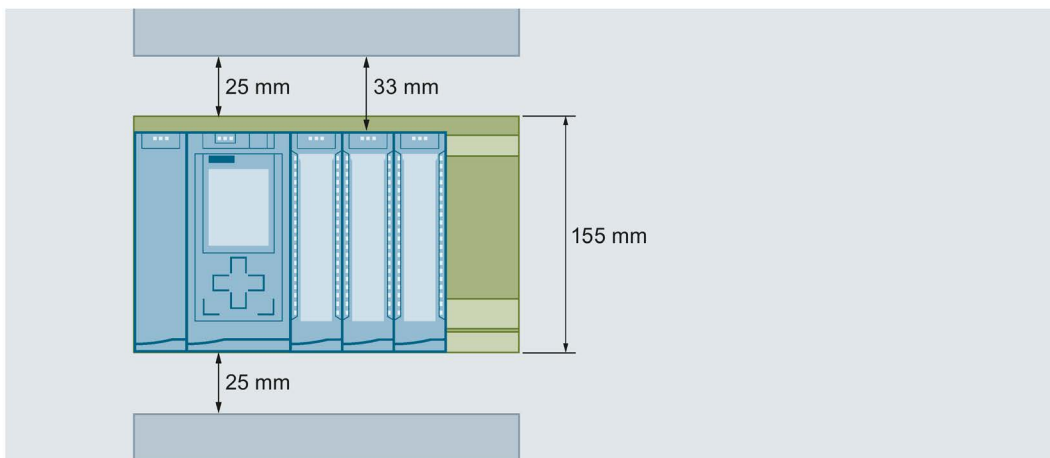

Minimum clearances in the control cabinet

6 Mounting rail

The figure below shows the SIMATIC S7-1500 mounting rail.

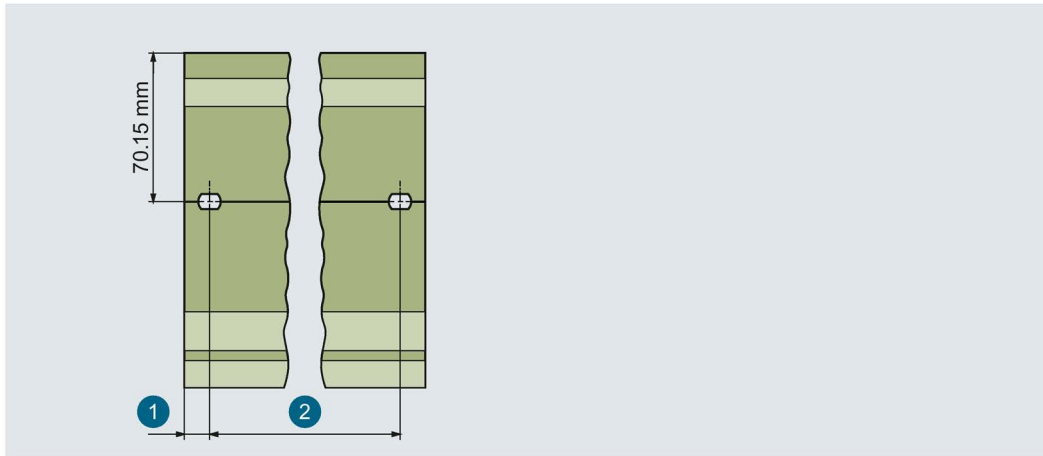

- ① Distance from edge
- ② Hole spacing

Hole spacing and distance from edge for SIMATIC S7-1500 mounting rail

Dimensions of SIMATIC S7-1500 mounting rails

The table below shows the dimensions of the available mounting rails and their article numbers.

Length of the mounting rail	Distance from edge	Hole spacing	Article number
	①	②	
160 mm	10 mm	140 mm	6ES7590-1AB60-0AA0
245 mm	10 mm	225 mm	6ES7590-1AC40-0AA0
482.6 mm	8.3 mm	466 mm	6ES7590-1AE80-0AA0
530 mm	15 mm	500 mm	6ES7590-1AF30-0AA0
830 mm	15 mm	800 mm	6ES7590-1AJ30-0AA0
2000 mm (without drill holes)	15 mm	500 mm	6ES7590-1BC00-0AA0

7 Controller



SIMATIC S7-1500 controllers are characterized by maximum performance capability thanks to a high-performance backplane bus, very short terminal-to-terminal response time and extremely fast signal processing.

The controller (CPU) executes the user program. The integrated system power supply of the controller provides power to the modules used through the backplane bus.

A fail-safe version is available for each SIMATIC S7-1500 controller (except C-CPU). To use the safety functions in the TIA Portal, you need the "STEP 7 Safety Advanced" option package.

During commissioning of the plant you can, for example, change the IP address of the CPU directly via the display, thus saving time and costs. In the event of a service call, the plant downtimes are minimized by quick access to diagnostics alarms.

For effective commissioning and fast optimization of drives and controls, the SIMATIC S7-1500 supports extensive trace functions for all CPU tags.

A SIMATIC S7-1500 controller also offers additional functions:

- Communication via Ethernet/PROFINET
- Communication via PROFIBUS
- HMI communication
- Communication via OPC UA
- Web server, technology functions, system diagnostics, protection functions integrated
- When using an F-CPU: Safety mode

7.1 What can you do with the CPU?

SIMATIC S7-1500 provides you with a variety of CPUs that can be integrated. You can expand each CPU with I/O, communications and technology modules. If the memory and performance of a CPU 1511-1 PN, for example, are sufficient for you, simply expand this with communication modules for PROFIBUS and PROFINET. For technology functions, technology CPUs and technology modules are available in addition to compact CPUs.

The CPU provides you with the following options:

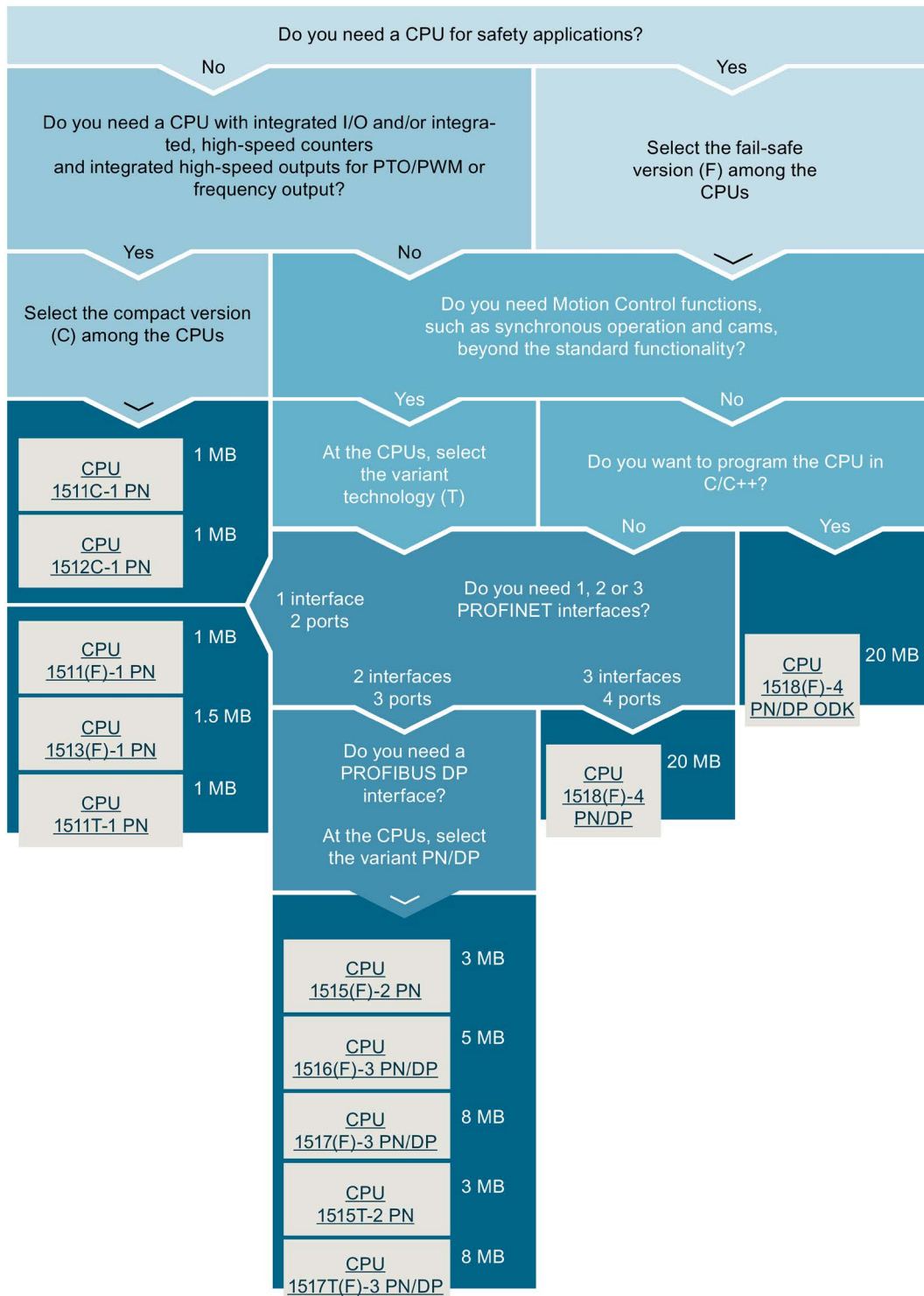

Selection guide for CPUs



7.2 Technical specifications of CPUs

Standard and F-CPU

CPU	1511-1 PN 1511F-1 PN 1511T-1 PN	1513-1 PN 1513F-1 PN	1515-2 PN 1515F-2 PN 1515T-2 PN	1516-3 PN/DP 1516F-3 PN/DP	1517-3 PN/DP 1517F-3 PN/DP 1517T-3 PN/DP 1517TF-3 PN/DP	1518-4 PN/DP 1518F-4 PN/DP 1518-4 PN/DP ODK 1518F-4 PN/DP ODK
Article number						
Standard CPU:	6ES7511-1AK01-0AB0	6ES7513-1AL01-0AB0	6ES7515-2AM01-0AB0	6ES7516-3AN01-0AB0	6ES7517-3AP00-0AB0	6ES7518-4AP00-0AB0
F-CPU	6ES7511-1FK01-0AB0	6ES7513-1FL01-0AB0	6ES7515-2FM01-0AB0	6ES7516-3FN01-0AB0	6ES7517-3FP00-0AB0	6ES7518-4FP00-0AB0
T-CPU	6ES7511-1TK01-0AB0	---	6ES7515-2TM01-0AB0	---	6ES7517-3TP00-0AB0	---
TF-CPU	---	---	---	---	6ES7 517-3UP00-0AB0	---
ODK-CPU	---	---	---	---	---	6ES7518-4AP00-3AB0
ODK F-CPU	---	---	---	---	---	6ES7 518-4FP00-3AB0
Manual						
Standard CPU:	↓	↓	↓	↓	↓	↓
T-CPU	↓	---	↓	---	↓	---
ODK-CPU	---	---	---	---	---	↓
F-CPU	↓	---	---	---	---	---
Supply voltage, permissible range of all the CPUs 19.2 V DC ... 28.8 V DC						
Code work memory						
Standard CPU:	150 KB	300 KB	500 KB	1 MB	2 MB	4 MB
T-CPU	225 KB	---	750 KB	---	3 MB	---
F-CPU	225 KB	450 KB	750 KB	1.5 MB	3 MB	6 MB
Data work memory	1 MB	1.5 MB	3 MB	5 MB	8 MB	20 MB
Processing times						
Bit operations	0.06 µs	0.04 µs	0.03 µs	0.01 µs	0.002 µs	0.001 µs
Word operations	0.072 µs	0.048 µs	0.036 µs	0.012 µs	0.003 µs	0.002 µs
Interfaces						
PROFINET IO	1	1	1	1	1	1
PROFINET	---	---	1	1	1	2
Number of PROFINET ports	2	2	3	3	3	4

CPU	1511-1 PN 1511F-1 PN 1511T-1 PN	1513-1 PN 1513F-1 PN	1515-2 PN 1515F-2 PN 1515T-2 PN	1516-3 PN/DP 1516F-3 PN/DP	1517-3 PN/DP 1517F-3 PN/DP 1517T-3 PN/DP 1517TF-3 PN/DP	1518-4 PN/DP 1518F-4 PN/DP 1518-4 PN/DP ODK 1518F-4 PN/DP ODK
PROFIBUS DP	---	---	---	1	1	1
Technology						
Motion Control resources	800	800	2400	2400	10240	10240
Isochronous mode	X	X	X	X	X	X
Web server	X	X	X	X	X	X

Compact CPUs

Controller	1511C-1 PN	1512C-1 PN
Article number	6ES7511-1CK00-0AB0	6ES7512-1CK00-0AB0
Manual		
Supply voltage, permissible range	19.2 V DC to 28.8 V DC	19.2 V DC to 28.8 V DC
Code work memory	175 KB	250 KB
Data work memory	1 MB	1 MB
Processing time for bit operations	60 ns	48 ns
PROFINET interfaces	1	1
Number of PROFINET ports	2	2
Integrated analog inputs/outputs	5 inputs/2 outputs	5 inputs/2 outputs
Integrated digital inputs/outputs	16 inputs/16 outputs	32 inputs/32 outputs
Technology		
Motion Control resources	800	800
Isochronous mode	X	X
High-speed counters	6	6
Pulse generators (pulse width modulation, Pulse Train Output, frequency output)	4 (PTOx/PWMx)	4 (PTOx/PWMx)
Web server	X	X

Code work memory: Volatile memory that contains runtime-relevant parts of the program code.

Data work memory: Volatile memory that contains the runtime-relevant parts of the data blocks and technology objects.

7.3 Safety

For fail-safe operation of your plant, program the F-CPU of the SIMATIC S7-1500. Use the "STEP 7 Safety Advanced" option package of the TIA Portal for this purpose. In combination with the TIA Portal, the F-CPU offers optimal integration of fail-safe systems; one controller, one communication system and one engineering platform for standard and fail-safe automation:

- Integration of safety technology
- Instructions approved by German Technical Inspectorate for frequently required safety applications
- Integration of safety functions up to SIL 3 according to IEC 62061 and/or PL e according to EN ISO 13849-1
- Uniform engineering for standard and safety automation
- Simple documentation of changes
- Support in the acceptance of the safety program and no renewed acceptance of the safety program after changes in the standard program

7.4 Security

Security means protection of technical systems against sabotage, espionage and human error.

Protection functions

To set up secure networks, the SIMATIC S7-1500 automation system offers an integrated security concept from authorization levels up to block protection:

Protection function	Description
Access protection	Protection against unauthorized configuration changes through four authorization levels and integrated firewall
Know-how protection	Protection against unauthorized access and modifications to algorithms by means of password protection
Copy protection	Protection against duplication of programs by linking individual blocks with the serial number of the original memory card on the SIMATIC memory card
Locking the CPU	Protection against unauthorized access by locking the front cover with a seal or a lock

You can find additional information about security mechanisms of the SIMATIC automation systems in the "Security" document at [SIMATIC S7 controllers](#).

Secure Communication

It is becoming increasingly necessary to transfer data to external computers in encrypted form via Intranet or public networks.

SIMATIC S7-1500 CPUs with firmware version 2.0 and higher support the Internet PKI (RFC 5280) with STEP 7 as of V14. This makes the configuration and the operation of Secure Communication possible, for example:

- Hypertext Transfer Protocol Secure (HTTPS)
- Secure Open User Communication
- Secure Communication with OPC UA

A public key infrastructure (PKI) can issue, distribute and check digital certificates. For S7-1500 CPUs, you create certificates for various applications in the CPU properties in STEP 7, for example: TLS certificates for Secure Open User Communication, Web server certificates, OPC UA certificates.

Communications processors with integrated security functions

For special requirements of your plant, use communications processors (Page 30) with integrated security functions such as access protection using a firewall, protection against data manipulation using VPN, FTPS, HTTPS, SNMPv3 and secure NTP.

7.5 Diagnostics

Integrated diagnostics across all levels of the automation is incorporated in the SIMATIC S7-1500 automation system. All SIMATIC products have integrated diagnostic functions which you can use to analyze and localize faults and errors efficiently. This reduces the commissioning periods required and minimizes standstill times in production.

A uniform display concept ensures that error messages in the TIA Portal, on the HMI, the Web server and in the display of the CPU are visualized identically as plain text information.

You can optionally configure machine and plant diagnostics, i.e. the logic of these process diagnostic messages or monitoring depends directly on the state of the plant and is defined by you.

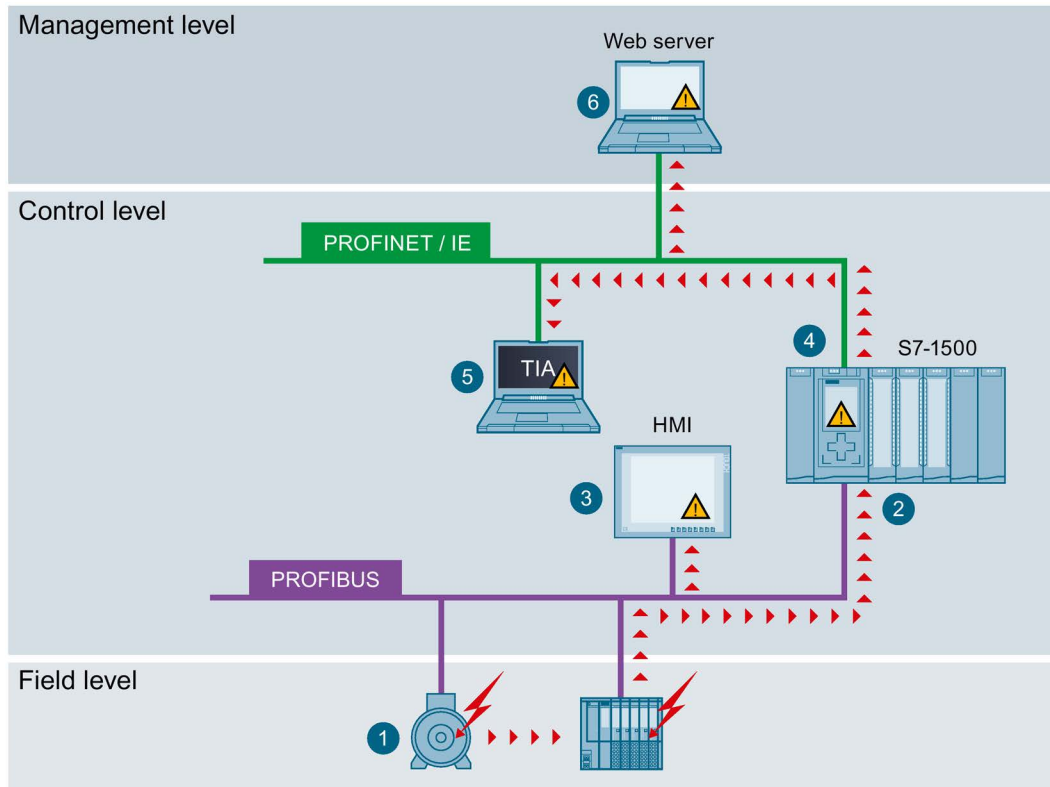

- 1 Monitoring functions are integrated in the hardware as standard.
- 2 Diagnostics is implemented system-wide across bus limits.
- 3 Output of the cause of the error in plain text, archiving and logging of alarms
- 4 Automatic localization of the error source
- 5 Configurability of alarms
- 6 Plant-wide, uniform display of system status



Display of diagnostic information

Faults in the plant are immediately detected and reported on the display devices, even in STOP mode. As a result, system diagnostics is always consistent with the actual state of the plant.

8 Interface modules for SIMATIC S7-1500 I/O devices

An interface module connects the SIMATIC S7-1500 I/O devices as ET 200MP distributed I/O system via PROFINET or PROFIBUS with the controller.

Interface modules

Short designation	IM 155-5 PN HF IM 155-5 PN ST	IM 155-5 DP ST
Article number		
High Feature (HF)	6ES7155-5AA00-0AC0	---
Standard (ST)	6ES7155-5AA00-0AB0	6ES7155-5BA00-0AB0
Manual		
High Feature (HF)		---
Standard (ST)		
Supply voltage	24 V DC	24 V DC
Number of IO modules	30	12
Interfaces	1 x PROFINET IO; integrated 2-port switch	1 x PROFIBUS
Min. slave interval	---	100 µs
Isochronous real-time communication (IRT)	X	---
Isochronous mode	X (shortest cycle 250 µs)	---
Prioritized startup	X	---
Device replacement without programming device	X (LLDP; address assignment by a tool, for example, the TIA Portal)	---
Shared device		
High Feature (HF)	4 IO controllers	---
Standard (ST)	2 IO controllers	---
Identification data	I&M 0 to 3	I&M 0 to 3
Media redundancy (MRP)	X	---
Media redundancy with planned duplication (MRPD)		
High Feature (HF)	X	---
Standard (ST)	---	---
System redundancy on S7-400H		
High Feature (HF)	With GSD file and STEP 7 V5.5 SP3 or higher	---
Standard (ST)	---	---
GSD file for ET 200MP	PROFINET	PROFIBUS

9 Inputs/outputs

The I/O modules form the interface between the controller and the process. The controller detects the current process state via the connected sensors and actuators, and triggers the corresponding reactions.



Digital and analog modules provide the inputs/outputs that are required for the respective task.

The input/output modules are divided into function classes.

Function classes of input/output modules

The table below shows selected properties and technical specifications of different function classes of input/output modules.

Function class		
High Speed (HS)	<ul style="list-style-type: none"> Special modules for extremely fast applications Shortest input delays Shortest conversion times Isochronous mode 	
High Feature (HF)	<ul style="list-style-type: none"> Flexible use Even for complex applications Parameters for each channel Diagnostics for each channel Add-on functions 	With analog modules <ul style="list-style-type: none"> Highest accuracy (<0.1%) High common mode voltage (e. g. 60 V DC / 30 V AC), if appropriate single-channel electrical isolation
Standard (ST)	<ul style="list-style-type: none"> Medium price range Parameter per load group / module Diagnostics per load group / module 	With analog modules <ul style="list-style-type: none"> Universal modules Accuracy = 0.3% Common-mode voltage approx. 10 V to 20 V
Basic (BA)	<ul style="list-style-type: none"> Inexpensive, simple modules No parameters No diagnostics 	

9.1 Which I/O devices are the correct ones?

SIMATIC S7-1500 offers a wide range of I/O modules. Depending on the complexity of your plant and the technical and functional requirements, you perform your planning flexibly and in a modular manner with SIMATIC components.

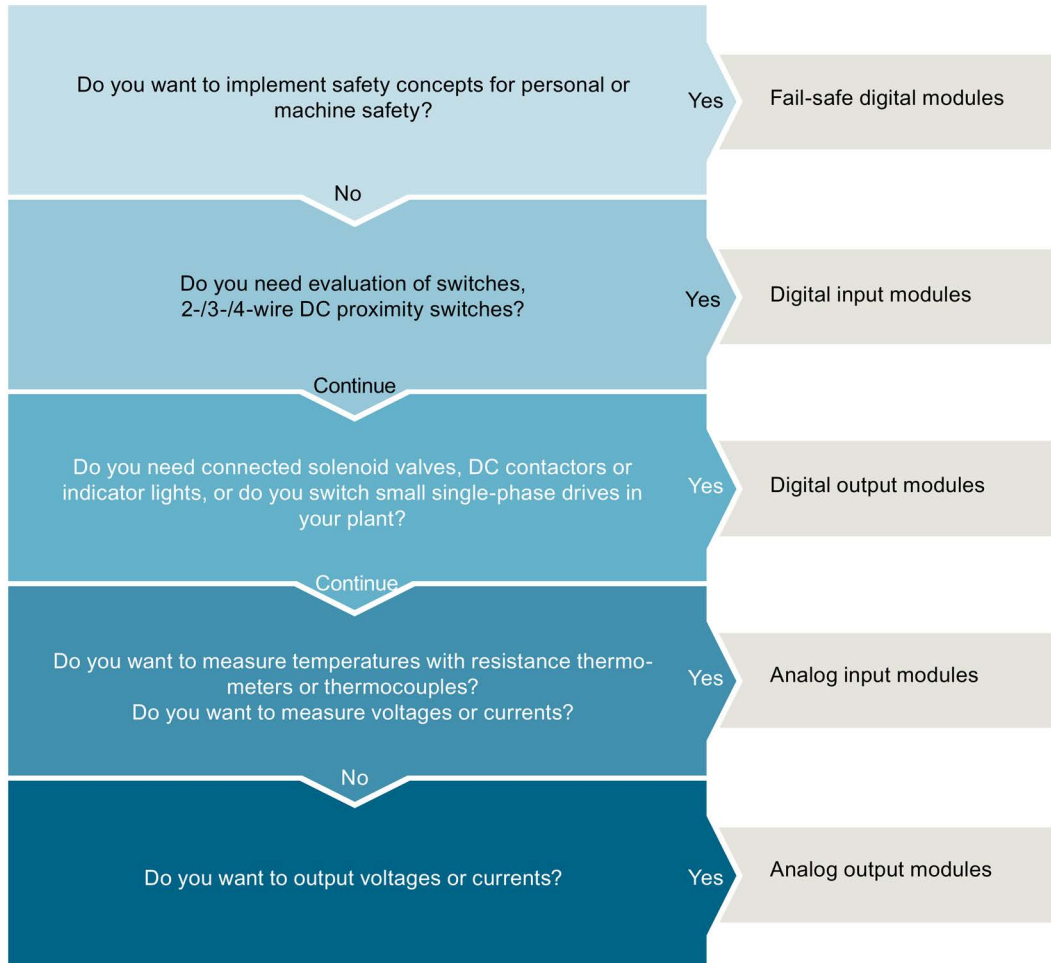

Selection guide for input/output modules

9.2 Digital input modules

Digital input modules and digital input/output module





Short designation	DI 16x24VDC HF DI 16x24VDC BA	DI 32x24V DC HF DI 32x24V DC BA	DI 16x 24VDC SRC BA	DI 16x24... 125VUC HF	DI 16x 230VAC BA	DI 16x24V DC / DQ 16x24V/0.5A BA
Article number						
High Feature (HF)	6ES7521-1BH00-0AB0	6ES7521-1BL00-0AB0	---	6ES7521-7EH00-0AB0	---	---
Basic (BA)	6ES7521-1BH10-0AA0	6ES7521-1BL10-0AA0	6ES7521-1BH50-0AA0	---	6ES7521-1FH00-0AA0	6ES7523-1BL00-0AA0
Manual						
High Feature (HF)			---		---	---
Basic (BA)				---		
Width						
High Feature (HF)	35 mm	35 mm	---	35 mm	---	---
Basic (BA)	25 mm	25 mm	35 mm	---	35 mm	25 mm
Number of inputs	16	32	16	16	16	16
Electrical isolation between channels	---	X	---	X	X	---
Number of potential groups	1	2	1	1	4	1
Rated input voltage	24 V DC	24 V DC	24 V DC	24 V UC to 125 V UC	120/230 V AC	24 V DC
Diagnostic interrupt	Only with HF	Only with HF	---	X	---	---
Hardware interrupt	Only with HF	Only with HF	---	X	---	---
Isochronous mode	Only with HF	Only with HF	---	---	---	---
Input delay						
High Feature (HF)	0.05 ms to 20 ms (configurable)		---	0.05 ms to 20 ms (configurable with DC) 20 ms (fixed at AC)	---	---
Basic (BA)	Typ. 3 ms (fixed)	Typ. 3 ms (fixed)	Typ. 3 ms (fixed)	---	Typ. 25 ms (fixed)	Typ. 3 ms (fixed)
Integrated counting functions (Two channels can optionally be used as counter with 1 kHz)	Only with HF: Counting up to 1 kHz	Only with HF: Counting up to 1 kHz	---	---	---	---

9.3 Digital output modules

Digital output modules and digital input/output module (DC)







Short designation	DQ 8x24VDC/2A HF	DQ 32x24VDC/ 0.5A HF DQ 32x24VDC/ 0.5A BA	DQ 16x24VDC/ 0.5A HF DQ 16x24VDC/ 0.5A BA	DI 16x24VDC / DQ16x24V/0.5A BA
Article number				
High Feature (HF)	6ES7522-1BF00-0AB0	6ES7522-1BL01-0AB0	6ES7522-1BH01-0AB0	---
Basic (BA)	---	6ES7522-1BL10-0AA0	6ES7522-1BH10-0AA0	6ES7523-1BL00-0AA0
Manual				
High Feature (HF)				---
Basic (BA)	---			
Width				
High Feature (HF)	35 mm	35 mm	35 mm	---
Basic (BA)	---	25 mm	25 mm	25 mm
Number of outputs	8	32	16	16
Type	Transistor	Transistor	Transistor	Transistor
Electrical isolation between channels	X	Only with BA	Only with BA	X
Number of potential groups	2	4; only with BA	2; only with BA	2
Rated output voltage	24 V DC	24 V DC	24 V DC	24 V DC
Rated output current	2 A	0.5 A	0.5 A	0.5 A
Diagnostic interrupt	X	Only with HF	Only with HF	---
Hardware interrupt	---	---	---	---
Isochronous mode	---	Only with HF	Only with HF	---
Pulse-width modulation (PWM)	X	---	---	---

Digital output modules (UC, AC)

Short designation	DQ 16x24 ... 48VUC/125V DC/0.5A ST	DQ 8x230VAC /5A ST relay	DQ 16x230VAC/2A ST relay	DQ 8x230VAC/ 2A ST Triac	DQ 16x230V AC/1A ST Triac
Article number	6ES7522-5EH00-0AB0	6ES7522-5HF00-0AB0	6ES7522-5HH00-0AB0	6ES7522-5FF00-0AB0	6ES7522-5FH00-0AB0
Manual					
Width	35 mm	35 mm	35 mm	35 mm	35 mm
Number of outputs	16	8	16	8	16
Type	Transistor	Relay	Relay	Triac	Triac
Electrical isolation between channels	X	X	X	X	X
Number of potential groups	1	16	8	8	8
Relay coil supply voltage	---	24 V DC	24 V DC	---	---
Rated output voltage	24 V DC to 125 V DC / 24 V AC to 48 V AC	24 V DC to 120 V DC / 24 V AC to 230 V AC	24 V DC to 120 V DC / 24 V AC to 230 V AC	230 V AC	230 V AC
Rated output current	0.5 A	5 A	2 A	2 A	1 A
Diagnostic interrupt	---	X	X	---	---
Hardware interrupt	---	---	---	---	---

9.4 Analog input modules





Analog input modules and analog input/output module

Short designation	AI 8xU/I HF AI 8xU/I HS	AI 8xU/R/RTD/TC HF AI 8xU/I/RTD/TC ST	AI 4xU/I/RTD/TC ST	AI 4xU/I/RTD/TC/ AQ 2xU/I ST
Article number				
High Feature (HF)	6ES7531-7NF00-0AB0	6ES7531-7PF00-0AB0	---	---
High Speed (HS)	6ES7531-7NF10-0AB0	---	---	---
Standard (ST)	---	6ES7531-7KF00-0AB0	6ES7531-7QD00-0AB0	6ES7534-7QE00-0AB0
Manual				
High Feature (HF)			---	---
High Speed (HS)		---	---	---
Standard (ST)	---			
Width	35 mm	35 mm	25 mm	25 mm
Number of inputs	8	8	4	4

Short designation	AI 8xU/I HF AI 8xU/I HS	AI 8xU/R/RTD/TC HF AI 8xU//RTD/TC ST	AI 4xU/I/RTD/TC ST	AI 4xU/I/RTD/TC/ AQ 2xU/I ST
Resolution	16 bits including sign	16 bits including sign	16 bits including sign	16 bits including sign
Measurement type	Voltage, current	Voltage, current, resistance, thermal resistor, thermocouple	Voltage, current, resistance, resistance thermometer, thermocouple	Voltage, current, resistance, thermal resistor, thermocouple
Electrical isolation between channels	Only with HF	Only with HF	---	---
Number of potential groups	1	1	---	---
Rated supply voltage	24 V DC	24 V DC	24 V DC	24 V DC
Permissible potential difference between inputs (UCM)	HF: 60 V DC / 30 V AC HS: 10 V DC	HF: 60 V DC / 30 V AC ST: 10 V DC	20 V DC	20 V DC
Diagnostic interrupt	X	X	X	X
Hardware interrupt	X Two high limits and two low limits in each case	X Two high limits and two low limits in each case	X Two high limits and two low limits in each case	X Two high limits and two low limits in each case
Isochronous mode	Only HS	---	---	---
Conversion time (per channel)	HF: Fast mode: 4/18/22/102 ms; Standard mode: 9/52/62/302 ms HS: 62.5 µs, per module, regardless of number of activated channels	HF: Fast mode: 4/18/22/102 ms; Standard mode: 9/52/62/302 ms ST: 9/23/27/107 ms	9/23/27/107 ms	9/23/27/107 ms
Calibration in RUN mode	Only with HF	Only with HF	X	X
Oversampling	Only with HS	---	---	---
Scale measuring range	Only with HF	---	---	---
Scale temperatures	---	Only with HF	---	---
Scale measured values	Only with HF	---	---	---

9.5 Analog output modules

Analog output modules and analog input/output module



Short designation	AQ 8xU/I HS	AQ 4xU/I HF AQ 4xU/I ST	AQ 2xU/I ST	AI 4xU/I/RTD/TC/ AQ 2xU/I ST
Article number				
High Feature (HF)	---	6ES7532-5ND00-0AB0	---	---
High Speed (HS)	6ES7532-5HF00-0AB0	---	---	---
Standard (ST)	---	6ES7532-5HD00-0AB0	6ES7532-5NB00-0AB0	6ES7534-7QE00-0AB0
Manual				
High Feature (HF)	---		---	---
High Speed (HS)		---	---	---
Standard (ST)	---			
Width				
	35 mm	35 mm	25 mm	25 mm
Number of outputs	8	4	2	2
Resolution	16 bits including sign	16 bits including sign	16 bits including sign	16 bits including sign
Output type	Voltage/current	Voltage/current	Voltage/current	Voltage/current
Electrical isolation between channels	---	Only with HF	---	---
Number of potential groups	---	1	---	---
Rated supply voltage	24 V DC	24 V DC	24 V DC	24 V DC
Diagnostic interrupt	X	X	X	X
Isochronous mode	X	Only with HF	---	---
Conversion time (per channel)	50 μ s, regardless of number of activated channels	HF: 125 μ s, regardless of number of activated channels ST: 0.5 ms	0.5 ms	0.5 ms
Calibration in RUN mode	X	Only with ST	X	X
Oversampling	X	---	---	---

9.6 Fail-safe digital modules

Fail-safe digital modules are available for implementing safety concepts in the area of equipment and personnel safety (for example, for emergency stop devices in the operation of processing machines).

The fail-safe modules ensure safe processing of field information (sensors: e.g., emergency stop buttons, light barriers; actuators, e.g. motor control). You are provided with all the hardware and software components required for safe processing, according to the required safety class. The following table shows the available fail-safe modules.

Fail-safe digital modules

Short designation	F-DI 16x 24VDC PROFI-safe	F-DQ 8x24VDC/2A PPM
Article number	6ES7526-1BH00-0AB0	6ES7526-2BF00-0AB0
Manual		
Width	35 mm	35 mm
Number of inputs	16	---
Number of outputs	---	8
Type output	---	Transistor
Electrical isolation between channels	---	---
Rated input voltage	24 V DC	---
Rated output voltage	---	24 V DC
Rated output current	---	2 A
Maximum achievable safety class in safety mode	PLe/SIL 3	PLe/SIL 3
Low demand mode: PFD according to SIL3	< 5.00E-05	< 6.00E-05
High demand/continuous mode: PFH according to SIL3	< 1.00E-09 1/h	< 2.00E-09 1/h
Diagnostic interrupt	X	X
Hardware interrupt	---	---
Input delay	0.4 ms to 20 ms (configurable by channel)	---

10 Communication

10.1 Integrated interfaces for communication

Interfaces for communication via PROFINET and PROFIBUS DP (as of CPU 1516) are already integrated in the CPUs. Additional communication modules enhance the communication capabilities of the SIMATIC S7-1500 with additional functions or interfaces. For your automation task you have the following communication options available via the individual interfaces:



Communication options	PN/IE	DP	Serial
PG communication for commissioning, testing, diagnostics	X	X	---
HMI communication for operator control and monitoring	X	X	---
Data exchange with TCP/IP, UDP, ISO-on-TCP, ISO protocol	X	---	---
As OPC UA server data exchange with OPC UA clients	X	---	---
Communication via Modbus TCP	X	---	---
Communication via UDP Multicast	X	---	---
Sending process alarms via e-mail	X	---	---
File management and file access via FTP (File Transfer Protocol); CP may be the FTP client and FTP server	X	---	---
S7 communication	X	X	---
Serial point-to-point or multi-point connection Data exchange via point-to-point with Freeport, 3964 (R), USS or Modbus protocol	---	---	X
Web server Data exchange via HTTP(S), for example for diagnostics	X	---	---
SNMP (Simple Network Management Protocol)	X	---	---
Time synchronization	X	X	---

10.2 Communication modules/processors



For special requirements of your plant, use communications processors (CPs) for security functions to secure Industrial Ethernet networks.

If your system requires additional interfaces, communication modules (CM) expand your S7-1500 CPU with other interfaces of an interface type such as PROFINET, PROFIBUS or point-to-point connection. The CMs for point-to-point connection allow, for example, Freeport or Modbus communication via their RS232, RS422 and RS485 interfaces.





Communication modules for PROFINET and Industrial Ethernet

Short designation	CM 1542-1	CP 1543-1
Article number	6GK7 542-1AX00-0XE0	6GK7543-1AX00-0XE0
Manual		
Bus system	PROFINET	Industrial Ethernet
Interface	RJ45	RJ45
Data transmission rate	10/100 Mbps	10/100/1000 Mbps
Functionality and protocols	TCP/IP, ISO-on-TCP, UDP, Modbus TCP, S7 communication, IP Broadcast/Multicast, IP routing, SNMPv1	TCP/IP, ISO, UDP, Modbus TCP, S7 communication, IP Broadcast/Multicast, Security, Secure Open User Communication, SMTPS, diagnostics SNMPv1/v3, DHCP, FTP client/server e-mail, IPV4/IPV6
Diagnostic interrupt	X	X
Hardware interrupt	X	---
Isochronous mode	---	---

Communication modules for PROFIBUS

Short designation	CM 1542-5	CP 1542-5
Article number	6GK7542-5DX00-0XE0	6GK7542-5FX00-0XE0
Manual		
Bus system	PROFIBUS	PROFIBUS
Interface	RS485	RS485
Data transmission rate	9600 bps to 12 Mbps	9600 bps to 12 Mbps
Functionality and protocols	DPV1 master/slave, S7 communication, PG/OP communication, Open User Communication	DPV1 master/slave, S7 communication, PG/OP communication, FDL
Diagnostic interrupt	X	X
Hardware interrupt	X	X
Isochronous mode	---	---

Communication modules for point-to-point connection

Short designation	CM PtP RS232 HF CM PtP RS232 BA	CM PtP RS422/485 HF CM PtP RS422/485 BA
Article number		
High Feature (HF)	6ES7541-1AD00-0AB0	6ES7541-1AB00-0AB0
Basic (BA)	6ES7540-1AD00-0AA0	6ES7540-1AB00-0AA0
Manual		
High Feature (HF)		
Basic (BA)		
Interface	RS232	RS422/485
Data transmission rate		
High Feature (HF)	300 to 115 200 bps	300 to 115 200 bps
Basic (BA)	300 to 19 200 bps	300 to 19 200 bps
Frame length, max.		
High Feature (HF)	4 KB	4 KB
Basic (BA)	1 KB	1 KB
Diagnostic interrupt	X	X
Hardware interrupt	---	---
Isochronous mode	---	---
Protocols		
High Feature (HF)	Freeport, 3964 (R), Modbus RTU master, Modbus RTU slave	Freeport, 3964 (R), Modbus RTU master, Modbus RTU slave
Basic (BA)	Freeport, 3964 (R)	Freeport, 3964 (R)

10.3 Safety-related communication via fail-safe modules

The figure below provides an overview of the possibilities of safety-related communication via PROFINET IO in SIMATIC Safety fail-safe systems with S7-1500 F-CPU.

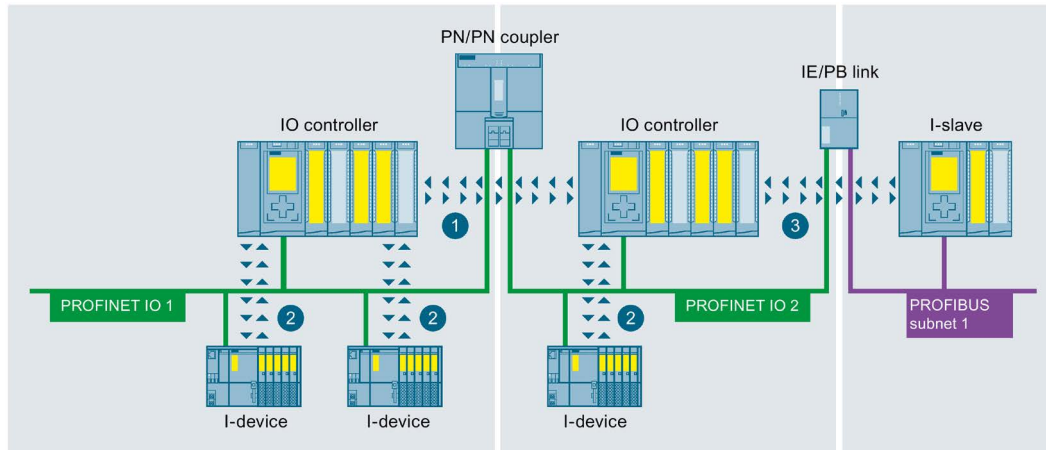

- 1 Safety-related IO controller - IO controller communication
- 2 Safety-related IO controller - I-device communication
- 3 Safety-related IO controller - I-slave communication

Example of safety-related communication

11 Technology functions

11.1 Motion control

You use the integrated Motion Control functionality of SIMATIC S7-1500 for positioning and moving axes. Depending on the CPU (Page 15), the SIMATIC S7-1500 automation system supports different configuration limits for Motion Control technology objects.

With Motion Control instructions according to PLCopen, you control PROFIdrive-capable drives and drives with analog setpoint interface.

Motion Control technology objects

The table below shows the technology objects that are supported by the SIMATIC S7-1500 and S7-1500T. They occupy Motion Control resources in the CPU. Cams do not occupy resources in the CPU.

Technology objects	SIMATIC S7-1500	SIMATIC S7-1500T	Resource requirements per technology object
Speed-controlled axis	X	X	40 per speed-controlled axis
Positioning axis	X	X	80 per positioning axis
Synchronous axis	X	X	160 per synchronous axis
External encoder	X	X	80 per external encoder
Measuring input	X	X	40 per measuring input
Output cam	X	X	20 per output cam
Cam track	X	X	160 per cam track
Cams	---	CPU 1511T-1 PN: Max. 20 CPU 1515T-2 PN: Max. 60 CPU 1517T/F-3 PN/DP: Max. 128	---

Motion Control technology functions

The table below shows the technology functions offered by both SIMATIC S7-1500 and S7-1500T and the extended Motion Control functions of the technology CPUs.

Technology functions	SIMATIC S7-1500	SIMATIC S7-1500T
Enable/disable axis	X	X
Acknowledge error/reinitialize	X	X
Move axis at set velocity	X	X
Move axis in jog mode	X	X
Pause axis	X	X
Home axis (absolute and on the fly)	X	X
Set position	X	X
Position axis relatively	X	X
Position axis absolutely	X	X
Position axis superimposed to active movement	X	X
Link axes to each other in gearing	X	X
Activate/deactivate output cam/cam track	X	X
Up to 4 encoders at positioning axis/following axis	---	X
Actual value coupling: Actual value as leading value (e.g. external encoder) can be specified for synchronous operation	---	X
Gearing with specification of the synchronous positions of leading and following axis	---	X
Camming	---	X
Synchronization in advance using leading value distance at gearing and camming	---	X

Motion Control configuration example

The SINAMICS Startdrive engineering tool is available in the TIA Portal for easy commissioning and optimization of SINAMICS drives. SINAMICS Startdrive enables efficient commissioning by means of the integrated axis control panel and extensive diagnostic functions.

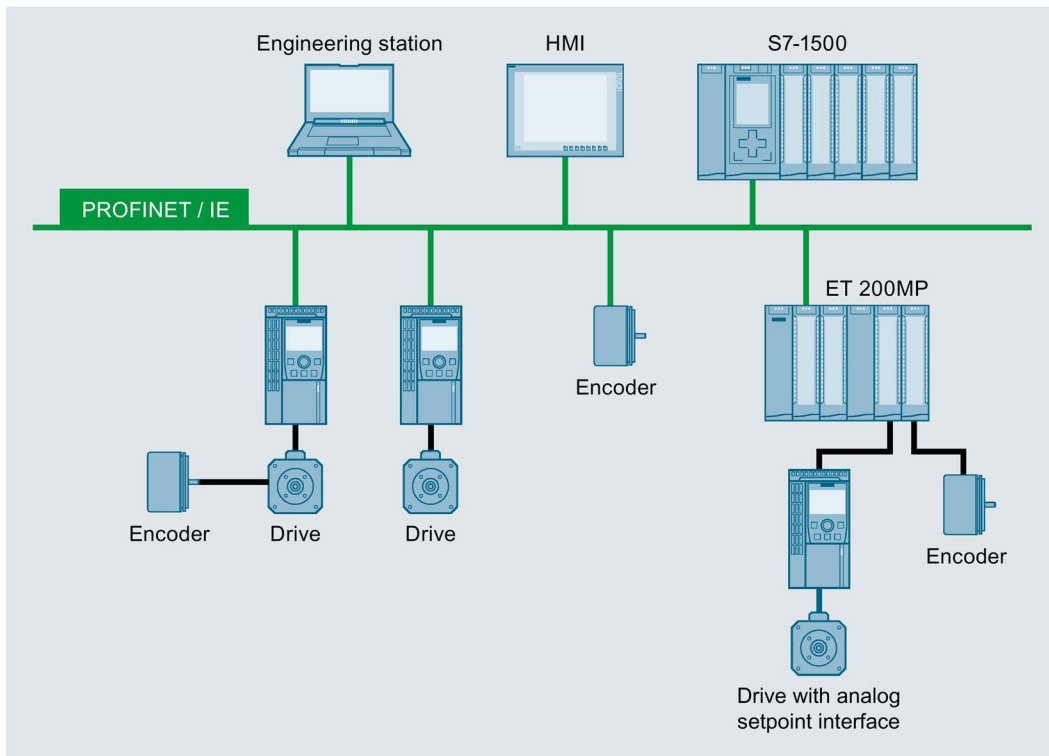

Example of a Motion Control configuration

11.2 Other technology functions

11.2.1 PID Control

PID compact controllers are integrated as standard in all S7-1500 CPUs. In your plant, the PID controller adjusts a physical setpoint and stabilizes it against interferences at the same time. Depending on your plant, you can use different PID controllers. All controllers support the following functions:

- Manageable configuration screens
- Automatic determination of the controller parameters
- Commissioning screens with integrated trace

PID controller versions

PID controllers	Description
PID Compact	Continuous PID controller
PID 3step	Step controller for integrating actuators
PID Temp	Temperature controller for heating and cooling with two separate actuators

11.2.2 Technology functions of the compact CPUs



Technology functions are integrated into the SIMATIC S7-1500 compact CPUs.

Function	Value	Description
Six high-speed counters	Up to 100 kHz	For pulse and incremental encoders
Frequency measurement	0.04 Hz - 400 kHz	
Period duration measurement	2.5 μ s - 25 s	
Velocity measurement		Dependent on measurement interval and signal evaluation Unit can be defined by user
Pulse width modulation (PWM output)	Max. 4	Output of a signal with defined period duration and variable on-load factor at DQ
Pulse Train Output (PTO output)	Max. 4	Output of position information, e. g. for activation of stepper motor drives or simulation of an incremental encoder
Frequency output	Up to 100 kHz	Precise assignment of a frequency value with high frequencies

11.3 Technology modules

11.3.1 Technology modules for counting, measuring and position detection

For technological tasks, powerful technology modules are available that perform these tasks largely autonomously and reduce the load on the CPU. The table below shows the available technology modules for counting, measuring and position detection.

Short designation	TM Count 2x24V	TM PosInput 2
Article number	6ES7550-1AA00-0AB0	6ES7551-1AB00-0AB0
Manual		
Connectable encoders	Incremental encoders for signals, 24 V, asymmetric, Pulse encoders with/without direction signal, Pulse encoders up/down	Incremental encoders for signals to RS-422 (5 V differential signal), Pulse encoders with/without direction signal, Pulse encoders up/down, Absolute encoders (SSI)
Max. count frequency	200 kHz: 800 kHz with pulse quadruplication	1 MHz 4 MHz with pulse quadruplication
Integrated DI	3 DIs per counter channel for <ul style="list-style-type: none"> • Start • Stop • Capture • Synchronization 	2 DIs per counter channel for <ul style="list-style-type: none"> • Start • Stop • Capture • Synchronization
Integrated DQ	2 DQs for comparators and limit values	2 DQs for comparators and limit values
Counting functions	Comparator Adjustable counting range, Incremental position detection	Comparator Adjustable counting range, Incremental and absolute position detection
Measuring functions	Frequency Period duration Velocity	Frequency Period duration Velocity
Diagnostic interrupt	X	X
Hardware interrupt	X	X
Isochronous mode	X	X

11.3.2 Technology module for time-based IO

Extremely high requirements on precision and speed can be met with time-based IO modules - regardless of the performance of the controller and the fieldbus. Time-based IO modules ensure that signals are output with a precisely defined response time. The I/O signals are processed on a time basis.

The table below shows the main features of the technology module for time-based IO. In conjunction with the "Output cam" and "Cam track" technology objects, the TM Timer DIDQ 16x24V ensures highly accurate cam output. In conjunction with the "Measuring input" technology object, the TM Timer DIDQ 16x24V ensures highly accurate detection of passing products.

Short designation	TM Timer DIDQ 16x24V
Article number	6ES7552-1AA00-0AB0
Manual	
Connectable encoders	24 V incremental encoder with signals A and B 24 V pulse encoder with a signal
Max. count frequency	200 kHz with quadruple evaluation
Integrated DI	Up to 8 DIs with the following functions: <ul style="list-style-type: none"> • Up to 2 time stamps per cycle (resolution 1 µs) • 32x oversampling • Counting function up to 50 kHz • Incremental encoder acquisition with 2 phase-shifted tracks • Configurable input filter to suppress interference
Integrated DQ	Up to 16 DQs with the following functions: <ul style="list-style-type: none"> • Up to 2 time stamps per cycle (resolution 1 µs) • 32x oversampling • Pulse-width modulated output • Configurable substitute values per DQ
Diagnostic interrupt	X
Hardware interrupt	---
Isochronous mode	X (required for the time stamp and oversampling functions)

11.3.3 Technology module for weighing technology

The technology modules SIWAREX WP521 and SIWAREX WP522 are used for the acquisition and processing of signals from weighing or force transducers. You can connect one scale (WP521) or two separate scales (WP522) respectively to the modules. The SIWAREX modules offer high accuracy.

The table below shows the main features of the technology modules for weighing technology.

Short designation	TM electronic weighing system SIWAREX WP 521 ST	TM electronic weighing system SIWAREX WP 522 ST
Article number	7MH4 980-1AA01	7MH4 980-2AA01
Manual		
Weighing channel	1 channel	2 channels
Interfaces	RS 485 with Modbus RTU or for connecting the remote display (per channel) Ethernet interface with SIWATOOL protocol and Modbus TCP/IP (1 for both channels)	
Integrated digital inputs	DI 3x24VDC	
Integrated digital outputs	DQ 4x24VDC	
Load cell connection	DMS load cells in 6- or 4-wire technology (per channel), 1 to 4 mV/V	
Functions	<ul style="list-style-type: none"> • Adjust the scale with weights or automatically • 3 limits • Tare • Set to zero • Trace • Commission with SIWATOOL (service tool for PC) 	
Diagnostic interrupt	---	
Hardware interrupt	X (configurable)	

12 Power supply

The power supply of an automation system to be dimensioned according to plant size. The SIMATIC S7-1500 CPUs are supplied via a load power supply. A system power supply that supplies the backplane bus is integrated in the CPUs. Depending on the system configuration, you can expand the integrated system power supply with up to two additional system power supply modules. If your plant has high power requirements (e.g. I/O load groups), you can connect additional load power supplies.

The main differences between the two power supplies for the SIMATIC S7-1500 automation system are listed below:

Power supply	Description
Load power supply (PM)	Supplies the S7-1500 system components such as CPU, system power supply (PS), input/output circuits of the I/O modules and any sensors and actuators with 24 V DC. You can install the load power supply directly to the left of the CPU (without connection to the backplane bus). The supply of the CPU or of the interface module with 24 V DC is optional if you supply the voltage for the backplane bus via a system power supply.
System power supply (PS)	Supplies only internally required system voltage. Supplies parts of the module electronics and the LEDs.

Configuration example of a system with load power supply and system power supply

The following figure shows a system configuration with load power supply and additional system power supply.

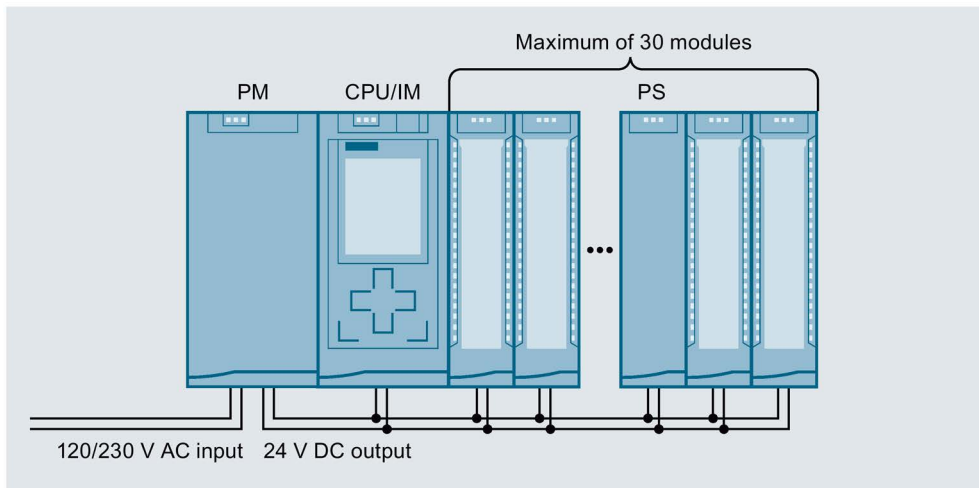



Overall configuration of power supply

In order to ensure the supply of the modules from the backplane bus, the incoming power is compared with the required power in the TIA Portal engineering system or in the TIA Selection Tool.

As early as in the planning stages, make sure that the power fed into the backplane bus is always greater than or equivalent to the power drawn.



System power supply modules

System power supplies supply the internal electronics of the S7-1500 modules with power via the backplane bus. The table below shows the available system power supply modules:

Short designation	PS 25W 24V DC	PS 60W 24/48/60V DC	PS 60W 120/230V AC/DC
Article number	6ES7505-0KA00-0AB0	6ES7505-0RA00-0AB0	6ES7507-0RA00-0AB0
Manual			
Rated input voltage	24 V DC	24 V DC, 48 V DC, 60 V DC	120 V AC, 230 V AC 120 V DC, 230 V DC
Output power	25 W	60 W	60 W
Electrical isolation from the backplane bus	X	X	X
Diagnostic interrupt	X	X	X

Load power supply modules

The load power supply modules with automatic range selection of the input voltage are optimally adapted in design and functionality to the SIMATIC S7-1500 controller. The table below shows the available load power supply modules:

Short designation	PM 70W 120/230V AC	PM 190W 120/230V AC
Article number	6EP1332-4BA00	6EP1333-4BA00
Manual		
Rated input voltage	120/230 V AC with automatic switchover	120/230 V AC with automatic switchover
Output voltage	24 V DC	24 V DC
Rated output current*	3 A	8 A
Power consumption	84 W	213 W

* Power increase by parallel connection of two equal load current supply modules possible

Using a SITOP power supply as an alternative to a load power supply

Alternatively, an external 24 V power supply from the [SITOP range](#) (SITOP smart or SITOP modular) can be used:

- For higher output currents and 1-phase or 3-phase infeed
- With redundant installation of the 24 V power supply as protection against failure of a power pack
- With buffering of the 24 V power supply (e. g. with DC UPS) as protection against power failure
- With selective monitoring of 24 V loads against overload or short-circuit

13 Connection elements and system cabling

Front connector and shield contact

The front connectors are used to wire the I/O modules. For modules with EMC-critical signals, such as analog modules and technology modules, the front connectors also need a shield contact.

The front connectors are available for 35 mm modules optionally with screw terminals and push-in terminals and for 25 mm modules with push-in terminals. The front connectors for 25 mm modules are included in the scope of delivery of the I/O modules.

24 V DC is supplied, for example, via a plug-in infeed element for analog modules.

The shield contact consists of shield bracket and shield terminal. Together with the shield terminal, the shield bracket allows the low-impedance, module-level connection of cable shields with minimum installation times. The shielding takes place without tools.

The components (infeed element, shielding bracket and shield clamp) are included in the scope of delivery of the modules.

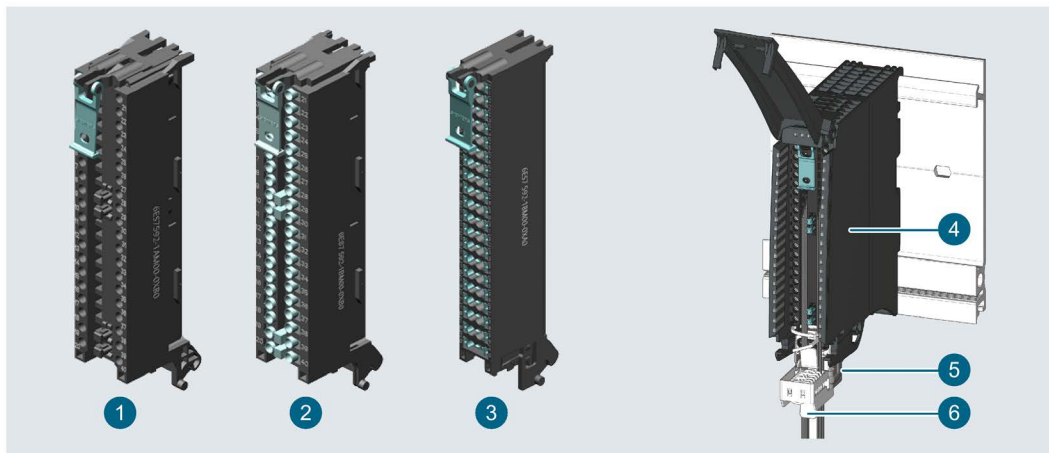

- 1 Front connector 35 mm with screw terminals
- 2 Front connector 35 mm with push-in terminals
- 3 Front connector 25 mm with push-in terminals
- 4 Front connector
- 5 Shield bracket
- 6 Shield terminal

Versions of the front connector with and without shield

U connector

The individual modules are connected to one another with the U connector. The U connector establishes the mechanical and electrical connection between the modules. The U connectors are included in the scope of delivery of the I/O modules.

System cabling SIMATIC TOP connect



Example: System cabling with SIMATIC TOP connect

For 35 mm modules, the system cabling SIMATIC TOP connect with prefabricated connection elements is available in two versions:

- Fully modular connection consisting of front connector module, connection cables and connection modules for connecting sensors and actuators from the field
- Flexible connection, consisting of front connector with single cores for wiring within the cabinet

You can find more information in the [SIMATIC TOP connect for S7-1500 and ET200MP](#) manual.

14 Software

14.1 TIA Portal

The SIMATIC controllers are integrated into the Totally Integrated Automation Portal. Engineering with the TIA Portal offers configuration and programming, common data storage and a uniform operating concept for control, visualization and drives.

The TIA Portal simplifies the integrated engineering in all configuration phases of a plant.

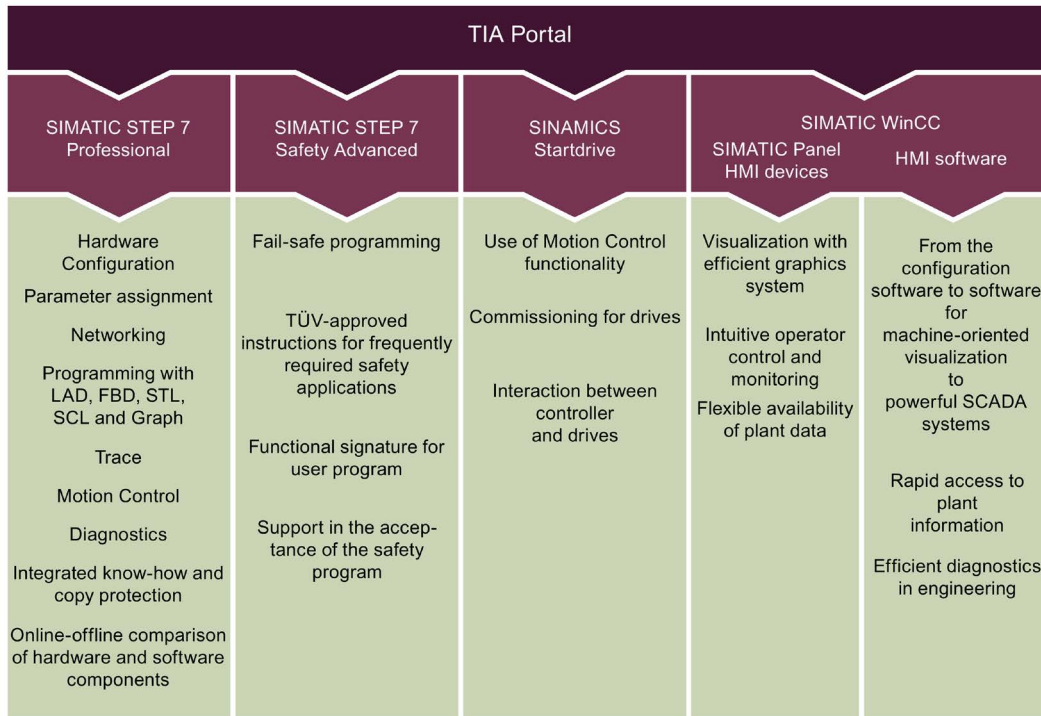

14.2 SIMATIC Automation Tool

You can use the free [SIMATIC Automation Tool](#) to run commissioning and maintenance activities simultaneously on various SIMATIC S7 stations as bulk operation independently of the TIA Portal. The SIMATIC Automation Tool provides a multitude of functions:

- Scanning of a PROFINET/Ethernet plant network and identification of all connected CPUs
- Address assignment (IP, subnet, gateway) and station name (PROFINET device) to a CPU
- Transfer of the date and the PG/PC time converted to UTC time to the module
- Program download to CPU
- Operating mode switchover RUN/STOP
- Localization of the CPU by means of LED flashing
- Reading out CPU error information
- Reading of CPU diagnostic buffer
- Reset to factory settings
- Updating the firmware of the CPU and connected modules

14.3 SINETPLAN

[SINETPLAN](#), the Siemens Network Planner, supports you in planning automation systems and networks based on PROFINET. The tool facilitates professional and predictive dimensioning of your PROFINET installation as early as in the planning stage. In addition, SINETPLAN supports you during network optimization and helps you to exploit network resources optimally and to plan reserves. Thus, problems in commissioning or failures during productive operation can be prevented even in advance of a planned operation. This increases the availability of the production plant and helps improve operational safety.

The advantages at a glance

- Network optimization thanks to port-specific calculation of the network load
- Increased production availability thanks to online scan and verification of existing systems
- Transparency before commissioning through importing and simulation of existing STEP 7 projects
- Efficiency through securing existing investment in the long term and optimal exploitation of resources

14.4 PRONETA

With SIEMENS PRONETA (PROFINET network analysis), you analyze the plant network during commissioning. PRONETA features two core functions:

- The topology overview independently scans PROFINET and all connected components.
- The IO check is a fast test of the wiring and the module configuration of a plant.

[SIEMENS PRONETA](#) is also available to you for free on the Internet.

14.5 SIMATIC S7 app

With the [SIMATIC S7 app](#) you can establish a secure connection via WLAN to SIMATIC S7-1500 and ET 200SP with the following functions:

- Detect up to 50 networked CPUs via HTTPS and establish a connection
- Change CPU operating mode (RUN/STOP)
- Read out CPU diagnostics information and send via e-mail
- Monitor and modify variables and tags
- High security through encrypted communication and encrypted profile data; password to start app and establish the connection

15 Additional information

15.1 Documentation of the system

The documentation for the SIMATIC S7-1500 automation system is divided into three areas:

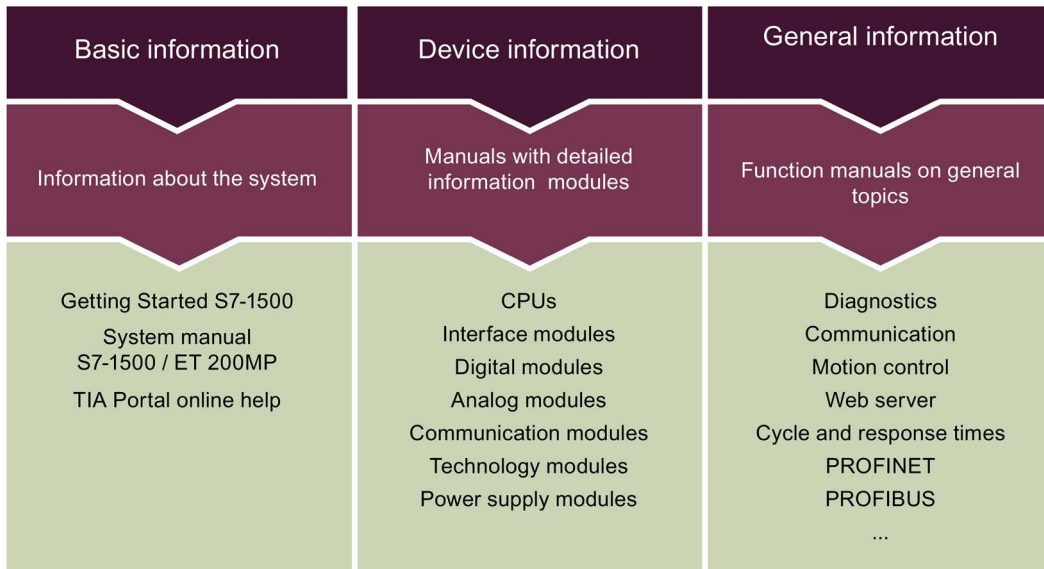

The [system manual](#) describes in detail the installation, wiring, configuration and commissioning of the system. You can find an overview of the documentation on the [Internet](#).

The Manual Collection contains the complete documentation for SIMATIC S7-1500 and ET 200MP. You can find the Manual Collection on the [Internet](#).

For new SIMATIC users, a [multimedia Getting Started](#) is available for S7-1500 and the TIA Portal in the Product Support.

Assembling your own documentation

In the Siemens Industry Online Support, the "[Documentation](#)" function enables you to compile your own "documentation" from the manuals found in the Product Support section. Other Product Support contents such as FAQs or characteristics can also be added to these compilations.

15.2 Application examples and tools

[Application examples and tools](#) support you in solving your automation tasks. Solutions are shown in interplay with multiple components - separated from the focus on individual products.

15.3 CAx downloads

Siemens offers you efficient access to all available CAx-relevant data via the [CAx downloads](#).

These support you in the electrotechnical and mechanical planning of a control cabinet, for example.

15.4 FAQs

To make it easier for you to get started with plant planning with SIMATIC controllers, an overview of important and frequently asked questions about SIMATIC S7-1500 is provided below.

- [Which SIMATIC and SITOP modules can you use with S7-1500 as load power supply module \(PM\)?](#)
- [Which panels can communicate with a SIMATIC S7-1200 or S7-1500 in the TIA Portal?](#)
- [How should you configure the system power supplies for the S7-1500 in STEP 7 \(TIA Portal\) so that all the connected modules are supplied?](#)
- [How do you load a project into the CPU in STEP 7 \(TIA Portal\)?](#)
- [How do you load the project data from the CPU into the programming device in STEP 7 \(TIA Portal\)?](#)
- [How do you configure the S7-1500 if modules in the physical configuration are missing compared with configuration or are in a different slot?](#)
- [How do you synchronize projects for the S7-1500 in STEP 7 \(TIA Portal\) when multiple users are working on a task at the same time?](#)
- [How do you estimate the memory requirements of your program in the load memory of the S7-1500 CPU and the ET 200SP CPU \(Open Controller\)?](#)
- [What options does the S7-1500 provide for downloading data in RUN?](#)
- [Why is universal definition and utilization of symbols in STEP 7 \(TIA Portal\) V12 obligatory for the S7-1500?](#)
- [What is the meaning of the system constants in STEP 7 \(TIA Portal\) with S7-1200/1500?](#)

A comprehensive selection of additional FAQs is available on the [Internet](#).

Validity

This document supplements the product documentation for SIMATIC S7-1500/ET 200MP.

Make sure that the product documentation is available for all activities with the product.

Disclaimer of liability

We have reviewed the contents of this publication to ensure consistency with the hardware and software described. However, since deviations cannot be precluded entirely, we cannot guarantee full consistency. The information in this publication is reviewed regularly and any necessary corrections are included in subsequent editions.
