

SIEMENS

SINAMICS/SIMOTICS

SINAMICS V90, SIMOTICS S-1FL6

Getting Started

<u>Fundamental safety instructions</u>	1
<u>General information</u>	2
<u>Mounting</u>	3
<u>Connecting</u>	4
<u>Commissioning</u>	5
<u>Parameters</u>	6
<u>Diagnostics</u>	7

Pulse train, USS/Modbus interface



12/2018

A5E36037886-006

Legal information

Warning notice system

This manual contains notices you have to observe in order to ensure your personal safety, as well as to prevent damage to property. The notices referring to your personal safety are highlighted in the manual by a safety alert symbol, notices referring only to property damage have no safety alert symbol. These notices shown below are graded according to the degree of danger.

 DANGER
indicates that death or severe personal injury will result if proper precautions are not taken.
 WARNING
indicates that death or severe personal injury may result if proper precautions are not taken.
 CAUTION
indicates that minor personal injury can result if proper precautions are not taken.
NOTICE
indicates that property damage can result if proper precautions are not taken.

If more than one degree of danger is present, the warning notice representing the highest degree of danger will be used. A notice warning of injury to persons with a safety alert symbol may also include a warning relating to property damage.

Qualified Personnel

The product/system described in this documentation may be operated only by **personnel qualified** for the specific task in accordance with the relevant documentation, in particular its warning notices and safety instructions. Qualified personnel are those who, based on their training and experience, are capable of identifying risks and avoiding potential hazards when working with these products/systems.

Proper use of Siemens products

Note the following:

 WARNING
Siemens products may only be used for the applications described in the catalog and in the relevant technical documentation. If products and components from other manufacturers are used, these must be recommended or approved by Siemens. Proper transport, storage, installation, assembly, commissioning, operation and maintenance are required to ensure that the products operate safely and without any problems. The permissible ambient conditions must be complied with. The information in the relevant documentation must be observed.

Trademarks

All names identified by ® are registered trademarks of Siemens AG. The remaining trademarks in this publication may be trademarks whose use by third parties for their own purposes could violate the rights of the owner.

Disclaimer of Liability

We have reviewed the contents of this publication to ensure consistency with the hardware and software described. Since variance cannot be precluded entirely, we cannot guarantee full consistency. However, the information in this publication is reviewed regularly and any necessary corrections are included in subsequent editions.

Table of contents

1	Fundamental safety instructions	5
1.1	General safety instructions	5
1.2	Equipment damage due to electric fields or electrostatic discharge	11
1.3	Warranty and liability for application examples	11
1.4	Industrial security	12
1.5	Residual risks of power drive systems.....	13
2	General information	14
2.1	Scope of delivery	14
2.1.1	Drive components	14
2.1.2	Motor components	19
2.2	Device combination.....	23
2.3	Accessories.....	26
2.4	Function list.....	28
2.5	Technical data.....	29
2.5.1	Technical data - servo drives.....	29
2.5.2	Technical data - servo motors	32
2.5.3	Address of CE-authorized manufacturer	36
3	Mounting	37
3.1	Mounting the drive	37
3.2	Mounting the motor	44
4	Connecting	52
4.1	System connection.....	52
4.2	Main circuit wiring	60
4.2.1	Line supply - L1, L2, L3	60
4.2.2	Motor power - U, V, W	62
4.3	Control/Status interface - X8.....	64
4.3.1	Interface definition.....	64
4.3.2	Standard wiring.....	67
4.4	24 V power supply/STO.....	71
4.5	Encoder interface - X9	73
4.6	External braking resistor - DCP, R1.....	76
4.7	Motor holding brake	77
4.8	RS485 interface - X12	77
5	Commissioning	78

5.1	Introduction to the BOP.....	79
5.2	Initial commissioning in JOG mode.....	85
5.3	Commissioning in pulse train position control mode (PTI)	88
5.4	Commissioning control functions	90
5.4.1	Selecting a control mode	90
5.4.2	Selecting a setpoint pulse train input channel	91
5.4.3	Selecting a setpoint pulse train input form.....	91
5.4.4	In position (INP)	92
5.4.5	Calculating electronic gear ratio.....	93
5.4.6	Absolute position system	95
6	Parameters	96
6.1	Overview	96
6.2	Parameter list.....	97
7	Diagnostics	131
7.1	Overview	131
7.2	List of faults and alarms	134
	Index.....	137

Fundamental safety instructions

1.1 General safety instructions



! WARNING

Electric shock and danger to life due to other energy sources

Touching live components can result in death or severe injury.

- Only work on electrical devices when you are qualified for this job.
- Always observe the country-specific safety rules.

Generally, the following six steps apply when establishing safety:

1. Prepare for disconnection. Notify all those who will be affected by the procedure.
2. Isolate the drive system from the power supply and take measures to prevent it being switched back on again.
3. Wait until the discharge time specified on the warning labels has elapsed.
4. Check that there is no voltage between any of the power connections, and between any of the power connections and the protective conductor connection.
5. Check whether the existing auxiliary supply circuits are de-energized.
6. Ensure that the motors cannot move.
7. Identify all other dangerous energy sources, e.g. compressed air, hydraulic systems, or water. Switch the energy sources to a safe state.
8. Check that the correct drive system is completely locked.

After you have completed the work, restore the operational readiness in the inverse sequence.



! WARNING

Risk of electric shock and fire from supply networks with an excessively high impedance

Excessively low short-circuit currents can lead to the protective devices not tripping or tripping too late, and thus causing electric shock or a fire.

- In the case of a conductor-conductor or conductor-ground short-circuit, ensure that the short-circuit current at the point where the inverter is connected to the line supply at least meets the minimum requirements for the response of the protective device used.
- You must use an additional residual-current device (RCD) if a conductor-ground short circuit does not reach the short-circuit current required for the protective device to respond. The required short-circuit current can be too low, especially for TT supply systems.



! WARNING

Risk of electric shock and fire from supply networks with an excessively low impedance

Excessively high short-circuit currents can lead to the protective devices not being able to interrupt these short-circuit currents and being destroyed, and thus causing electric shock or a fire.

- Ensure that the prospective short-circuit current at the line terminal of the inverter does not exceed the breaking capacity (SCCR or I_{cc}) of the protective device used.



! WARNING

Electric shock if there is no ground connection

For missing or incorrectly implemented protective conductor connection for devices with protection class I, high voltages can be present at open, exposed parts, which when touched, can result in death or severe injury.

- Ground the device in compliance with the applicable regulations.



! WARNING

Electric shock due to connection to an unsuitable power supply

When equipment is connected to an unsuitable power supply, exposed components may carry a hazardous voltage that might result in serious injury or death.

- Only use power supplies that provide SELV (Safety Extra Low Voltage) or PELV- (Protective Extra Low Voltage) output voltages for all connections and terminals of the electronics modules.



! WARNING

Electric shock due to damaged motors or devices

Improper handling of motors or devices can damage them.

Hazardous voltages can be present at the enclosure or at exposed components on damaged motors or devices.

- Ensure compliance with the limit values specified in the technical data during transport, storage and operation.
- Do not use any damaged motors or devices.



! WARNING

Electric shock due to unconnected cable shields

Hazardous touch voltages can occur through capacitive cross-coupling due to unconnected cable shields.

- As a minimum, connect cable shields and the cores of cables that are not used at one end at the grounded housing potential.



! WARNING

Arcing when a plug connection is opened during operation

Opening a plug connection when a system is operation can result in arcing that may cause serious injury or death.

- Only open plug connections when the equipment is in a voltage-free state, unless it has been explicitly stated that they can be opened in operation.



! WARNING

Electric shock due to residual charges in power components

Because of the capacitors, a hazardous voltage is present for up to 5 minutes after the power supply has been switched off. Contact with live parts can result in death or serious injury.

- Wait for 5 minutes before you check that the unit really is in a no-voltage condition and start work.

NOTICE

Property damage due to loose power connections

Insufficient tightening torques or vibration can result in loose power connections. This can result in damage due to fire, device defects or malfunctions.

- Tighten all power connections to the prescribed torque.
- Check all power connections at regular intervals, particularly after equipment has been transported.

! WARNING

Spread of fire from built-in devices

In the event of fire outbreak, the enclosures of built-in devices cannot prevent the escape of fire and smoke. This can result in serious personal injury or property damage.

- Install built-in units in a suitable metal cabinet in such a way that personnel are protected against fire and smoke, or take other appropriate measures to protect personnel.
- Ensure that smoke can only escape via controlled and monitored paths.

! WARNING

Active implant malfunctions due to electromagnetic fields

Inverters generate electromagnetic fields (EMF) in operation. People with active implants in the immediate vicinity of this equipment are at particular risk.

- As the operator of an EMF-emitting installation, assess the individual risks of persons with active implants. The following clearances are usually adequate:
 - No clearance to closed control cabinets and shielded MOTION-CONNECT supply cables
 - Forearm length (approx. 35 cm clearance) to distributed drive systems and open control cabinets

 **WARNING**

Active implant malfunctions due to permanent-magnet fields

Even when switched off, electric motors with permanent magnets represent a potential risk for persons with heart pacemakers or implants if they are close to converters/motors.

- If you have a heart pacemaker or implant, maintain a minimum distance of 2 m.
- When transporting or storing permanent-magnet motors always use the original packing materials with the warning labels attached.
- Clearly mark the storage locations with the appropriate warning labels.
- IATA regulations must be observed when transported by air.

 **WARNING**

Unexpected movement of machines caused by radio devices or mobile phones

When radio devices or mobile phones with a transmission power > 1 W are used in the immediate vicinity of components, they may cause the equipment to malfunction. Malfunctions may impair the functional safety of machines and can therefore put people in danger or lead to property damage.

- If you come closer than around 2 m to such components, switch off any radios or mobile phones.
- Use the "SIEMENS Industry Online Support app" only on equipment that has already been switched off.

NOTICE

Damage to motor insulation due to excessive voltages

When operated on systems with grounded line conductor or in the event of a ground fault in the IT system, the motor insulation can be damaged by the higher voltage to ground. If you use motors that have insulation that is not designed for operation with grounded line conductors, you must perform the following measures:

- IT system: Use a ground fault monitor and eliminate the fault as quickly as possible.
- TN or TT systems with grounded line conductor: Use an isolating transformer on the line side.

 **WARNING**

Fire due to inadequate ventilation clearances

Inadequate ventilation clearances can cause overheating of components with subsequent fire and smoke. This can cause severe injury or even death. This can also result in increased downtime and reduced service lives for devices/systems.

- Ensure compliance with the specified minimum clearance as ventilation clearance for the respective component.

 WARNING**Unrecognized dangers due to missing or illegible warning labels**

Dangers might not be recognized if warning labels are missing or illegible. Unrecognized dangers may cause accidents resulting in serious injury or death.

- Check that the warning labels are complete based on the documentation.
- Attach any missing warning labels to the components, where necessary in the national language.
- Replace illegible warning labels.

NOTICE**Device damage caused by incorrect voltage/insulation tests**

Incorrect voltage/insulation tests can damage the device.

- Before carrying out a voltage/insulation check of the system/machine, disconnect the devices as all converters and motors have been subject to a high voltage test by the manufacturer, and therefore it is not necessary to perform an additional test within the system/machine.

 WARNING**Unexpected movement of machines caused by inactive safety functions**

Inactive or non-adapted safety functions can trigger unexpected machine movements that may result in serious injury or death.

- Observe the information in the appropriate product documentation before commissioning.
- Carry out a safety inspection for functions relevant to safety on the entire system, including all safety-related components.
- Ensure that the safety functions used in your drives and automation tasks are adjusted and activated through appropriate parameterizing.
- Perform a function test.
- Only put your plant into live operation once you have guaranteed that the functions relevant to safety are running correctly.

Note**Important safety notices for Safety Integrated functions**

If you want to use Safety Integrated functions, you must observe the safety notices in the Safety Integrated manuals.

 WARNING
Malfunctions of the machine as a result of incorrect or changed parameter settings As a result of incorrect or changed parameterization, machines can malfunction, which in turn can lead to injuries or death. <ul style="list-style-type: none">• Protect the parameterization (parameter assignments) against unauthorized access.• Handle possible malfunctions by taking suitable measures, e.g. emergency stop or emergency off.

 WARNING
Injury caused by moving or ejected parts Contact with moving motor parts or drive output elements and the ejection of loose motor parts (e.g. feather keys) out of the motor enclosure can result in severe injury or death. <ul style="list-style-type: none">• Remove any loose parts or secure them so that they cannot be flung out.• Do not touch any moving parts.• Safeguard all moving parts using the appropriate safety guards.

 WARNING
Fire due to inadequate cooling Inadequate cooling can cause the motor to overheat, resulting in death or severe injury as a result of smoke and fire. This can also result in increased failures and reduced service lives of motors. <ul style="list-style-type: none">• Comply with the specified cooling requirements for the motor.

 WARNING
Fire due to incorrect operation of the motor When incorrectly operated and in the case of a fault, the motor can overheat resulting in fire and smoke. This can result in severe injury or death. Further, excessively high temperatures destroy motor components and result in increased failures as well as shorter service lives of motors. <ul style="list-style-type: none">• Operate the motor according to the relevant specifications.• Only operate the motors in conjunction with effective temperature monitoring.• Immediately switch off the motor if excessively high temperatures occur.



 CAUTION
Burn injuries caused by hot surfaces In operation, the motor can reach high temperatures, which can cause burns if touched. <ul style="list-style-type: none">• Mount the motor so that it is not accessible in operation. Measures when maintenance is required: <ul style="list-style-type: none">• Allow the motor to cool down before starting any work.• Use the appropriate personnel protection equipment, e.g. gloves.

1.2 Equipment damage due to electric fields or electrostatic discharge

Electrostatic sensitive devices (ESD) are individual components, integrated circuits, modules or devices that may be damaged by either electric fields or electrostatic discharge.



NOTICE

Equipment damage due to electric fields or electrostatic discharge

Electric fields or electrostatic discharge can cause malfunctions through damaged individual components, integrated circuits, modules or devices.

- Only pack, store, transport and send electronic components, modules or devices in their original packaging or in other suitable materials, e.g. conductive foam rubber or aluminum foil.
- Only touch components, modules and devices when you are grounded by one of the following methods:
 - Wearing an ESD wrist strap
 - Wearing ESD shoes or ESD grounding straps in ESD areas with conductive flooring
- Only place electronic components, modules or devices on conductive surfaces (table with ESD surface, conductive ESD foam, ESD packaging, ESD transport container).

1.3 Warranty and liability for application examples

Application examples are not binding and do not claim to be complete regarding configuration, equipment or any eventuality which may arise. Application examples do not represent specific customer solutions, but are only intended to provide support for typical tasks.

As the user you yourself are responsible for ensuring that the products described are operated correctly. Application examples do not relieve you of your responsibility for safe handling when using, installing, operating and maintaining the equipment.

1.4 Industrial security

Note

Industrial security

Siemens provides products and solutions with industrial security functions that support the secure operation of plants, systems, machines and networks.

In order to protect plants, systems, machines and networks against cyber threats, it is necessary to implement – and continuously maintain – a holistic, state-of-the-art industrial security concept. Siemens' products and solutions constitute one element of such a concept.

Customers are responsible for preventing unauthorized access to their plants, systems, machines and networks. Such systems, machines and components should only be connected to an enterprise network or the Internet if and to the extent such a connection is necessary and only when appropriate security measures (e.g. firewalls and/or network segmentation) are in place.

For additional information on industrial security measures that may be implemented, please visit:

Industrial security (<http://www.siemens.com/industrialsecurity>)

Siemens' products and solutions undergo continuous development to make them more secure. Siemens strongly recommends that product updates are applied as soon as they are available and that the latest product versions are used. Use of product versions that are no longer supported, and failure to apply the latest updates may increase customer's exposure to cyber threats.

To stay informed about product updates, subscribe to the Siemens Industrial Security RSS Feed at:

Industrial security (<http://www.siemens.com/industrialsecurity>)

Further information is provided on the Internet:

Industrial Security Configuration Manual

(<https://support.industry.siemens.com/cs/ww/en/view/108862708>)

WARNING

Unsafe operating states resulting from software manipulation

Software manipulations (e.g. viruses, trojans, malware or worms) can cause unsafe operating states in your system that may lead to death, serious injury, and property damage.

- Keep the software up to date.
- Incorporate the automation and drive components into a holistic, state-of-the-art industrial security concept for the installation or machine.
- Make sure that you include all installed products into the holistic industrial security concept.
- Protect files stored on exchangeable storage media from malicious software by with suitable protection measures, e.g. virus scanners.
- Protect the drive against unauthorized changes by activating the "know-how protection" drive function.

1.5 Residual risks of power drive systems

When assessing the machine- or system-related risk in accordance with the respective local regulations (e.g., EC Machinery Directive), the machine manufacturer or system installer must take into account the following residual risks emanating from the control and drive components of a drive system:

1. Unintentional movements of driven machine or system components during commissioning, operation, maintenance, and repairs caused by, for example,
 - Hardware and/or software errors in the sensors, control system, actuators, and cables and connections
 - Response times of the control system and of the drive
 - Operation and/or environmental conditions outside the specification
 - Condensation/conductive contamination
 - Parameterization, programming, cabling, and installation errors
 - Use of wireless devices/mobile phones in the immediate vicinity of electronic components
 - External influences/damage
 - X-ray, ionizing radiation and cosmic radiation
2. Unusually high temperatures, including open flames, as well as emissions of light, noise, particles, gases, etc., can occur inside and outside the components under fault conditions caused by, for example:
 - Component failure
 - Software errors
 - Operation and/or environmental conditions outside the specification
 - External influences/damage
3. Hazardous shock voltages caused by, for example:
 - Component failure
 - Influence during electrostatic charging
 - Induction of voltages in moving motors
 - Operation and/or environmental conditions outside the specification
 - Condensation/conductive contamination
 - External influences/damage
4. Electrical, magnetic and electromagnetic fields generated in operation that can pose a risk to people with a pacemaker, implants or metal replacement joints, etc., if they are too close
5. Release of environmental pollutants or emissions as a result of improper operation of the system and/or failure to dispose of components safely and correctly
6. Influence of network-connected communication systems, e.g. ripple-control transmitters or data communication via the network

For more information about the residual risks of the drive system components, see the relevant sections in the technical user documentation.

General information

The SINAMICS V90 drives are available in two variants, 400 V variant and 200 V variant.



The 200 V variant is available in four frame sizes: FSA, FSB, FSC, and FSD. Frame sizes A, B, and C are used on the single phase or three phase power network while frame size D is used on the three phase power network only.

The 400 V variant is also available in four frame sizes: FSAA, FSA, FSB, and FSC. All the frame sizes are used on three phase power network only.



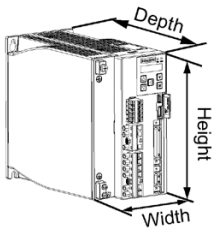

2.1 Scope of delivery

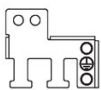
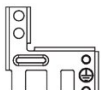
2.1.1 Drive components

Components in SINAMICS V90 200 V variant drive package

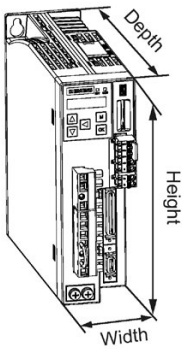
Component	Illustration	Rated power (kW)	Outline dimension (Width x Height x Depth, mm)	Frame size	Article number	
SINAMICS V90, single/three-phase, 200 V		0.1/0.2	45 x 170 x 170	FSA	6SL3210-5FB10-1UA2 6SL3210-5FB10-2UA2	
		0.4	55 x 170 x 170	FSB	6SL3210-5FB10-4UA1	
		0.75	80 x 170 x 195	FSC	6SL3210-5FB10-8UA0	
SINAMICS V90, three-phase, 200 V		1.0/1.5/2.0	95 x 170 x 195	FSD	6SL3210-5FB11-0UA1 6SL3210-5FB11-5UA0 6SL3210-5FB12-0UA0	
		Connectors		For FSA and FSB		
				For FSC and FSD		
Shielding plate		For FSA and FSB				
		For FSC and FSD				
User documentation	Information Guide	English-Chinese bilingual version				

Components in SINAMICS V90 400 V variant drive package

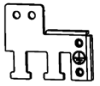
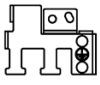
Component	Illustration	Rated power (kW)	Outline dimension (Width x Height x Depth, mm)	Frame size	Article number
SINAMICS V90, three-phase, 400 V		0.4	60 x 180 x 200	FSAA	6SL3210-5FE10-4UA0
		0.75/1.0	80 x 180 x 200	FSA	6SL3210-5FE10-8UA0 6SL3210-5FE11-0UA0
		1.5/2.0	100 x 180 x 220	FSB	6SL3210-5FE11-5UA0 6SL3210-5FE12-0UA0
		3.5/5.0/7.0	140 x 260 x 240	FSC	6SL3210-5FE13-5UA0
					6SL3210-5FE15-0UA0
					6SL3210-5FE17-0UA0
Connectors		For FSAA			
		For FSA			
		For FSB and FSC			
Shielding plate		For FSAA and FSA			
		For FSB and FSC			
User documentation	Information Guide	English-Chinese bilingual version			

Drive rating plate (example)

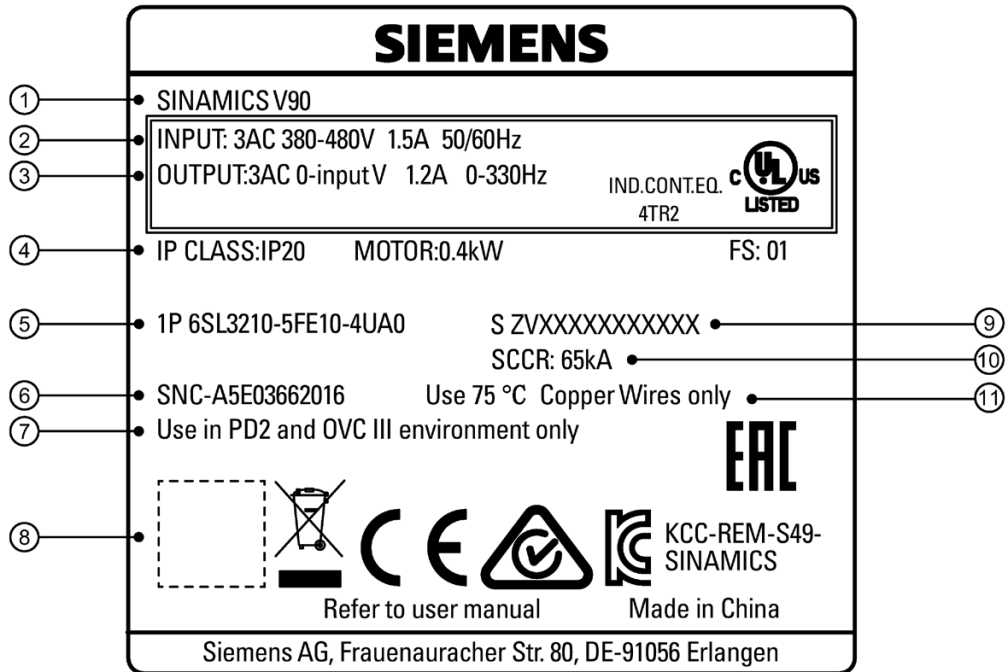

- | | |
|---------------------|---|
| ① Drive name | ⑦ Pollution degree and overvoltage criteria |
| ② Power input | ⑧ QR code |
| ③ Power output | ⑨ Product serial number |
| ④ Rated motor power | ⑩ Rated short-circuit current |
| ⑤ Article number | ⑪ Copper wire |
| ⑥ Part number | |

Article number explanation (example)

6 S L 3 2 1 0 - 5 F E 1 0 - 4 U A 0

Supply voltage

Symbol	Supply voltage
B	1/3 phase 200~240 VAC
E	3 phase 380~480 VAC

Drive version

Symbol	Drive version
A	V90 Pulse train (PTI) version
F	V90 PROFINET (PN) version

Supported max motor power

Symbol	Supported max motor power	Supply voltage
10-1	0.1 kW	200 V
10-2	0.2 kW	200 V
10-4	0.4 kW	200 V
	0.4 kW	400 V
10-8	0.75 kW	200 V
	0.75 kW	400 V
11-0	1.0 kW	200 V
	1.0 kW	400 V
11-5	1.5 kW	200 V
	1.75 kW	400 V
12-0	2.0 kW	200 V
	2.5 kW	400 V
13-5	3.5 kW	400 V
15-0	5.0 kW	400 V
17-0	7.0 kW	400 V

Serial number explanation (example)

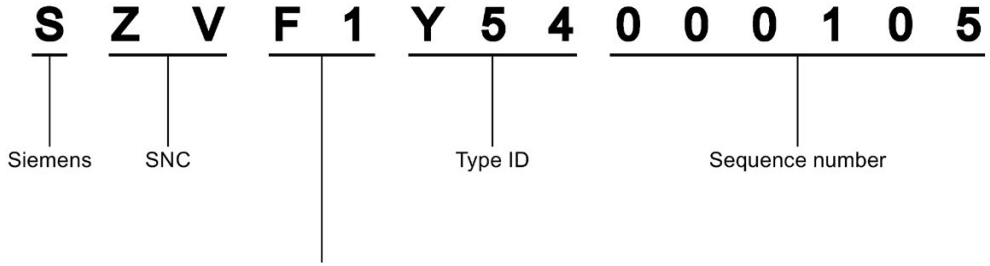

Production date (year/month)

Code	Calendar year	Code	Month
A	2010, 2030	1	January
B	2011, 2031	2	February
C	2012, 2032	3	March
D	2013, 2033	4	April
E	2014, 2034	5	May
F	2015, 2035	6	June
H	2016, 2036	7	July
J	2017, 2037	8	August
K	2018, 2038	9	September
L	2019, 2039	0	October
M	2020, 2040	N	November
N	2021, 2041	D	December
P	2022, 2042		
R	2023, 2043		
S	2024, 2044		
T	2025, 2045		
U	2026, 2046		
V	2027, 2047		
W	2028, 2048		
X	2029, 2049		

2.1.2 Motor components

Components in the SIMOTICS S-1FL6 low inertia motor package

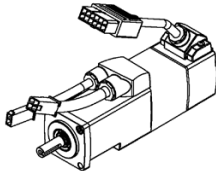
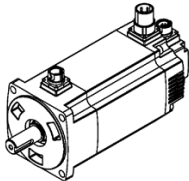
Component	Illustration	Rated power (kW)	Shaft height (mm)	Article number
SIMOTICS S-1FL6, low inertia		0.05/0.1	20	1FL6022-2AF21-1□□1
				1FL6024-2AF21-1□□1
		0.2/0.4	30	1FL6032-2AF21-1□□1
				1FL6034-2AF21-1□□1
		0.75/1.0	40	1FL6042-2AF21-1□□1
				1FL6044-2AF21-1□□1
		1.5/2.0	50	1FL6052-2AF21-0□□1
				1FL6054-2AF21-0□□1
		1.5/2.0	50	1FL6052-2AF21-2□□1
				1FL6054-2AF21-2□□1
User documentation	SIMOTICS S-1FL6 Servo Motors Installation Guide			

Note: For the SH50 motors with a multi-turn absolute encoder, only angular connector version is available.

Components in the SIMOTICS S-1FL6 high inertia motor package

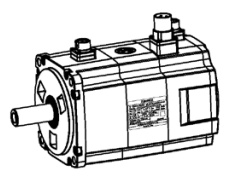
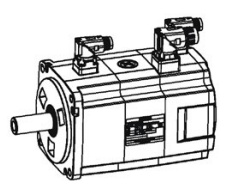
Component	Illustration	Rated power (kW)	Shaft height (mm)	Article number				
SIMOTICS S-1FL6, high inertia		0.4/0.75	45	1FL6042-1AF61-	<input type="checkbox"/>	□□1		
				1FL6044-1AF61-	<input type="checkbox"/>	□□1		
		0.75/1.0/1.5/1.7 5/2.0	65	1FL6061-1AC61-	<input type="checkbox"/>	□□1		
				1FL6062-1AC61-	<input type="checkbox"/>	□□1		
				1FL6064-1AC61-	<input type="checkbox"/>	□□1		
				1FL6066-1AC61-	<input type="checkbox"/>	□□1		
				1FL6067-1AC61-	<input type="checkbox"/>	□□1		
		2.5/3.5/5.0/7.0	90	1FL6090-1AC61-	<input type="checkbox"/>	□□1		
				1FL6092-1AC61-	<input type="checkbox"/>	□□1		
				1FL6094-1AC61-	<input type="checkbox"/>	□□1		
				1FL6096-1AC61-	<input type="checkbox"/>	□□1		
			Straight connectors with a fixed outlet direction			0		
			Angular connectors with a flexible outlet direction			2		
		User documentation	SIMOTICS S-1FL6 Servo Motors Installation Guide					

Motor rating plate (example)

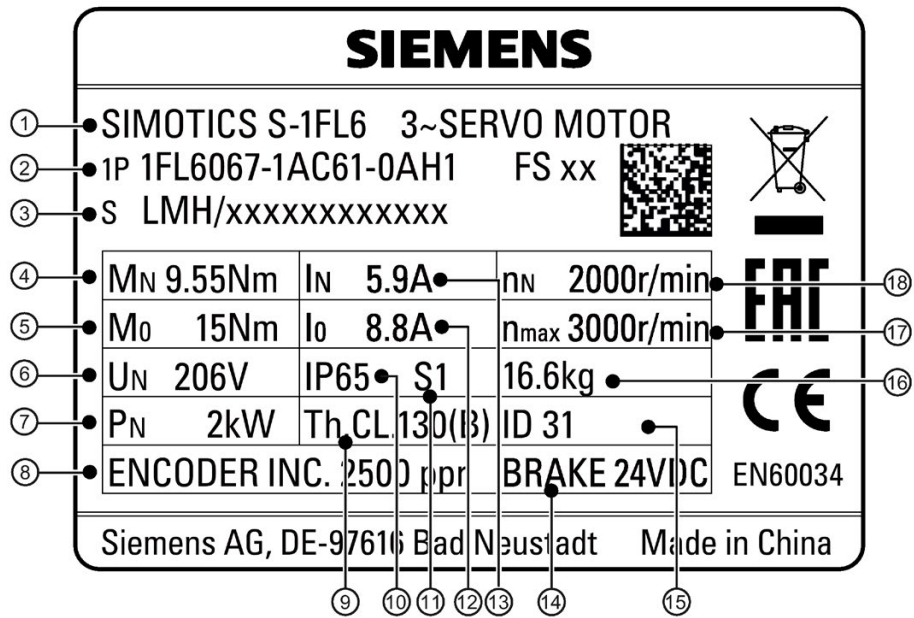

- | | |
|-------------------------------|------------------------|
| ① Motor type | ⑩ Degree of protection |
| ② Article number | ⑪ Motor operating mode |
| ③ Serial number | ⑫ Stall current |
| ④ Rated torque | ⑬ Rated current |
| ⑤ Stall torque | ⑭ Holding brake |
| ⑥ Rated voltage | ⑮ Motor ID |
| ⑦ Rated power | ⑯ Weight |
| ⑧ Encoder type and resolution | ⑰ Maximum speed |
| ⑨ Thermal class | ⑱ Rated speed |

Article number explanation

1 F L 6 0 6 7 - 1 A C 6 1 - 0 A H 1

Shaft height (SH)

Symbol	SH	Inertia type
02	20 mm	Low
03	30 mm	Low
04	40 mm	Low
	45 mm	High
05	50 mm	Low
06	65 mm	High
09	90 mm	High

Inertia type

Symbol	Type
1	High
2	Low

Supply voltage

Symbol	Voltage
2	200 V
6	400 V

Rated speed

Symbol	Rated speed
C	2000 rpm
F	3000 rpm

Rated torque

Symbol	Rated torque, SH
0	11.9 Nm, SH90
1	3.58 Nm, SH65
2	0.16 Nm, SH20
	0.64 Nm, SH30
	1.27 Nm, SH45
	2.39 Nm, SH40
	4.78 Nm, SH50
	4.78 Nm, SH65
	16.7 Nm, SH90
4	0.32 Nm, SH20
	1.27 Nm, SH30
	2.39 Nm, SH45
	3.18 Nm, SH40
	6.37 Nm, SH50
	7.16 Nm, SH65
	23.9 Nm, SH90
6	8.36 Nm, SH65
	33.4 Nm, SH90
7	9.55 Nm, SH65

Connection type

Symbol	Connection type
0	Straight connectors with a fixed outlet direction
1	Cable outlet
2	Angular connectors with a flexible outlet direction

Encoder type

Symbol	Encoder type
A	Incremental encoder TTL 2500 ppr
M	Absolute encoder single-turn 21-bit
L	Absolute encoder 20-bit + 12-bit multi-turn

Mechanics

Symbol	Mechanics
G	Plain shaft, without brake
H	Plain shaft, with brake
A	Shaft with key (half-key balancing), without brake
B	Shaft with key (half-key balancing), with brake

Protection degree

Symbol	Protection degree
1	IP65, with shaft oil seal

2.2 Device combination

V90 200 V servo system

SIMOTICS S-1FL6 low inertia servo motors							SINAMICS V90 200 V servo drives		MOTION-CONNECT 300 pre-assembled cables				
Rated torque (Nm)	Rated power (kW)	Rated speed (rpm)	Shaft height (mm)	Article No. 1FL60			Article No. 6SL3210-5	Frame size	Article No. 6FX3002-5	Article No. 6FX3002-5	Encoder cable		
											Power cable	Brake cable	Article No. 6FX3002-2
0.16	0.05	3000	20	22-2AF21-1	<input type="checkbox"/>	<input type="checkbox"/>	FB10-1UA2	FSA	CK01-....	BK02-....	<input type="checkbox"/>	20-....	
0.32	0.1	3000		24-2AF21-1	<input type="checkbox"/>	<input type="checkbox"/>							
0.64	0.2	3000	30	32-2AF21-1	<input type="checkbox"/>	<input type="checkbox"/>	FB10-2UA2	FSB	CK01-....	BK02-....	<input type="checkbox"/>	20-....	
1.27	0.4	3000		34-2AF21-1	<input type="checkbox"/>	<input type="checkbox"/>	FB10-4UA1						
2.39	0.75	3000	40	42-2AF21-1	<input type="checkbox"/>	<input type="checkbox"/>	FB10-8UA0	FSC	CK01-....	BK02-....	<input type="checkbox"/>	20-....	
3.18	1	3000		44-2AF21-1	<input type="checkbox"/>	<input type="checkbox"/>	FB11-0UA1	FSD					
4.78	1.5	3000	50	52-2AF21-0 ¹⁾	<input type="checkbox"/>	<input type="checkbox"/>	FB11-5UA0	FSD	CK31-....	BL02-....	<input type="checkbox"/>	10-....	
6.37	2	3000		54-2AF21-0 ¹⁾	<input type="checkbox"/>	<input type="checkbox"/>	FB12-0UA0						
4.78	1.5	3000	50	52-2AF21-2 ²⁾	<input type="checkbox"/>	<input type="checkbox"/>	FB11-5UA0	FSD	CK32-....	BL03-....	<input type="checkbox"/>	12-....	
6.37	2	3000		54-2AF21-2 ²⁾	<input type="checkbox"/>	<input type="checkbox"/>	FB12-0UA0						
Incremental encoder TTL 2500 ppr							A			Incremental encoder TTL 2500 ppr		CT	
Absolute encoder single-turn 21-bit							M			Absolute encoder single-turn 21-bit		DB	
Absolute encoder 20-bit + 12-bit multi-turn							L			Absolute encoder 20-bit + 12-bit multi-turn			
Cable length ³⁾													
3 m									1AD0				
5 m									1AF0				
10 m									1BA0				
20 m									1CA0				

Low inertia motor with straight connectors

Low inertia motor with angular connectors

The last four numbers in the cable article number (...)

V90 400 V servo system

SIMOTICS S-1FL6 high inertia servo motors with straight connectors							SINAMICS V90 400 V servo drives		MOTION-CONNECT 300 pre-assembled cables			
Rated torque (Nm)	Rated power (kW)	Rated speed (rpm)	Shaft height (mm)	Article No. 1FL60			Article No. 6SL3210-5	Frame size	Article No. 6FX3002-5	Article No. 6FX3002-5	Encoder cable	
1.27	0.4	3000	45	42-1AF61-0	<input type="checkbox"/>	<input type="checkbox"/>	FE10-4UA0	FSA	CL01-....	BL02-....	<input type="checkbox"/>	10-....
2.39	0.75	3000		44-1AF61-0	<input type="checkbox"/>	<input type="checkbox"/>	FE10-8UA0	FSA				
3.58	0.75	2000	65	61-1AC61-0	<input type="checkbox"/>	<input type="checkbox"/>	FE11-0UA0	FSB	CL11-....			
4.78	1.0	2000		62-1AC61-0	<input type="checkbox"/>	<input type="checkbox"/>						
7.16	1.5	2000		64-1AC61-0	<input type="checkbox"/>	<input type="checkbox"/>	FE11-5UA0					
8.36	1.75	2000		66-1AC61-0	<input type="checkbox"/>	<input type="checkbox"/>						
9.55	2.0	2000		67-1AC61-0	<input type="checkbox"/>	<input type="checkbox"/>	FE12-0UA0					
11.9	2.5	2000		90-1AC61-0	<input type="checkbox"/>	<input type="checkbox"/>						
16.7	3.5	2000	90	92-1AC61-0	<input type="checkbox"/>	<input type="checkbox"/>	FE13-5UA0	FSC				
23.9	5.0	2000		94-1AC61-0	<input type="checkbox"/>	<input type="checkbox"/>	FE15-0UA0					
33.4	7.0	2000		96-1AC61-0	<input type="checkbox"/>	<input type="checkbox"/>	FE17-0UA0					
Incremental encoder TTL 2500 ppr					A				Incremental encoder TTL 2500 ppr	CT		
Absolute encoder 20-bit + 12-bit multi-turn					L				Absolute encoder 20-bit + 12-bit multi-turn	DB		
Cable length ¹⁾												
3 m									1AD0			
5 m									1AF0			
7 m									1AH0			
10 m									1BA0			
15 m									1BF0			
20 m									1CA0			

The last four numbers in the cable article number (....)

SIMOTICS S-1FL6 high inertia servo motors with angular connectors							SINAMICS V90 400 V servo drives		MOTION-CONNECT 300 pre-assembled cables			
Rated torque (Nm)	Rated power (kW)	Rated speed (rpm)	Shaft height (mm)	Article No. 1FL60			Article No. 6SL3210-5	Frame size	Article No. 6FX3002-5	Article No. 6FX3002-5	Encoder cable	
1.27	0.4	3000	45	42-1AF61-2	□	□1	FE10-4UA0	FSA	CL02-....	BL03-....	□□□□	-....
2.39	0.75	3000		44-1AF61-2	□	□1	FE10-8UA0	FSA				
3.58	0.75	2000	65	61-1AC61-2	□	□1	FE11-0UA0	FSB	CL12-....			
4.78	1.0	2000		62-1AC61-2	□	□1						
7.16	1.5	2000		64-1AC61-2	□	□1	FE11-5UA0					
8.36	1.75	2000		66-1AC61-2	□	□1	FE12-0UA0					
9.55	2.0	2000		67-1AC61-2	□	□1						
11.9	2.5	2000		90	90-1AC61-2	□	□1					
16.7	3.5	2000	92-1AC61-2	□	□1	FE13-5UA0						
23.9	5.0	2000	94-1AC61-2	□	□1	FE15-0UA0						
33.4	7.0	2000	96-1AC61-2	□	□1	FE17-0UA0						
Incremental encoder TTL 2500 ppr						A			Incremental encoder TTL 2500 ppr	CT12		
Absolute encoder 20-bit + 12-bit multi-turn						L			Absolute encoder 20-bit + 12-bit multi-turn	DB10		
Cable length ¹⁾												
3 m									1AD0			
5 m									1AF0			
7 m									1AH0			
10 m									1BA0			
15 m									1BF0			
20 m									1CA0			

The last four numbers in the cable article number (...)

Note

You can select a SINAMICS V90 servo drive for all the SIMOTICS S-1FL6 servo motors whose rated power values are equal to or smaller than that specified as matching with this servo drive in the table above.

Note

Check the motor ID in the drive (p29000) and make sure that the value is that specified on the rating plate of the connected motor, especially when the drive is working with a motor whose rated power value is lower than that of this drive.

2.3 Accessories

Fuse/type E combination motor controller

A fuse/Type-E combination motor controller can be used to protect the system. Integral solid state short circuit protection does not provide branch circuit protection. Branch circuit protection must be provided in accordance with the National Electrical Code and any additional local codes. Refer to the following table for the selection of fuses and type E motor controllers:

SINAMICS V90 200 V variant

SINAMICS V90		Recommended fuse		Type-E combination motor controller ¹⁾			
Frame size	Rated power (kW)	CE-compliant	UL/cUL-compliant listed (JDDZ) fuse	Rated current (A)	Rated voltage (VAC)	Rated power (HP)	Article number
1-phase, 200 VAC to 240 VAC							
FSA	0.1	3NA3 801 (6 A)	6 A	2.8 to 4	230/240	1/3	3RV 2011-1EA10
	0.2	3NA3 801 (6 A)	6 A	2.8 to 4	230/240	1/3	3RV 2011-1EA10
FSB	0.4	3NA3 803 (10 A)	10 A	5.5 to 8	230/240	1	3RV 2011-1HA10
FSC	0.75	3NA3 805 (16 A)	20 A	9 to 12.5	230/240	2	3RV 2011-1KA10
3-phase, 200 VAC to 240 VAC							
FSA	0.1	3NA3 801 (6 A)	6 A	2.8 to 4	230/240	3/4	3RV 2011-1EA10
	0.2	3NA3 801 (6 A)	6 A	2.8 to 4	230/240	3/4	3RV 2011-1EA10
FSB	0.4	3NA3 803 (10 A)	10 A	2.8 to 4	230/240	3/4	3RV 2011-1EA10
FSC	0.75	3NA3 805 (16 A)	20 A	5.5 to 8	230/240	2	3RV 2011-1HA10
FSD	1.0	3NA3 805 (16 A)	20 A	7 to 10	230/240	3	3RV 2011-1JA10
	1.5	3NA3 810 (25 A)	25 A	10 to 16	230/240	5	3RV 2011-4AA10
	2.0	3NA3 810 (25 A)	25 A	10 to 16	230/240	5	3RV 2011-4AA10

The above types for Type-E combination motor controllers are listed in compliance with both CE and UL/cUL standards.

SINAMICS V90 400 V variant

SINAMICS V90		Recommended fuse type		Type E combination motor controller ¹⁾			
Frame size	Rated power (kW)	CE-compliant	UL/cUL-compliant listed (JDDZ) fuse	Rated current (A)	Rated voltage (VAC)	Rated power (HP)	Article number
3-phase, 380 VAC to 480 VAC							
FSA	0.4	3NA3 801-6 (6 A)	10 A	2.2 to 3.2	380/480	0.5	3RV 2021-1DA10
FSA	0.75	3NA3 801-6 (6 A)	10 A	2.8 to 4	380/480	1	3RV 2021-1EA10
	1.0	3NA3 803-6 (10 A)	10 A	3.5 to 5	380/480	1.34	3RV 2021-1FA10
FSB	1.5	3NA3 803-6 (10 A)	15 A	5.5 to 8	380/480	2	3RV 2021-1HA10
	2.0	3NA3 805-6 (16 A)	15 A	11 to 16	380/480	2.68	3RV 2021-4AA10
FSC	3.5	3NA3 807-6 (20 A)	25 A	14 to 20	380/480	4.7	3RV 2021-4BA10
	5.0	3NA3 807-6 (20 A)	25 A	14 to 20	380/480	6.7	3RV 2021-4BA10
	7.0	3NA3 810-6 (25 A)	25 A	20 to 25	380/480	9.4	3RV 2021-4DA10

The above types for Type-E combination motor controllers are listed in compliance with both CE and UL/cUL standards.

⚠ WARNING**Requirements for United States/Canadian installations (UL/cUL)**

Suitable for use on a circuit capable of delivering not more than 65000 rms Symmetrical Amperes, 480 VAC maximum for 400 V variants of drives or 240 VAC maximum for 200 V variant drives, when protected by UL/cUL listed (JDDZ) fuse or type E combination motor controller. For each frame size AA, A, B, C and D, use 75 °C copper wire only.

This equipment is capable of providing internal motor overload protection according to UL508C.

For Canadian (cUL) installations the drive mains supply must be fitted with any external recommended suppressor with the following features:

- Surge-protective devices; device shall be a Listed Surge-protective device (Category code VZCA and VZCA7)
- Rated nominal voltage 480/277 VAC, 50/60 Hz, 3-phase
- Clamping voltage VPR = 2000 V, IN = 3kA min, MCOV = 508 VAC, SCCR = 65 kA
- Suitable for Type 2 SPD application
- Clamping shall be provided between phases and also between phase and ground

Product maintenance

The components are subject to continuous further development within the scope of product maintenance (improvements to robustness, discontinuations of components, etc).

These further developments are "spare parts-compatible" and do not change the article number.

In the scope of such spare parts-compatible further developments, connector positions are sometimes changed slightly. This does not cause any problems with proper use of the components. Please take this fact into consideration in special installation situations (e.g. allow sufficient clearance for the cable length).

Use of third-party products

This document contains recommendations relating to third-party products. Siemens accepts the fundamental suitability of these third-party products.

You can use equivalent products from other manufacturers.

Siemens does not accept any warranty for the properties of third-party products.

Recycling and disposal



For environmentally-friendly recycling and disposal of your old device, please contact a company certified for the disposal of waste electrical and electronic equipment, and dispose of the old device as prescribed in the respective country of use.

2.4 Function list

Function	Description	Control mode
Pulse train input position control (PTI)	Implements accurate positioning through two pulse train input channels: 5 V differential or 24 V single end signal. In addition, it supports S-curve position smoothing function	PTI
Internal position control (IPos)	Implements accurate positioning through internal position commands (up to eight groups) and allows to specify the acceleration/speed for positioning	IPos
Speed control (S)	Flexibly controls motor speed and direction through external analog speed commands (0 - ±10 VDC) or internal speed commands (up to seven groups)	S
Torque control (T)	Flexibly controls motor output torque through external analog torque commands (0 - ±10 VDC) or internal torque commands. In addition, it supports speed limit function to prevent overspeed when a motor has no loads	T
Compound controls	Supports flexible switches among position control mode, speed control mode, and torque control mode	PTI/S, IPos/S, PTI/T, IPos/T, S/T
Absolute position system	Allows to implement motion control tasks immediately after the servo system with an absolute encoder is powered on, needless of carrying out referencing or zero position operation beforehand	PTI
Gain switching	Switches between gains during motor rotation or stop with an external signal or internal parameters to reduce noise and positioning time, or improve the operation stability of a servo system	PTI, IPos, S
PI/P switching	Switches from PI control to P control with an external signal or internal parameters to suppress overshooting during acceleration or deceleration (for speed control mode) or to suppress undershooting during positioning and reduce the settling time (for position control mode)	PTI, IPos, S
SafeTorque Off (STO)	Safely disconnects torque-generating motor power supply to prevent an unintentional motor restart	PTI, IPos, S, T
Zero speed clamp	Stops motor and clamps the motor shaft when motor speed setpoint is below a parameterized threshold level	S
Modbus communication	Supports the communication between the SINAMICS V90 servo drive and PLC with the standard Modbus communication protocol	PTI, IPos, S, T
One-button auto tuning	Estimates the machine characteristic and sets the closed loop control parameters (position loop gain, speed loop gain, speed integral compensation, filter if necessary, etc.) without any user intervention	PTI, IPos, S, T
Real-time auto tuning	Estimates the machine characteristic and sets the closed loop control parameters (position loop gain, speed loop gain, speed integral compensation, filter if necessary, etc.) continuously in real time without any user intervention	PTI, IPos, S, T
Resonance suppression	Suppresses the mechanical resonance, such as workpiece vibration and base shake	PTI, IPos, S, T
Low frequency vibration suppression	Suppresses the low frequency vibration in the machine system	IPos

Function	Description	Control mode
Speed limit	Limits motor speed through external analog speed limit commands (0 - ± 10 VDC) or internal speed limit commands (up to three groups)	PTI, IPos, S, T
Torque limit	Limits motor torque through external analog torque limit commands (0 - ± 10 VDC) or internal torque limit commands (up to three groups)	PTI, IPos, S
Electronic gear ratio	Defines a multiplier factor for input pulses	PTI, IPos
Basic operator panel (BOP)	Displays servo status on a 6-digit 7-segment display	PTI, IPos, S, T
External braking resistor	An external braking resistor can be used when the internal braking resistor is insufficient for regenerative energy	PTI, IPos, S, T
Digital inputs/outputs (DIs/DOs)	Control signals and status signals can be assigned to eight programmable digital inputs and six digital outputs	PTI, IPos, S, T
Smoothing function	Transforms position characteristics from the pulse train input setpoint into an S-curve profile with a parameterized time constant	PTI
SINAMICS V-ASSISTANT	You can perform parameter settings, test operation, adjustment and other operations with a PC	PTI, IPos, S, T

2.5 Technical data

2.5.1 Technical data - servo drives

General technical data

Parameter	Description	
24 VDC power supply	Voltage (V)	24 (-15% to +20%) ¹⁾
	Maximum current (A)	When using a motor without a brake: 1.6 A When using a motor with a brake: 1.6 A + motor holding brake rated current (See Section "Technical data - servo motors (Page 32)".)
	Ripple caused by the rectifier	$\leq 5\%$
	Safety insulation class	PELV
Overload capability	300%	
Control system	Servo control	
Dynamic brake	Built-in	
Protective functions	Earthing fault protection, output short-circuit protection ²⁾ , overvoltage/undervoltage protection ³⁾ , I ² t inverter, I ² t motor, IGBT overtemperature protection ⁴⁾	
Overvoltage criteria	Category III	
Speed control mode	Speed control range	Analog speed command 1:2000, internal speed command 1:5000
	Analog speed command input	-10 VDC to +10 VDC/rated speed
	Torque limit	Set through a parameter or the analog input command (0 VDC to +10 VDC/max. torque)

2.5 Technical data

Parameter		Description	
Position control mode	Max. input pulse frequency	1 M (differential input), 200 kpps (open collector input)	
	Command pulse multiplying factor	Electronic gear ratio (A/B) A: 1 - 10000, B: 1 - 10000 1/50 <A/B < 200	
	In-position range setting	0 to ±10000 pulse (command pulse unit)	
	Error excessive	±1/10 revolutions	
	Torque limit	Set through a parameter or the analog input command (0 VDC to +10 VDC/max. torque)	
Torque control mode	Analog torque command input	-10 VDC to +10VDC/max. torque (input impedance 10 kΩ to 12 kΩ)	
	Speed limit	Set through a parameter or the analog input command (0 VDC to +10 VDC/max. rated speed)	
Cooling method		Self-cooled	Fan-cooled
Environmental conditions	Surrounding air temperature	Operation	0 °C to 45 °C: without power derating 45 °C to 55 °C: with power derating
		Storage	-40 °C to +70 °C
	Ambient humidity	Operation	< 90% (non-condensing)
		Storage	90% (non-condensing)
	Operating environment		Indoors (without direct sunlight), free from corrosive gas, combustible gas, oil gas, or dust
	Altitude		≤ 1000 m (without power derating)
	Degree of protection		IP 20
	Degree of pollution		Class 2
Vibration	Operation	Shock	Operational area II Peak acceleration: 5 g, 30 ms and 15 g, 11 ms Quantity of shocks: 3 per direction × 6 directions Duration of shock: 1 s
		Vibration	Operational area II 10 Hz to 58 Hz: 0.075 mm deflection 58 Hz to 200 Hz: 1 g vibration
	Product packaging	Vibration	2 Hz to 9 Hz: 3.5 mm deflection 9 Hz to 200 Hz: 1 g vibration Quantity of cycles: 10 per axis Sweep seed: 1 octave/min
Certification	UL, CE, KC, RCM, EAC		

- 1) When SINAMICS V90 works with a motor with a brake, the voltage tolerance of 24 VDC power supply must be -10% to +10% to meet the voltage requirement of the brake.
- 2) Integral solid state short circuit protection does not provide branch circuit protection. Branch circuit protection must be provided in accordance with the National Electrical Code and any additional local codes.
- 3) The V90 200 V servo drive has an overvoltage threshold of 410 VDC and an undervoltage threshold of 150 VDC; the V90 400 V servo drive has an overvoltage threshold of 820 VDC and an undervoltage threshold of 320 VDC.
- 4) SINAMICS V90 does not support motor overtemperature protection. Motor overtemperature is calculated by I²t and protected by the output current from the drive.

Specific technical data

SINAMICS V90 200 V variant

Order No.	6SL3210-5FB...	10-1UA1	10-2UA1	10-4UA1	10-8UA0	11-0UA1	11-5UA0	12-0UA0	
Frame size		FSA	FSA	FSB	FSC	FSD	FSD	FSD	
Rated output current (A)		1.2	1.4	2.6	4.7	6.3	10.6	11.6	
Max. output current (A)		3.6	4.2	7.8	14.1	18.9	31.8	34.8	
Max. supported motor power (kW)		0.1	0.2	0.4	0.75	1.0	1.5	2	
Power loss ¹⁾	Main circuit (W)	8	15	33	48	65	105	113	
	Regenerative resistor (W)	5	5	7	9	13	25	25	
	Control circuit (W)	16	16	16	16	16	18	18	
	Total (W)	29	36	56	73	94	148	156	
Output frequency (Hz)		0 to 330							
Power supply	Voltage/frequency	FSA, FSB and FSC: single phase/three phase 200 VAC to 240 VAC, 50/60 Hz FSD: three phase 200 VAC to 240 VAC, 50/60 Hz							
	Permissible voltage fluctuation	-15% to +10%							
	Permissible frequency fluctuation	-10% to +10%							
	Permissible supply configuration	TN, TT, IT							
	Short-circuit current (SCCR)	Maximum permissible short-circuit current: 65 kA rms Minimum required short-circuit current: 5 kA rms							
	Rated input current (A)	1-phase	2.5	3.0	5.0	10.4	-	-	-
		3-phase	1.5	1.8	3.0	5.0	7.0	11.0	12.0
	Power supply capacity (kVA)	1-phase	0.5	0.7	1.2	2.0	-	-	-
3-phase		0.5	0.7	1.1	1.9	2.7	4.2	4.6	
Inrush current (A)		8.0							
Cooling method		Self-cooled				Fan-cooled			
Mechanical design	Outline dimensions (W x H x D, mm)	45 x 170 x 170		55 x 170 x 170	80 x 170 x 195	95 x 170 x 195			
Weight (kg)		1.1		1.3	1.95	2.35	2.4		

The values here are calculated at rated load.

SINAMICS V90 400 V variant

Order No.	6SL3210-5FE...	10-4UA0	10-8UA0	11-0UA0	11-5UA0	12-0UA0	13-5UA0	15-0UA0	17-0UA0
Frame size		FSAA	FSA	FSA	FSB	FSB	FSC	FSC	FSC
Rated output current (A)		1.2	2.1	3.0	5.3	7.8	11.0	12.6	13.2
Max. output current (A)		3.6	6.3	9.0	13.8	23.4	33.0	37.8	39.6
Max. supported motor power (kW)		0.4	0.75	1.0	1.75	2.5	3.5	5.0	7.0
Power loss ¹⁾	Main circuit (W)	12	29	32	84	96	92	115	138
	Regenerative resistor (W)	17	57	57	131	131	339	339	339
	Control circuit (W)	32	32	35	35	35	36	36	36
	Total (W)	61	118	124	250	262	467	490	513
Output frequency (Hz)		0 to 330							

2.5 Technical data

Order No.	6SL3210-5FE...	10-4UA0	10- 8UA0	11-0UA0	11-5UA0	12- 0UA0	13-5UA0	15-0UA0	17-0UA0
Frame size		FSAA	FSA	FSA	FSB	FSB	FSC	FSC	FSC
Power supply	Voltage/frequency	3-phase 380 VAC to 480 VAC, 50/60 Hz							
	Permissible voltage fluctuation	-15% to +10%							
	Permissible frequency fluctuation	-10% to +10%							
	Permissible supply configuration	TN, TT, IT							
	Short-circuit current (SCCR)	Maximum permissible short-circuit current: 65 kA rms Minimum required short-circuit current: 5 kA rms							
	Rated input current (A)	1.5	2.6	3.8	6.6	9.8	13.8	15.8	16.5
	Power supply capacity (kVA)	1.7	3.0	4.3	7.6	11.1	15.7	18.0	18.9
Inrush current (A)	8.0	8.0	8.0	4.0	4.0	2.5	2.5	2.5	
Cooling method		Self-cooled			Fan-cooled				
Mechanical design	Outline dimensions (W x H x D, mm)	60 x 180 x 200	80 x 180 x 200		100 x 180 x 220		140 x 260 x 240		
Weight (kg)		1.800	2.500	2.510	3.055	3.130	6.515	6.615	6.615

The values here are calculated at rated load.

2.5.2 Technical data - servo motors

General technical data

Parameter	Description
Type of motor	Permanent-magnet synchronous motor
Cooling	Self-cooled
Relative humidity [RH]	90% (non-condensing at 30°C)
Installation altitude [m]	≤ 1000 (without power derating)
Thermal class	B
Vibration severity grade	A (according to IEC 60034-14)
Shock resistance [m/s ²]	25 (continuous in axial direction); 50 (continuous in radial direction); 250 (in a short time of 6 ms)
Bearing lifetime [h]	> 20000 ¹⁾
Paint finish	Black
Protection degree of shaft	IP 65, with shaft oil seal
Type of construction	IM B5, IM V1, and IM V3
Positive rotation	Clockwise (default setting in servo drives)
Certification	CE, EAC

¹⁾ This lifetime is only for reference. When a motor keeps running at rated speed under rated load, replace its bearing after 20,000 to 30,000 hours of service time. Even if the time is not reached, the bearing must be replaced when unusual noise, vibration, or faults are found.

Specific technical data

SIMOTICS S-1FL6, low inertia servo motor

Article No.	1FL60...	22	24	32	34	42	44	52	54
Rated power [kW]		0.05	0.1	0.2	0.4	0.75	1	1.5	2
Rated torque [Nm]		0.16	0.32	0.64	1.27	2.39	3.18	4.78	6.37
Maximum torque [Nm]		0.48	0.96	1.91	3.82	7.2	9.54	14.3	19.1
Rated speed [rpm]		3000							
Maximum speed [rpm]		5000							
Rated frequency [Hz]		200							
Rated current [A]		1.2	1.2	1.4	2.6	4.7	6.3	10.6	11.6
Maximum current [A]		3.6	3.6	4.2	7.8	14.2	18.9	31.8	34.8
Moment of inertia [10^{-4} kgm ²]		0.031	0.052	0.214	0.351	0.897	1.15	2.04	2.62
Moment of inertia (with brake) [10^{-4} kgm ²]		0.038	0.059	0.245	0.381	1.06	1.31	2.24	2.82
Recommended load to motor inertia ratio		Max. 30x				Max. 20x		Max. 15x	
Operating temperature [°C]		1FL602□, 1FL603□ and 1FL604□: 0 to 40 (without power derating) 1FL605□: 0 to 30 (without power derating) ¹⁾							
Storage temperature [°C]		-20 to +65							
Maximum noise level [dB]		60							
Holding brake	Rated voltage (V)	24 ± 10%							
	Rated current (A)	0.25		0.3		0.35		0.57	
	Holding brake torque [Nm]	0.32		1.27		3.18		6.37	
	Maximum brake opening time [ms]	35		75		105		90	
	Maximum brake closing time [ms]	10		10		15		35	
	Maximum number of emergency stops	2000 ²⁾							
Oil seal lifetime [h]		3000 to 5000							
Encoder lifetime [h]		> 20000 ³⁾							
Protection degree of motor body		IP 65							
Protection degree of cable end connector		IP20						-	
Weight [kg]	With brake	0.7	0.9	1.5	1.9	3.7	4.2	6.8/7.0 ⁴⁾	8.0/8.2 ⁴⁾
	Without brake	0.5	0.6	1.0	1.5	2.8	3.4	5.4/5.5 ⁴⁾	6.6/6.7 ⁴⁾

¹⁾ When the surrounding temperature is between 30 °C and 40 °C, the 1FL605 motor will have a power derating of 10%.

²⁾ Restricted emergency stop operation is permissible. Up to 2000 braking operations for the motors of 0.05 kW to 1 kW, and 200 braking operations for the motors of 1.5 kW to 2 kW can be executed with 300% rotor moment of inertia as external moment of inertia from a speed of 3000 rpm without the brake being subject to an inadmissible amount of wear.

³⁾ This lifetime is only for reference. When a motor keeps running at 80% rated value and the surrounding temperature is 30 °C, the encoder lifetime can be ensured.

⁴⁾ The former value indicates the data for low inertia motors with straight connectors; the latter value indicates the data for low inertia motors with angular connectors.

Note

The data of rated torque, rated power, maximum torque in the above table allows a tolerance of 10%.

SIMOTICS S-1FL6, high inertia servo motor

Article No.	1FL60...	42	44	61	62	64	66	67	90	92	94	96	
Rated power [kW]		0.40	0.75	0.75	1.00	1.50	1.75	2.00	2.5	3.5	5.0	7.0 ¹⁾	
Rated torque [Nm]		1.27	2.39	3.58	4.78	7.16	8.36	9.55	11.9	16.7	23.9	33.4	
Maximum torque [Nm]		3.8	7.2	10.7	14.3	21.5	25.1	28.7	35.7	50.0	70.0	90.0	
Rated speed [rpm]		3000			2000				2000				
Maximum speed [rpm]		4000			3000				3000		2500	2000	
Rated frequency [Hz]		200			133				133				
Rated current [A]		1.2	2.1	2.5	3.0	4.6	5.3	5.9	7.8	11.0	12.6	13.2	
Maximum current [A]		3.6	6.3	7.5	9.0	13.8	15.9	17.7	23.4	33.0	36.9	35.6	
Moment of inertia [10 ⁻⁴ kgm ²]		2.7	5.2	8.0	15.3/ 11.7 ²⁾	15.3	22.6	29.9	47.4	69.1	90.8	134.3	
Moment of inertia (with brake) [10 ⁻⁴ kgm ²]		3.2	5.7	9.1	16.4/ 13.5 ²⁾	16.4	23.7	31.0	56.3	77.9	99.7	143.2	
Recommended load to motor inertia ratio		Max. 10x			Max. 5x				Max. 5x				
Operating temperature [°C]		0 to 40 (without power derating)											
Storage temperature [°C]		-20 to +65											
Maximum noise level [dB]		65			70				70				
Holding brake	Rated voltage (V)	24 ± 10%											
	Rated current (A)	0.88			1.44				1.88				
	Holding brake torque [Nm]	3.5			12				30				
	Maximum brake opening time [ms]	60			180				220				
	Maximum brake closing time [ms]	45			60				115				
	Maximum number of emergency stops	2000 ³⁾											
Oil seal lifetime [h]		5000											
Encoder lifetime [h]		> 20000 ⁴⁾											
Degree of protection		IP65, with shaft oil seal											
Weight of incremental encoder motor [kg]	With brake ²⁾	4.6/ 4.8	6.4/ 6.6	8.6/ 8.8	11.3/ 10.1	11.3/ 11.5	14.0/ 14.2	16.6/ 16.8	21.3/ 21.5	25.7/ 25.9	30.3/ 30.5	39.1/ 39.3	
	Without brake ²⁾	3.3/ 3.4	5.1/ 5.2	5.6/ 5.7	8.3/ 7.0	8.3/ 8.4	11.0/ 11.1	13.6/ 13.7	15.3/ 15.4	19.7/ 19.8	24.3/ 24.4	33.2/ 33.3	

Article No.	1FL60...	42	44	61	62	64	66	67	90	92	94	96
Weight of absolute encoder motor [kg]	With brake ²⁾	4.4/ 4.5	6.2/ 6.3	8.3/ 8.4	11.0/ 9.7	11.0/ 11.1	13.6/ 13.7	16.3/ 16.4	20.9/ 21.0	25.3/ 25.4	29.9/ 30.0	38.7/ 38.8
	Without brake ²⁾	3.1/ 3.2	4.9/ 5.0	5.3/ 5.4	8.0/ 6.7	8.0/ 8.1	10.7/ 10.8	13.3/ 13.4	14.8/ 14.9	19.3/ 19.4	23.9/ 24.0	32.7/ 32.8

- 1) When the surrounding temperature is higher than 30 °C, the 1FL6096 motors with brake will have a power derating of 10%.
- 2) The former value indicates the data for high inertia motors with straight connectors; the latter value indicates the data for high inertia motors with angular connectors.
- 3) Restricted emergency stop operation is permissible. Up to 2000 braking operations can be executed with 300% rotor moment of inertia as external moment of inertia from a speed of 3000 rpm without the brake being subject to an inadmissible amount of wear.
- 4) This lifetime is only for reference. When a motor keeps running at 80% rated value and the surrounding temperature is 30 °C, the encoder lifetime can be ensured.

Note

The data of rated torque, rated power, and maximum torque in the above table allows a tolerance of 10%.

Power derating

For deviating conditions (surrounding temperature > 40 °C or installation altitude > 1000 m above sea level) the permissible torque/power must be determined from the following table. Surrounding temperatures and installation altitudes are rounded off to 5 °C and 500 m respectively.

Power derating as a function of the installation altitude and ambient temperature

Installation altitude above sea level (m)	Surrounding temperature in °C				
	< 30	30 to 40	45	50	55
1000	1.07	1.00	0.96	0.92	0.87
1500	1.04	0.97	0.93	0.89	0.84
2000	1.00	0.94	0.90	0.86	0.82
2500	0.96	0.90	0.86	0.83	0.78
3000	0.92	0.86	0.82	0.79	0.75
3500	0.88	0.82	0.79	0.75	0.71
4000	0.82	0.77	0.74	0.71	0.67

2.5.3 Address of CE-authorized manufacturer

The CE Declaration of Conformity is held on file available to the competent authorities at the following address:

SINAMICS V90 drive

Siemens AG
Digital Factory
Motion Control
Frauenauracher Straße 80
DE-91056 Erlangen
Germany

SIMOTICS S-1FL6 motor

Siemens AG
Digital Factory
Motion Control
Industriestraße 1
DE-97615 Bad Neustadt a. d. Saale
Germany

Mounting

3.1 Mounting the drive

Protection against the spread of fire

The device may be operated only in closed housings or in control cabinets with protective covers that are closed, and when all of the protective devices are used. The installation of the device in a metal control cabinet or the protection with another equivalent measure must prevent the spread of fire and emissions outside the control cabinet.

Protection against condensation or electrically conductive contamination

Protect the device, e.g. by installing it in a control cabinet with degree of protection IP54 according to IEC 60529 or NEMA 12. Further measures may be necessary for particularly critical operating conditions.

If condensation or conductive pollution can be excluded at the installation site, a lower degree of control cabinet protection may be permitted.

	WARNING
Death or severe personal injury from harsh installation environment	
A harsh installation environment will jeopardize personal safety and equipment. Therefore,	
<ul style="list-style-type: none"> • Do not install the drive and the motor in an area subject to inflammables or combustibles, water or corrosion hazards. • Do not install the drive and the motor in an area where it is likely to be exposed to constant vibrations or physical shocks. • Do not keep the drive exposed to strong electro-magnetic interference. 	



	CAUTION
Risk of injury due to touching hot surfaces	
There is a risk of injury if you touch the hot surfaces, because surfaces of the drive can reach a high temperature during operation and for a short time after switching-off.	
<ul style="list-style-type: none"> • Avoid coming into direct contact with the drive surface. 	

For mounting conditions, see Technical data - servo drives (Page 29).

The SINAMICS V90 200 V variant servo drives with rated power of 400 W and 750 W support vertical mounting and horizontal mounting. Other drives support vertical mounting only.

Mount the drive in a shielded cabinet by observing the mounting orientation and clearance specified in the following illustrations.

Mounting orientation

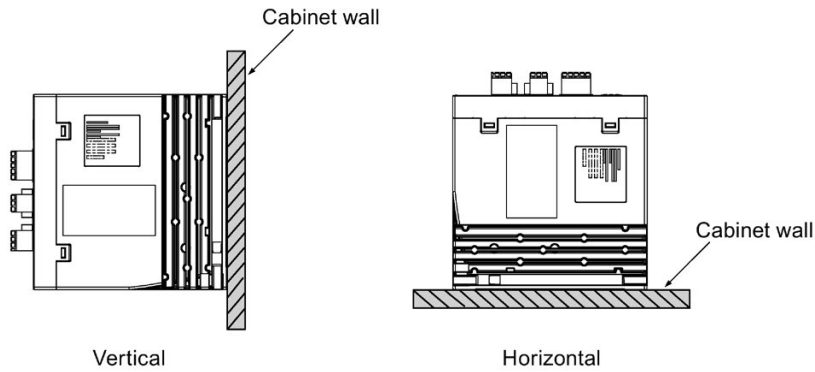

NOTICE

Overheating due to inadmissible mounting orientation

If you use an inadmissible mounting orientation, the drives can overheat and therefore be damaged.

- Always observe the mounting orientation required in the instruction.

Mounting clearance

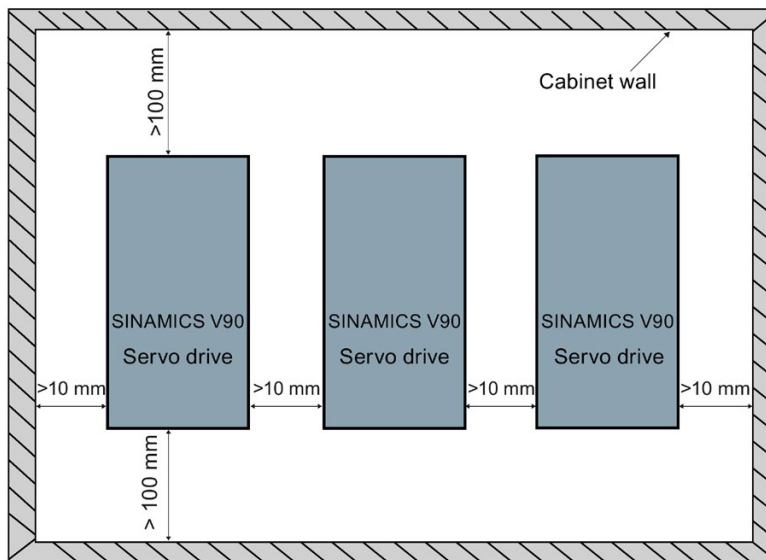

Note

When mounting the drive horizontally, you need to make sure the distance between the drive front panel and the top cabinet wall is longer than 100 mm.

Note

The drive must be derated to 80% when one of the following conditions is satisfied:

- The surrounding temperature is 0 °C to 45 °C, and the mounting clearance is less than 10 mm. In this case, the minimum mounting clearance should not be less than 5 mm.
- The surrounding temperature is 45 °C to 55 °C. In this case, the minimum mounting clearance should not be less than 20 mm.

Note

When mounting the drive in the cabinet, you need to consider the temperature change of the cooling air. The rapid temperature change of the cooling air is forbidden.

Drill patterns and outline dimensions

SINAMICS V90 200 V variant (unit: mm)

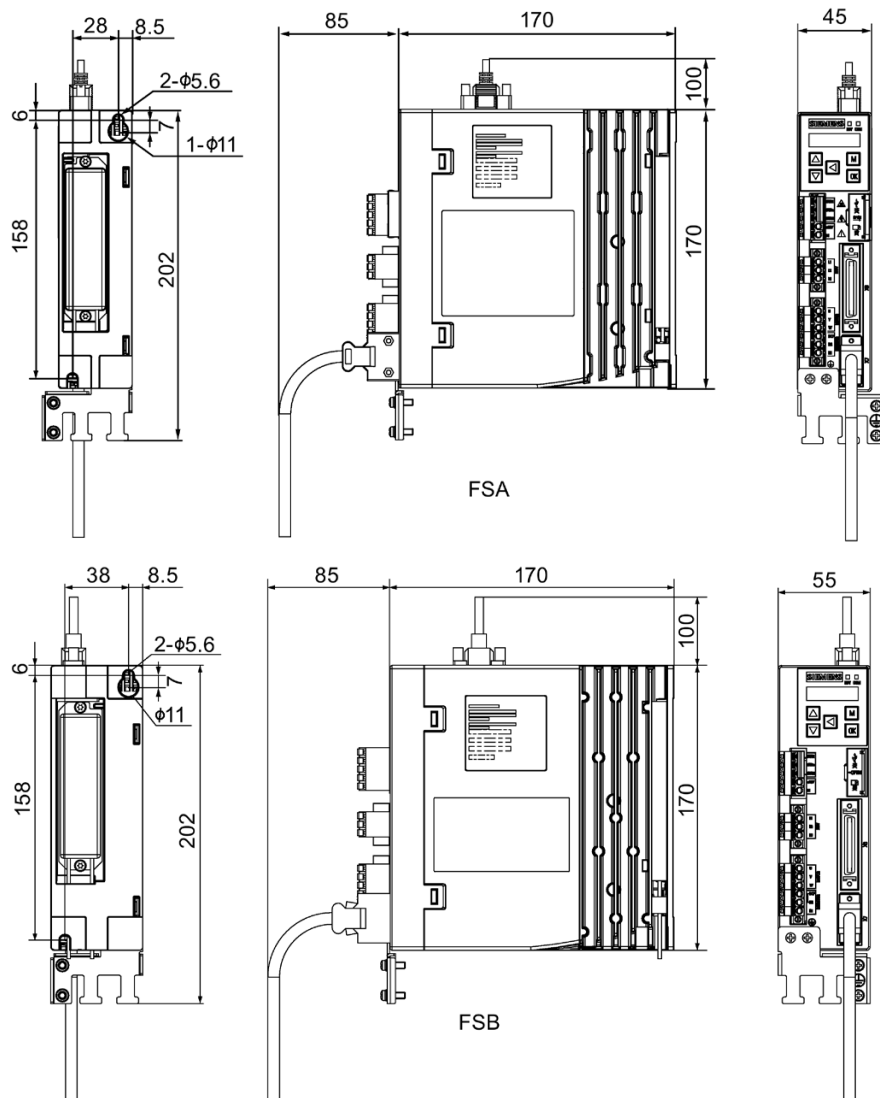

3.1 Mounting the drive

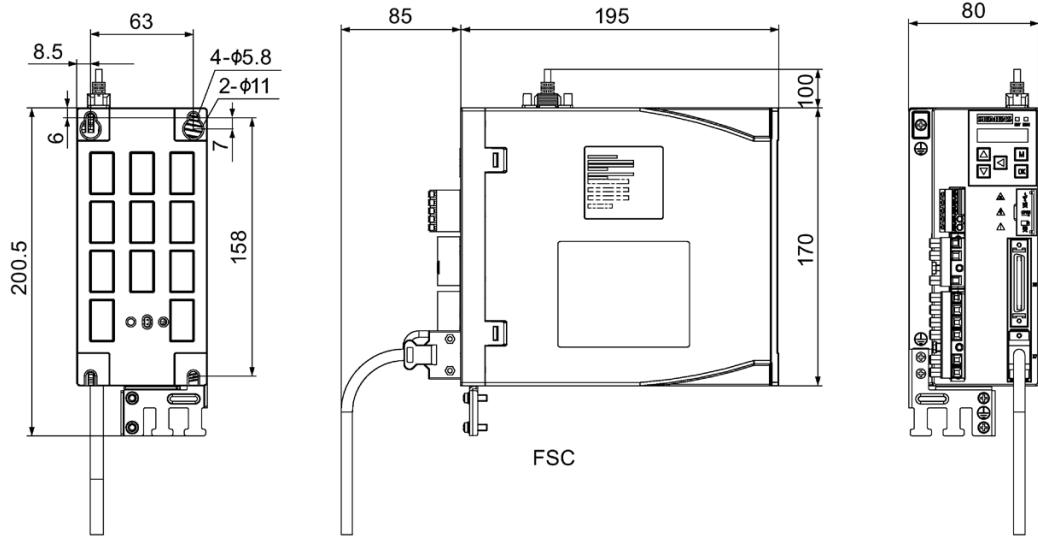

FSC

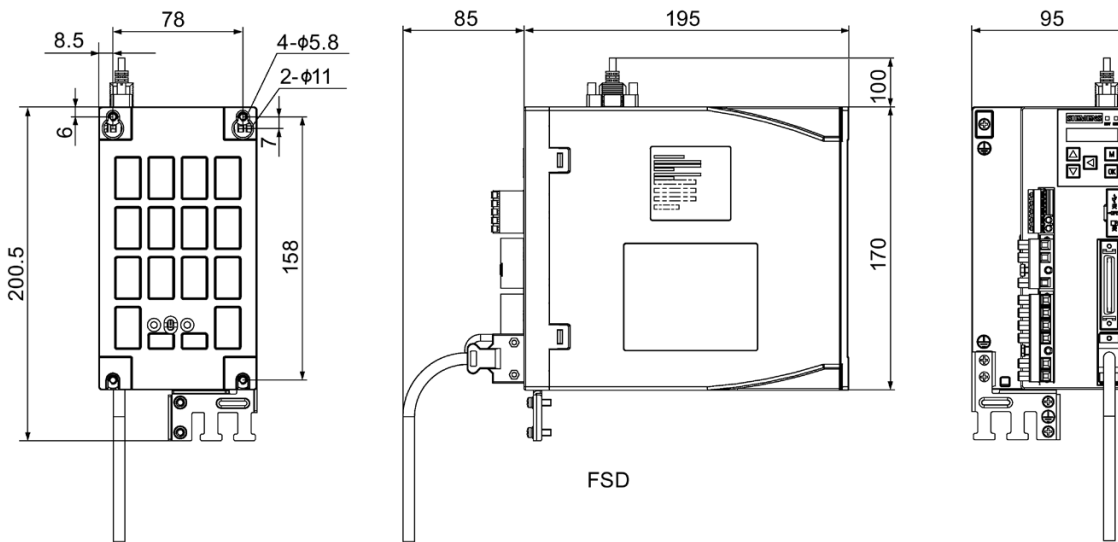

FSD

SINAMICS V90 400 V variant (unit: mm)

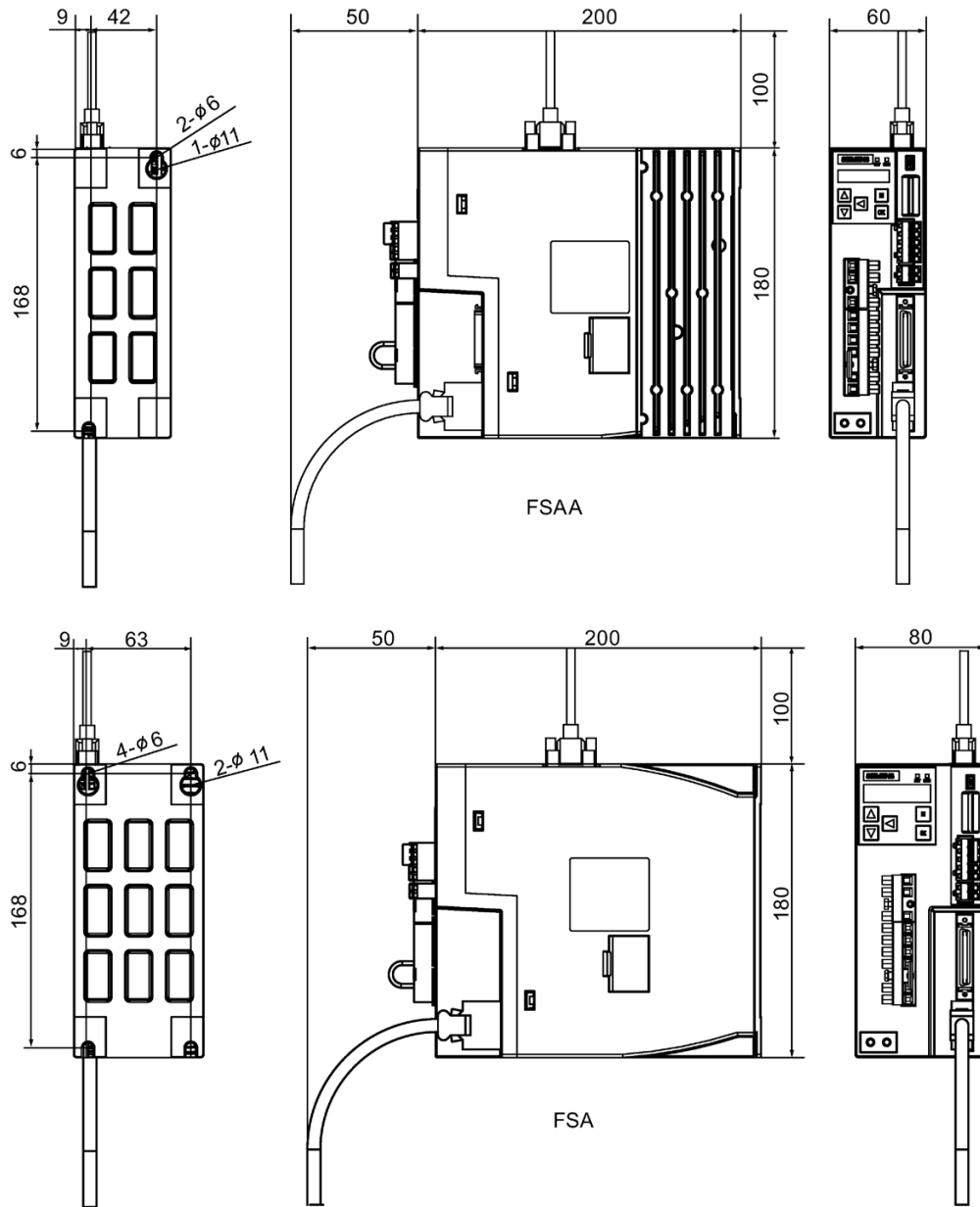

3.1 Mounting the drive

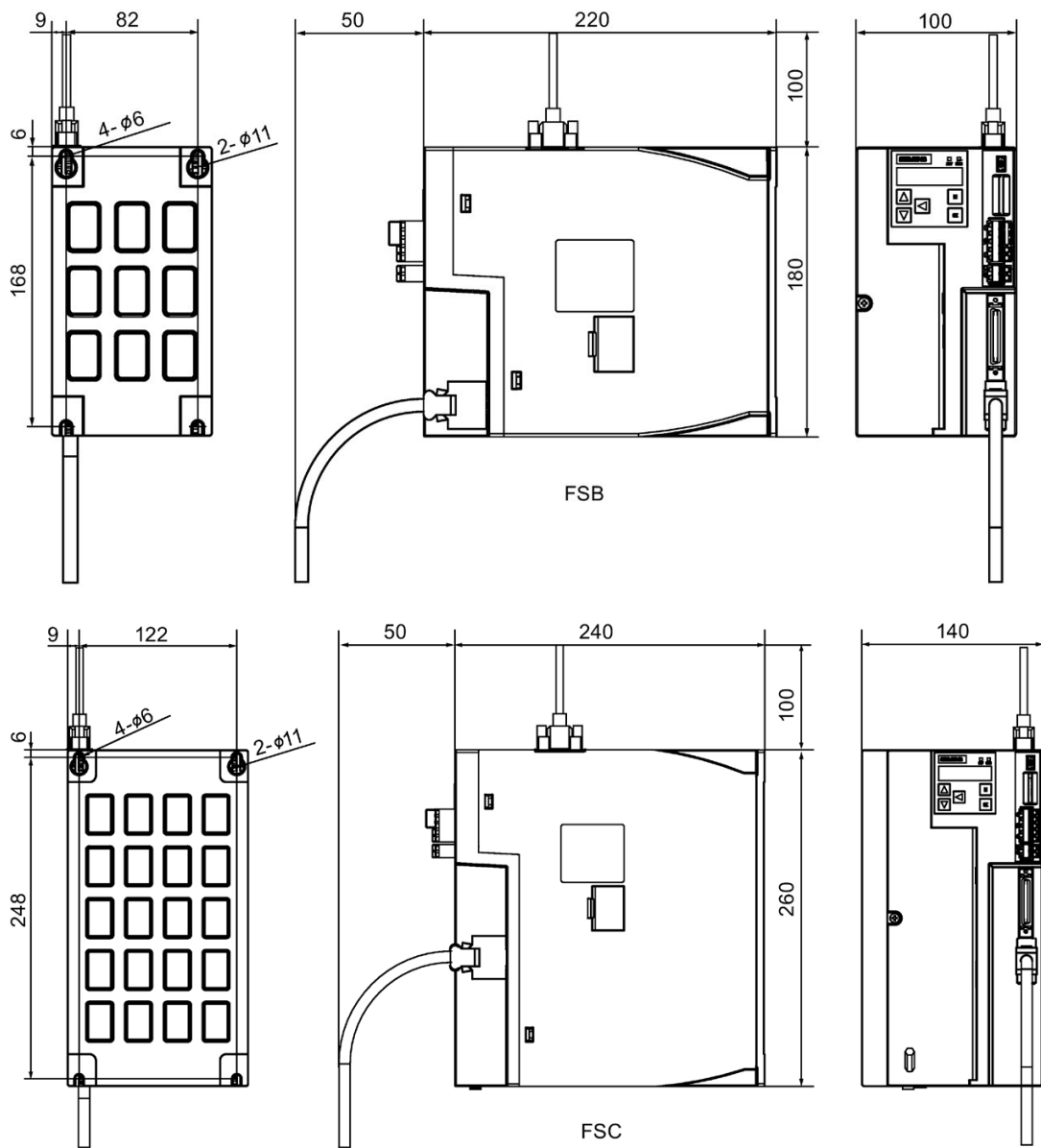

Mounting the drive

For V90 200 V variant, use two M5 screws to mount the FSA and FSB drives and four M5 screws to mount the FSC, and FSD drives.

For V90 400 V variant, use two M5 screws to mount the FSAA drive and four M5 screws to mount the FSA, FSB, and FSC drives.

The recommended tightening torque is 2.0 Nm.

Note**EMC instructions**

- To comply with the EMC standards, all cables connected with the SINAMICS V90 system must be shielded cables, which include cables from the line supply to the line filter and from the line filter to the SINAMICS V90 drive.
 - Route signal cables and power cables separately in different cable conduits. The signal cables shall be at least 10 cm away from the power cables.
 - The SINAMICS V90 drives have been tested in accordance with the emission requirements of the category of C2 (domestic) environment. The conductive emissions and radiated emissions are in compliance with the standard of EN 55011 and reached Class A.
 - This device is designed for operation in the second environment (industrial area) and may not be used in the first environment (residential area) unless the appropriate noise suppression measures have been adopted.
 - For a radiated emission test, an external AC filter (between the mains supply and the drive) will be used to meet the EMC requirement and the drive will be installed inside the shielded metallic chamber, other parts of the motion control system (including the PLC, DC power supply, spindle drive, motor) will be put inside the shielded chamber.
 - For a conductive emission test, an external AC filter (between the mains supply and the drive) will be used to meet the EMC requirement.
 - For the radiated emission and conductive emission test, the length of the line supply cable between the line filter and the drive must be shorter than 1 m.
 - The harmonic current value of SINAMICS V90 exceed the class A limit of IEC 61000-3-2, but the SINAMICS V90 system installed within the Category C2 First Environment require supply authority acceptance for connection to the public low-voltage power supply network. Please contact your local supply network provider.
-

NOTICE**Malfunction caused by radio devices or mobile phones**

When radio devices or mobile phones are used in the immediate vicinity of the drives (less than 20 cm), the drives can be disturbed, which can cause the drives to malfunction. This may impair the functional safety of drives and can therefore put people in danger or lead to property damage.

- If you come closer than around 20 cm to the drives, switch off any radios or mobile phones.
-

Note**Screw tightening**

Make sure you fix the screw to the terminal door of the drive after you have completed the installation work.

Note

For the installation altitude lower than or equal to 2000 m above sea level, it is permissible to connect the drive to any of the line supplies that are specified for it. For the installation altitude higher than 2000 m and lower than 5000 m above sea level, you must connect the drive to any of the specified line supplies either via an isolating transformer or with a grounded neutral point.

3.2 Mounting the motor

NOTICE

Damage to the encoder due to shocking

Shocks at the motor shaft end can cause encoder damage.



- Do not exert any shock at the shaft end.

For mounting conditions, see Technical data - servo motors (Page 32).

Mounting orientation

SIMOTICS S-1FL6 supports flange mounting only and three types of constructions, so it can be installed in three orientations as shown in the following figure.

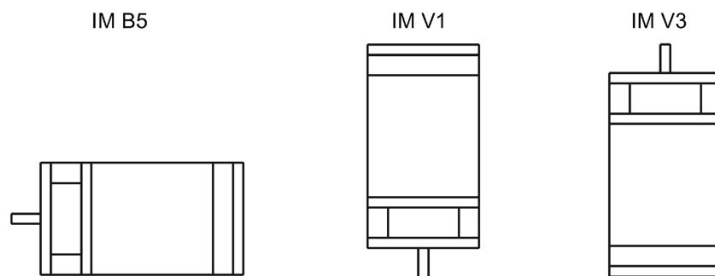

Note

When configuring the IM V3 type of construction, pay particular attention to the permissible axial force (weight force of the drive elements) and the necessary degree of protection.

Motor dimensions (unit: mm)

Low inertia servo motor, shaft height: 20 mm, 30 mm, and 40 mm

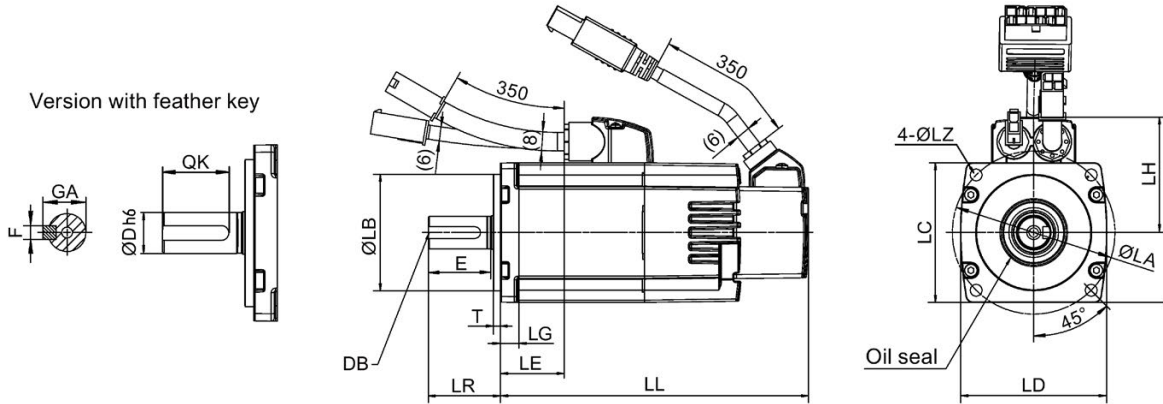

Low inertia servo motor, shaft height: 50 mm, with straight connectors

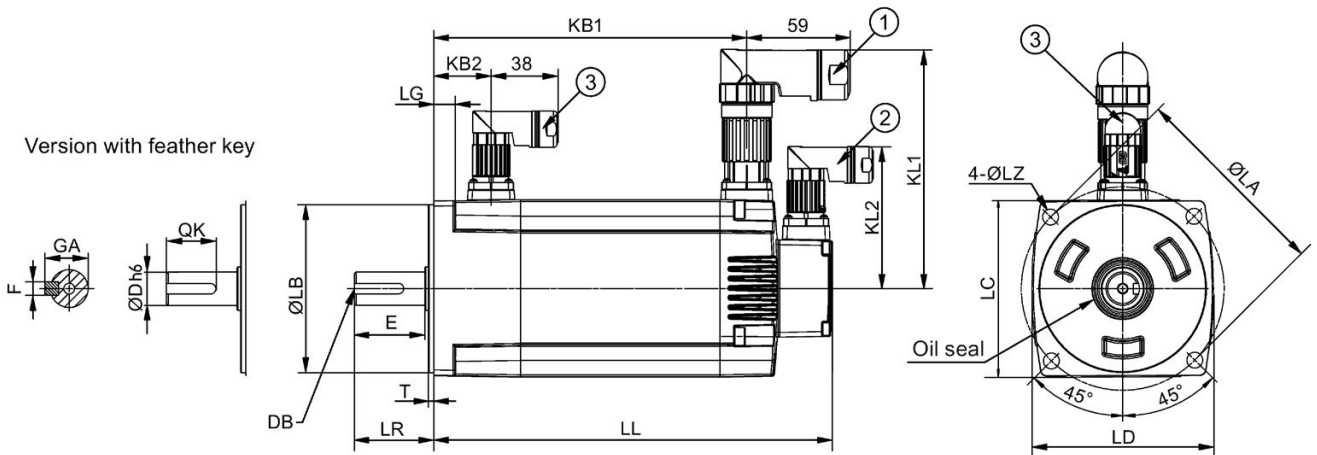

Low inertia servo motor, shaft height: 50 mm, with angular connectors

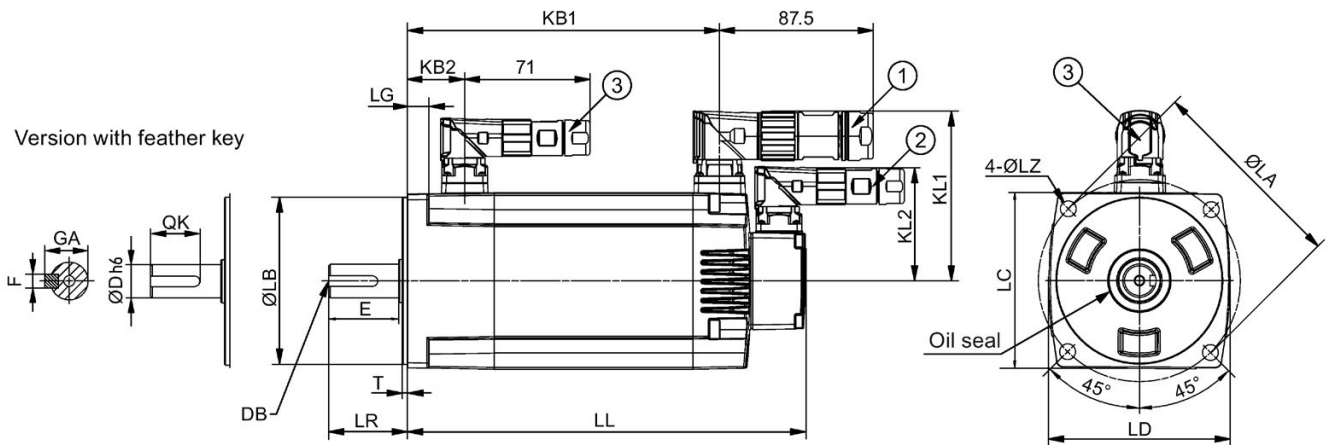

3.2 Mounting the motor

Type	1FL60...	22	24	32	34	42	44	52	54
Shaft height		20		30		40		50	
LC		40		60		80		100	
LD		42		63		82.6		103	
LA		46		70		90		115	
LZ		4.5		5.5		7		9	
LB		30 - 0.02		50 - 0.03		70 - 0.03		95 - 0.03	
LH		40		50		60		-	
LE		15	35	27	52	40	60	-	
LR		25		31		35		45	
T		2.5 - 0.2		3 - 0.2		3 - 0.3		3 - 0.3	
LG		6		8		8		12	
D		8 - 0.009		14 - 0.011		19 - 0.013		19 - 0.013	
DB		M3 × 8		M4 × 15		M6 × 16		M6 × 16	
E		22		26		30		40	
QK		17.5		22.5		28		28	
GA		9.2		16		21.5		21.5	
F		3		5		6		6	
Without brake	LL	86	106	98	123	139	158.8	192	216
	KB1	-	-	-	-	-	-	143.5	167.5
With brake	LL	119	139	132.5	157.5	178.3	198.1	226	250
	KB1	-	-	-	-	-	-	177.5	201.5
	KB2	-	-	-	-	-	-	32.5	32.5
KL1		-	-	-	-	-	-	135	135
KL2		-	-	-	-	-	-	80	80

- ①–Power cable connector, ②–Incremental/absolute encoder cable connector, ③–Brake cable connector. These connectors should be ordered separately. For more information about the order information of the connectors, see the SINAMICS V90, SIMOTICS S-1FL6 Operating Instructions.
- For the low inertia motor with shaft-height of 50 mm, the boundary dimensions of encoder connector–② and brake connector–③ are the same.
- For the low inertia motor with shaft-height of 20 mm, only two screws are needed to mount the flange.

High inertia servo motor with straight connectors, with the incremental encoder

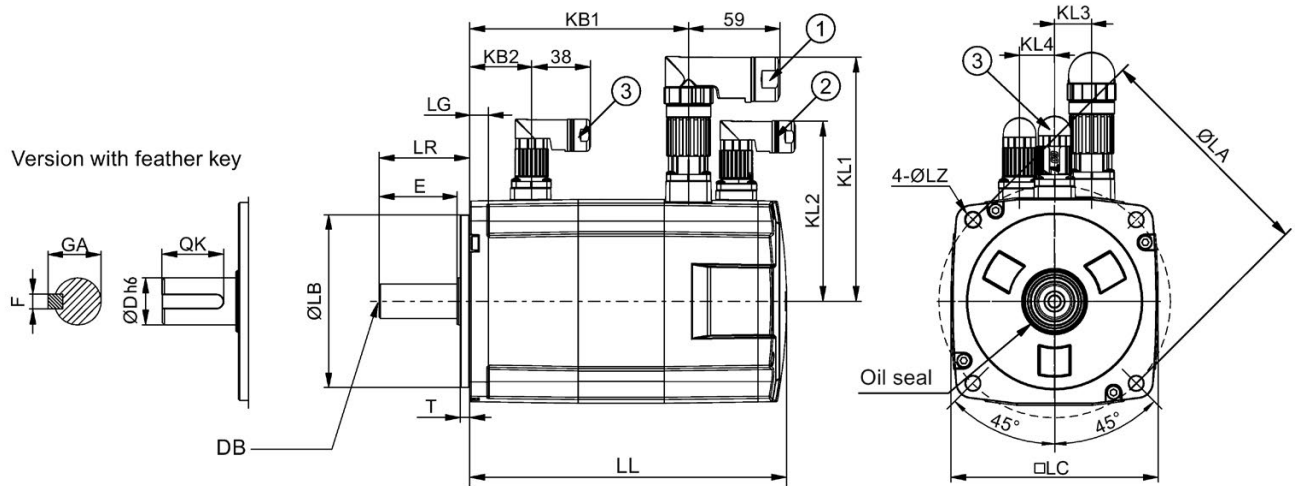

High inertia servo motor with angular connectors, with the incremental encoder

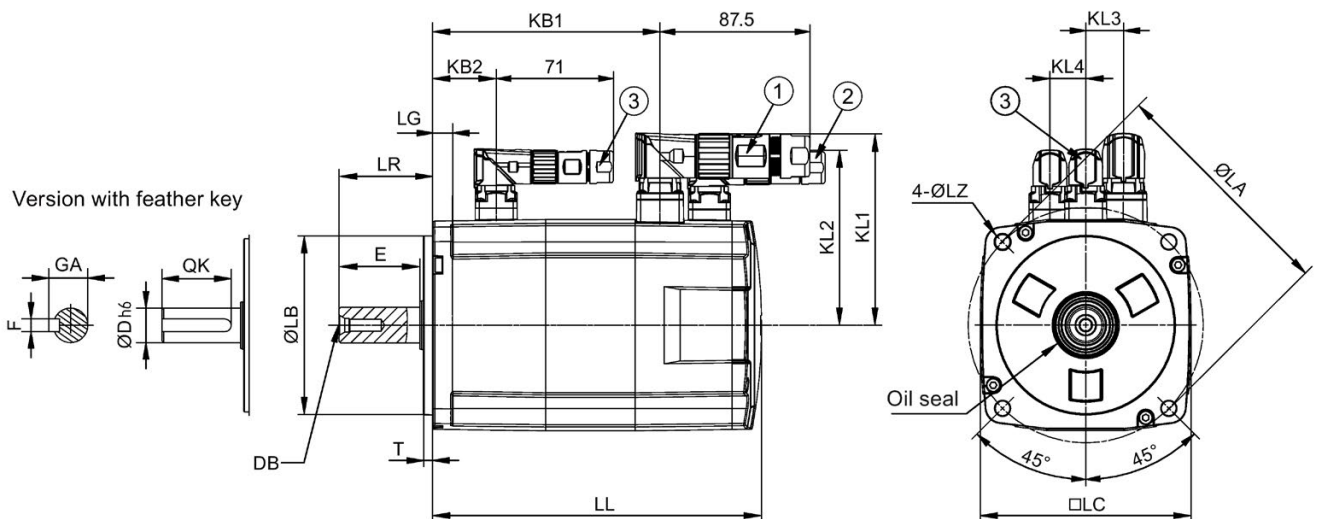

Type	1FL60...	42	44	61	62	64	66	67	90	92	94	96
Shaft height		45		65					90			
LC		90		130					180			
LA		100		145					200			
LZ		7		9					13.5			
LB		80 - 0.03		110 - 0.035					114.3 - 0.035			
LR		35		58					80			
T		4 - 0.3		6 - 0.3					3 - 0.3			
LG		10		12					18			
D		19 - 0.013		22 - 0.013					35 - 0.016			
DB		M6 x 16		M8 x 16					M12 x 25			
E		30		50					75			

3.2 Mounting the motor

Type	1FL60...	42	44	61	62	64	66	67	90	92	94	96
QK		25		44				60				
GA		21.5		25				38				
F		6 - 0.03		8 - 0.036				10 - 0.036				
Without brake	LL	154.5	201.5	148	181/ 164.5 ¹⁾	181	214	247	189.5	211.5	237.5	289.5
	KB1	93.5	140.5	85.5	118.5	118.5	151.5	184.5	140	162	188	240
	KB2	-		-				-				
With brake	LL	201	248	202.5	235.5/ 219 ¹⁾	235.5	268.5	301.5	255	281	307	359
	KB1	140	187	140	173	173	206	239	206	232	258	310
	KB2	31.5		39.5				44.5				
With straight connectors	KL1	136		158				184				
	KL2	92		115				149				
	KL3	13		23				34				
	KL4	14		22				34				
With angular connectors	KL1	96.2		117.5				143				
	KL2	84.6		108				141.1				
	KL3	13		23				34				
	KL4	14		22				34				

- ①–Power cable connector, ②–Incremental encoder cable connector, ③–Brake cable connector. These connectors should be ordered separately. For more information about the order information of the connectors, see the SINAMICS V90, SIMOTICS S-1FL6 Operating Instructions.
- The boundary dimensions of encoder connector–② and brake connector–③ are the same.
- The shaft height 90 mm motor has two M8 screw holes for eyebolts.

1) The former value indicates the dimension for high inertia motors with straight connectors; the latter value indicates the dimension for high inertia motors with angular connectors.

High inertia servo motor with straight connectors, with the absolute encoder

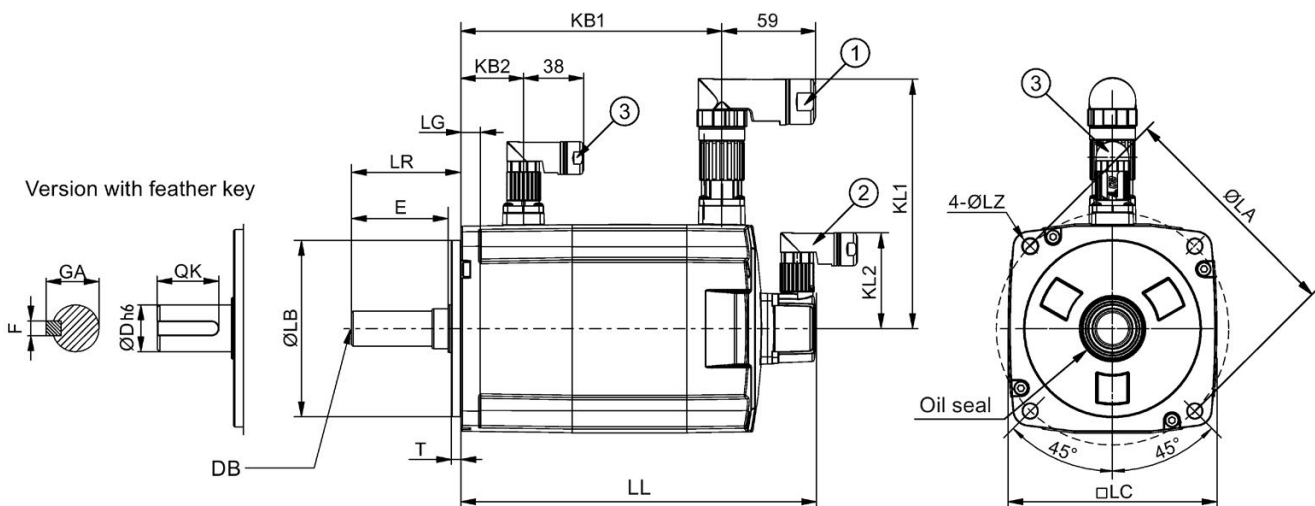

High inertia servo motor with angular connectors, with the absolute encoder

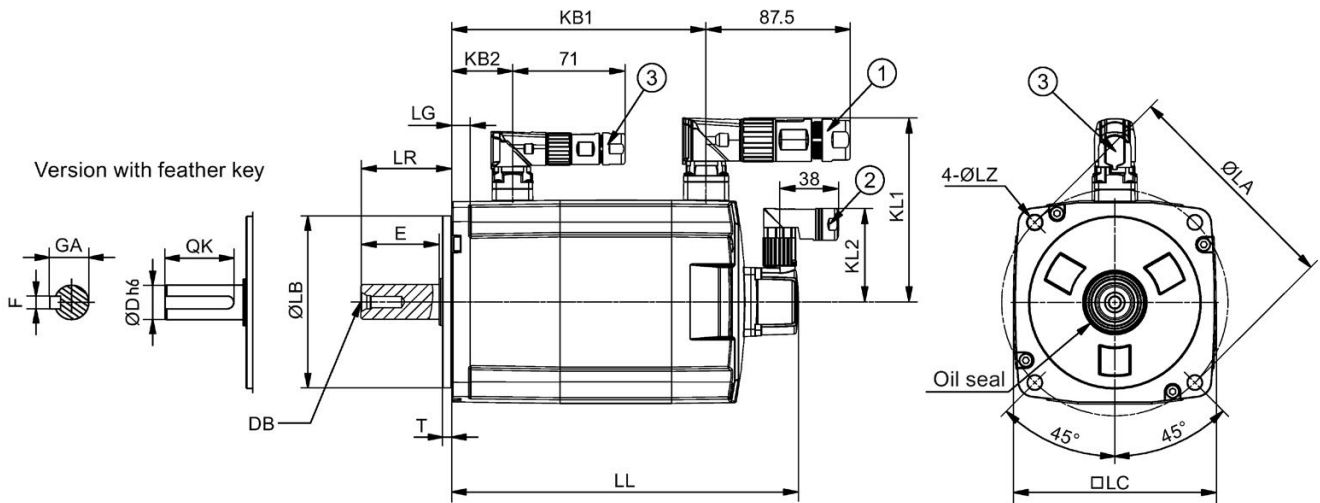

Type	1FL60...	42	44	61	62	64	66	67	90	92	94	96
Shaft height		45		65					90			
LC		90		130					180			
LA		100		145					200			
LZ		7		9					13.5			
LB		80 - 0.03		110 - 0.035					114.3 - 0.035			
LR		35		58					80			
T		4 - 0.3		6 - 0.3					3 - 0.3			
LG		10		12					18			
D		19 - 0.013		22 - 0.013					35 - 0.016			
DB		M6 x 16		M8 x 16					M12 x 25			
E		30		50					75			
QK		25		44					60			
GA		21.5		25					38			
F		6 - 0.03		8 - 0.036					10 - 0.036			
Without brake	LL	157	204	151	184/ 167.5 ¹⁾	184	217	250	197	223	249	301
	KB1	100	147	92	125	125	158	191	135	161	187	239
	KB2	-	-	-	-	-	-	-	-	-	-	-
With brake	LL	203.5	250.5	205.5	238.5/ 222 ¹⁾	238.5	271.5	304.5	263	289	315	367
	KB1	147	194	147	180	180	213	246	201	227	253	305
	KB2	31.5	39.5	39.5	44.5	44.5	44.5	44.5	44.5	44.5	44.5	44.5
With straight connectors	KL1	136	158	158	184	184	184	184	184	184	184	184
	KL2	60	60	60	60	60	60	60	60	60	60	60

3.2 Mounting the motor

Type	1FL60...	42	44	61	62	64	66	67	90	92	94	96
With angular connectors	KL1	96.2		117.5					143			
	KL2	60		60					60			

- ①-Power cable connector, ②-Absolute encoder cable connector, ③-Brake cable connector. These connectors should be ordered separately. For more information about the order information of the connectors, see the SINAMICS V90, SIMOTICS S-1FL6 Operating Instructions.
- The shaft height 90 mm motor has two M8 screw holes for eyebolts.

1) The former value indicates the dimension for high inertia motors with straight connectors; the latter value indicates the dimension for high inertia motors with angular connectors.

Mounting the motor

⚠ WARNING

Personal injury and material damage due to motor falling down

Some motors especially the 1FL609□ are heavy. Motor falling down can cause serious personal injury or material damage.

- The excessive weight of the motor should be considered and any necessary assistance required for mounting should be sought.

NOTICE

Damage to the motor due to liquid entering

If the liquid enters the motor, the motor may be damaged

- During motor installation or operation, make sure that no liquid (water, oil, etc.) can penetrate into the motor.
- When installing the motor horizontally, make sure that the cable outlet faces downward to protect the motor from ingress of oil or water.

NOTICE

Damage to the absolute encoder due to the magnetic interference from the magnetic field

The magnetic interference from the magnetic field can cause a damage to the absolute encoder.

- To avoid magnetic interference to the absolute encoder, keep the servo motor with an absolute encoder at least 15 mm away from the devices that produce a magnetic field stronger than 10 mT.

Note

Using the eyebolts

The 1FL609□ motor (90 mm shaft height) has two M8 screw holes for screwing in two eyebolts. Lift the 1FL609□ motor only at the eyebolts.

Eyebolts that have been screwed in must be either tightened or removed after mounting.

Install the motor onto a steel flange with four screws as shown in the following figure:

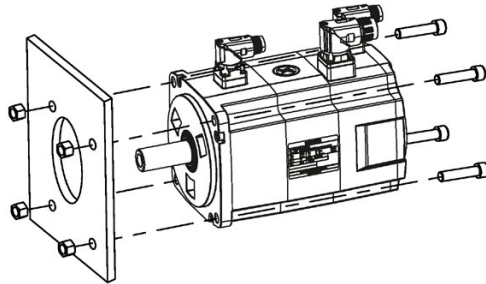

Motor	Screw	Recommended flange size	Tightening torque	Flange material
Low inertia motors				
1FL602□	2 x M4	120 x 100 x 40 (mm)	2.4 Nm	Steel
1FL603□	4 x M5	120 x 100 x 40 (mm)	4.7 Nm	
1FL604□	4 x M6	120 x 100 x 40 (mm)	8 Nm	
1FL605□	4 x M8	120 x 100 x 40 (mm)	20 Nm	
High inertia motors				
1FL604□	4 x M6	270 x 270 x 10 (mm)	8 Nm	Steel
1FL606□	4 x M8	390 x 390 x 15 (mm)	20 Nm	
1FL609□	4 x M12	420 x 420 x 20 (mm)	85 Nm	

Motor heating conditions

The rated motor specifications are continuous allowable values at a surrounding air temperature of 40 °C when the motor is installed with a steel flange. When the motor is mounted on a small surface, the motor temperature may rise considerably because of the limited heat radiating abilities of the surface. Make sure you use a suitable flange according to Siemens recommended flange sizes.

Note

The actual temperature rise depends on how the flange (motor mounting section) is fixed on the installation surface, what material is used for the motor mounting section, and motor speed. Always check the actual motor temperature.

Connecting

4.1 System connection

The following illustrations show examples of the SINAMICS V90 servo system connection:

SINAMICS V90 200 V variant

The connection for FSB when used on the single phase power network:

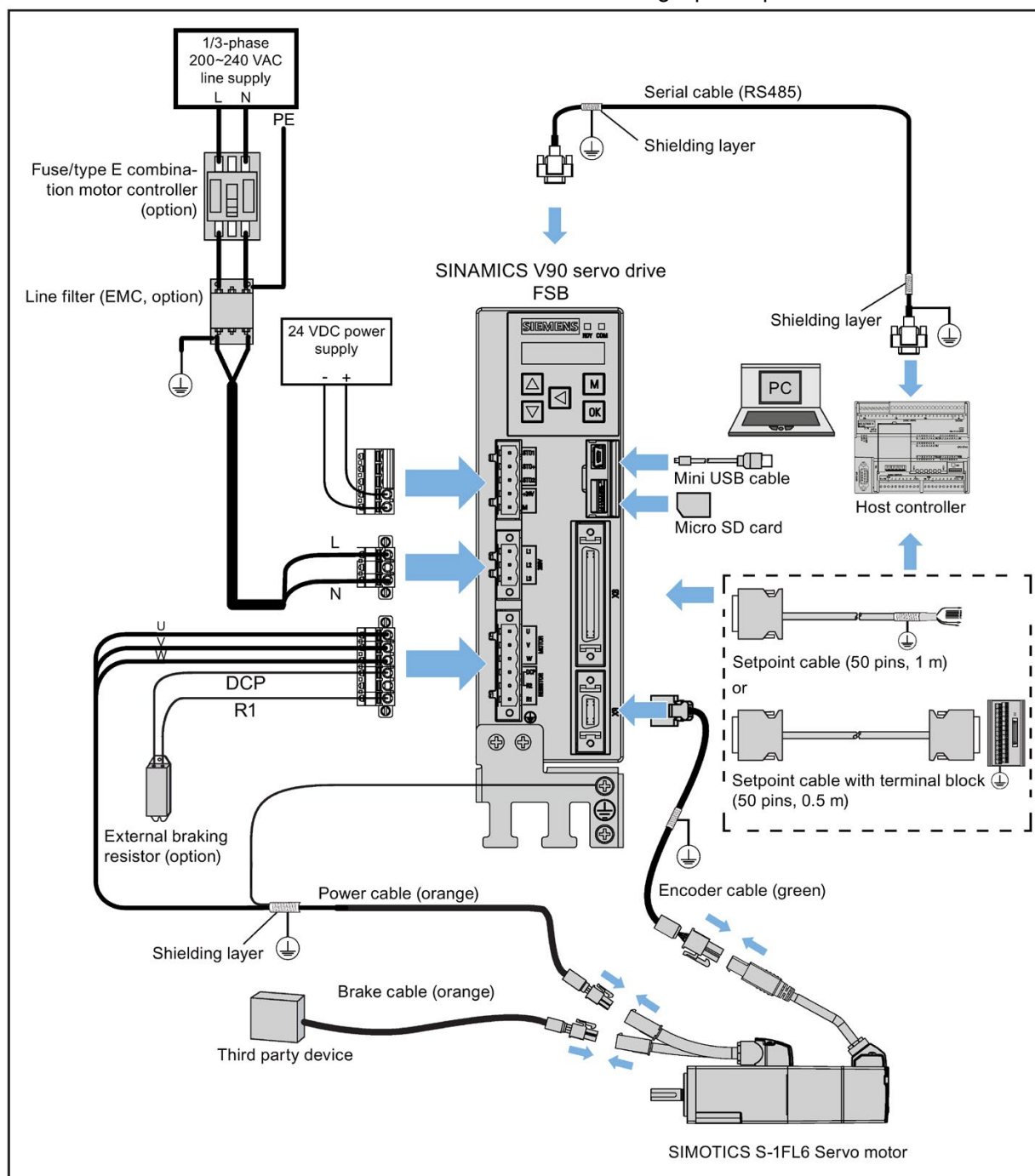

The connection for FSD when used on the three phase power network:

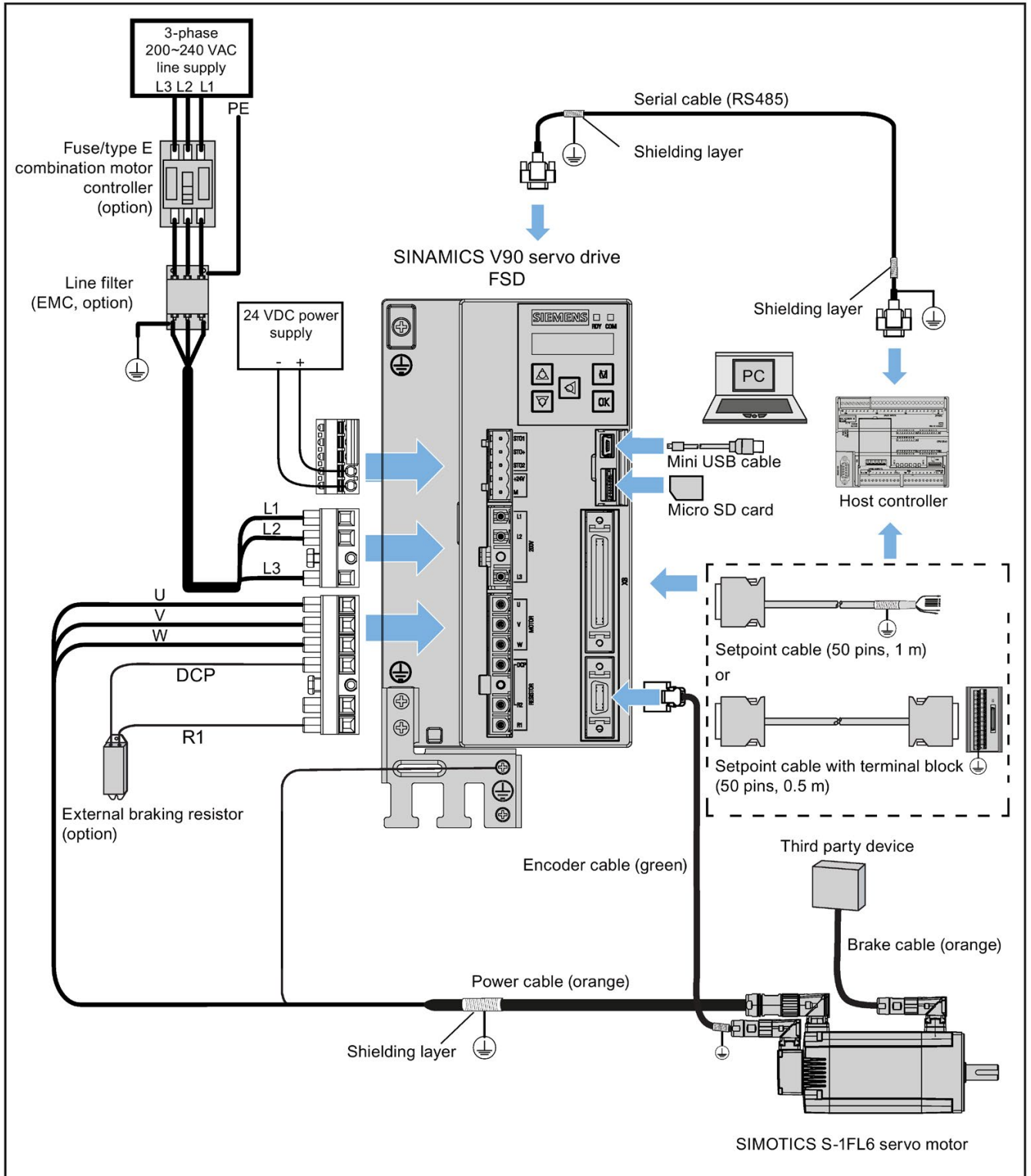

SINAMICS V90 400 V variant

The connection for FSB when used on the three phase power network:

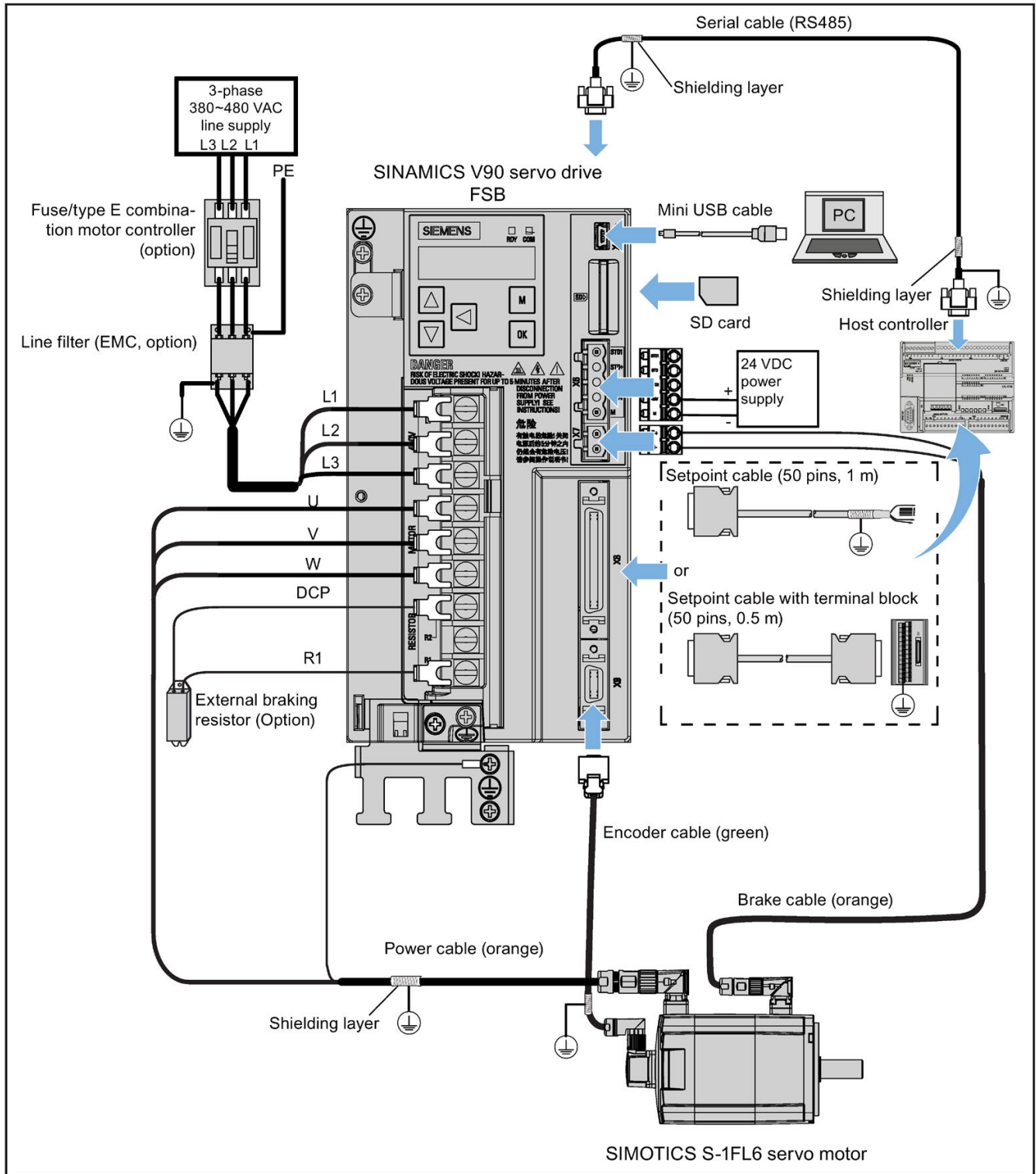



! WARNING

Danger to life when PE connectors are touched

When the equipment is working, hazardous touch current can be present at the PE connectors; if touched, this can result in death or severe personal injury.

- Do not touch the PE connector during operation or within a certain period since power disconnection.



! WARNING

Personal injury and damage to property from improper connections

Improper connections have high risks of electrical shock and short circuit, which will jeopardize personal safety and equipment.

- The drive must be directly connected with the motor. It is not permissible to connect a capacitor, inductor or filter between them.
- Make sure that all connections are correct and reliable, the drive and the motor are well grounded.
- The line supply voltage must be within the allowable range (refer to the drive rating plate). Never connect the line supply cable to the motor terminals U, V, W or connect the motor power cable to the line input terminals L1, L2, L3.
- Never wire up the U, V, W terminals in an interchanged phase sequence.
- If the CE marking for cables is mandatory in some cases, the motor power cable, line supply cable and brake cable used must all be shielded cables.
- For terminal box connection, make sure that the clearances in air between non-insulated live parts are at least 5.5 mm.
- Cables connected may not come into contact with rotating mechanical parts.

! CAUTION

Personal injury and damage to property from inadequate protection

Inadequate protection may cause minor personal injury or damage to property.

- Route a second PE conductor with the cross section of the supply system lead in parallel to the protective earth via separate terminals or use a copper protective earth conductor with a cross section of 10 mm².
- Terminals for equipotential bondings that exist in addition to terminals for PE conductors must not be used for looping-through the PE conductors.
- To ensure protective separation, an isolating transformer must be used for the 200 VAC/380 VAC line supply system.

NOTICE

Drive damage caused by short-circuiting between the shielding wire and the unused pin on the setpoint connector

The shielding wire may inadvertently be short-circuited to the unused pin on the to-be-assembled setpoint connector. This can cause damage to the drive.

- Exercise caution when connecting the shielding cable to the setpoint connector.
- For more information about the assembly method of the connector, see Section "Assembly of cable terminals on the drive side" in the SINAMICS V90, SIMOTICS S-1FL6 Operating Instructions.

Note

Interruptions of the internal protective bonding of the equipment caused by cable movement

The interruptions of the internal protective bonding of the equipment may be caused by cable movement such as dragging cables.

- Do not drag cables when in operation.
- Make sure that you have performed appropriate protective measures for the protective bonding when moving cables.

Note

Failure to meet the EMC requirements resulting from failure to observe the wiring instruction

Failure to meet the EMC requirements because you do not observe the wiring instruction.

- In order to meet **EMC** requirements, all cables must be shielded cables.
- Make sure that you connect the cable shields of shielded twisted-pair cables to the shielding plate or the hose clamp of the servo drive.

Note

Low Voltage Directive complied

Our products comply with EN61800-5-1: 2007 standards and Low Voltage Directive (Low Voltage Directive 2006/95/EC).

Note

For low inertia motors with shaft-heights of 20 mm, 30 mm and 40 mm, the encoder cable connectors may only be accessible to electrically skilled personnel.

Note

The mini-USB interface of the SINAMICS V90 is used for fast commissioning and diagnostics with SINAMICS V-ASSISTANT installed in the PC. Do not use it for long monitoring.

Connecting the cable shields with the shielding plate

To achieve EMC-compliant installation of the drive, use the shielding plate that is shipped with the drive to connect the cable shields. See the following example for steps to connect cable shields with the shielding plate:

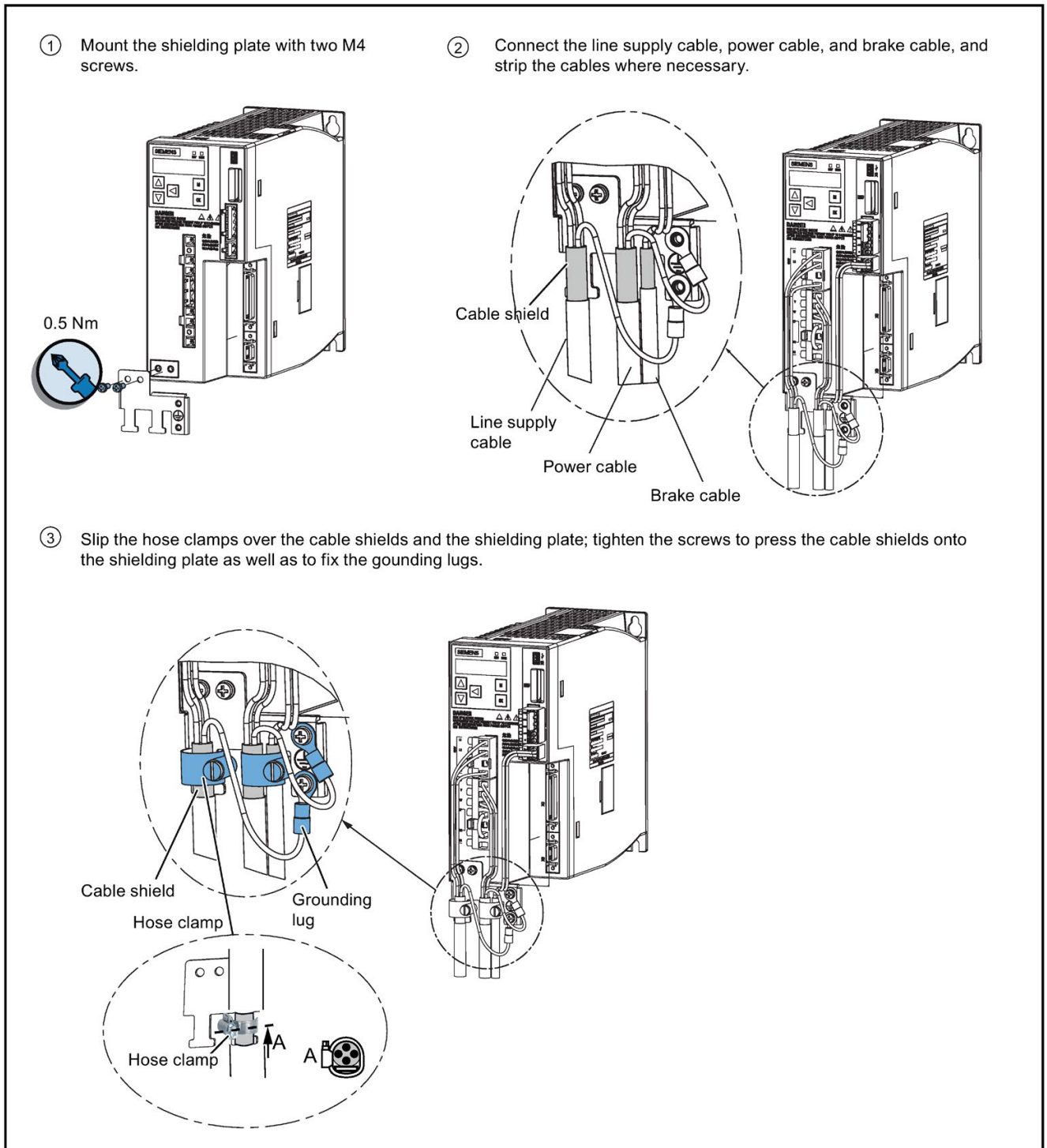



⚠ WARNING	
Risk of electric shock and fire from a network with an excessively high impedance	
Excessively low short-circuit currents can lead to the protective devices not tripping or tripping too late, and so causing electric shock or a fire.	
<ul style="list-style-type: none"> • In the case of a conductor-conductor or conductor-ground short-circuit, ensure that the short-circuit current at the point where the drive is connected to the line supply at least meets the minimum requirements for the response of the protective device used. • You must use an additional residual-current device (RCD) if a conductor-ground short circuit does not reach the short-circuit current required for the protective device to respond. The required short-circuit current can be too low, especially for TT systems. 	



⚠ WARNING	
Risk of electric shock and fire from a network with an impedance that is too low	
Excessively high short-circuit currents can lead to the protective devices not being able to interrupt these short-circuit currents and being destroyed, and so causing electric shock or a fire.	
<ul style="list-style-type: none"> • Ensure that the uninfluenced short-circuit current at the line terminal of the drive does not exceed the breaking capacity (SCCR or I_{cc}) of the protective device used. 	



⚠ WARNING	
Death or severe personal injury from electrical shock	
The earth leakage current for the drive can be greater than AC 3.5 mA, which may cause death or severe personal injury due to electrical shock.	
<ul style="list-style-type: none"> • A fixed earth connection is required to eliminate the dangerous leakage current. In addition, the minimum size of the protective earth conductor shall comply with the local safety regulations for high leakage current equipment. 	

Adjusting cable directions from the motor side

For some low inertia motors and all high inertia motors, you can adjust the direction of the power cable, encoder cable, or brake cable from the motor side to facilitate cable connection.

The following illustrations take high inertia motors with the incremental encoder for example to show how to adjust the cable directions.

Low inertia motors with a shaft height of 50 mm and high inertia motors with straight connectors

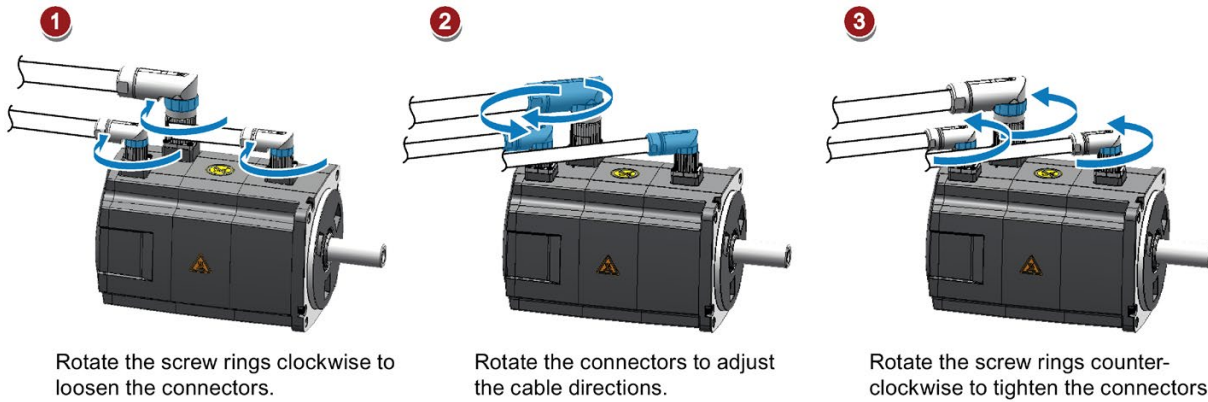

Note

Rotating the connectors

After connecting the cable to the motor, you can rotate the incremental encoder connector within 270° and rotate the absolute encoder connector within 180°. For other connectors, you can rotate them within 360°.

High inertia motors with angular connectors

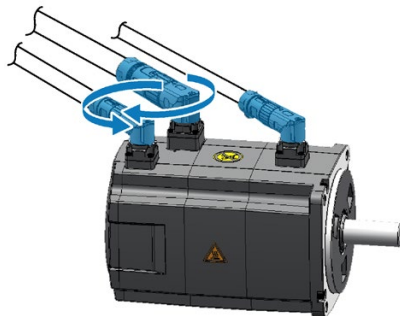

Rotate the connectors to adjust the cable directions.

Note

Rotating the connectors

For motors with angular connectors, you can rotate all the connectors within 310° except for the absolute encoder connector which can be rotated only within 180°.

Note

For an absolute encoder cable on a high inertia motor with angular connectors, adjust its direction just the same as you adjust the cable directions on a high inertia motor with straight connectors mentioned above.

4.2 Main circuit wiring

4.2.1 Line supply - L1, L2, L3

SINAMICS V90 200 V variant

Recommended minimum cable cross-section:

When used on the single phase power network:

FSA: 0.75 mm²

FSB: 0.52 mm²

FSC: 1.31 mm²

When used on the three phase power network:

FSA: 0.75 mm²

FSB: 0.33 mm²

FSC: 0.52 mm²

FSD (1 kW): 0.82 mm²

FSD (1.5 kW to 2 kW): 2.08 mm²

SINAMICS V90 400 V variant

Recommended minimum cable cross-section:

FSAA and FSA: 1.5 mm²

FSB and FSC: 2.5 mm²

Note

For 200 V variant, when using the FSA, FSB and FSC on the single phase power network, you can connect the power supply to any two connectors of L1, L2, and L3.

Assembling the line supply cable terminals

The procedure of assembling a line supply cable terminal is the same as that for a power cable terminal on the drive side.

For more information, see the SINAMICS V90, SIMOTICS S-1FL6 Operating Instructions.

Attaching the line supply cable

CAUTION

Risk of injury due to improper cable connection

When attaching the line supply cable to a line supply connector that has not been fixed on the drive, you can injure your fingers.

- Make sure you first assemble the line supply connector to the drive and tighten the fixing screws on the connector, and then attach the cable to the connector.

200 V variant

- For FSA and FSB

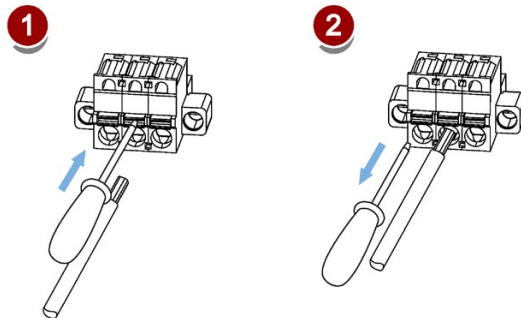

- For FSC and FSD

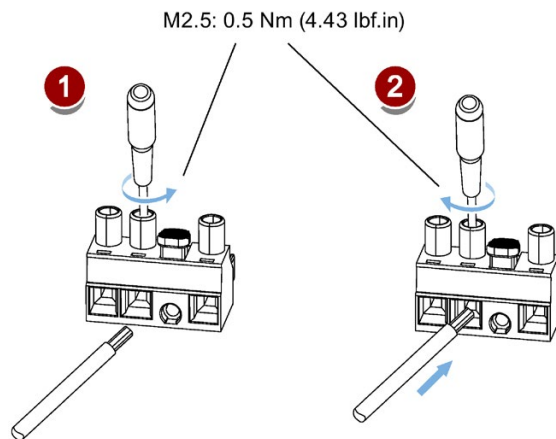

400 V variant

- For FSAA and FSA

You can attach the line supply cable with the same method for 200 V variant drives of frame sizes FSC and FSD.

- For FSB and FSC

The FSB and FSC servo drives are equipped with barrier terminals for line supply connection. You can fix the line supply cable on the servo drives by using the M4 screws with a tightening torque of 2.25 Nm (19.91 lbf.in).

4.2.2 Motor power - U, V, W

Motor output - drive side

SINAMICS V90 200 V variant

Recommended minimum cable cross-section:

FSA and FSB: 0.75 mm²

FSC and FSD (1 kW): 0.75 mm²

FSD (1.5 kW to 2 kW): 2.5 mm²

SINAMICS V90 400 V variant

Recommended minimum cable cross-section:

FSAA and FSA: 1.5 mm²

FSB and FSC: 2.5 mm²

Wiring

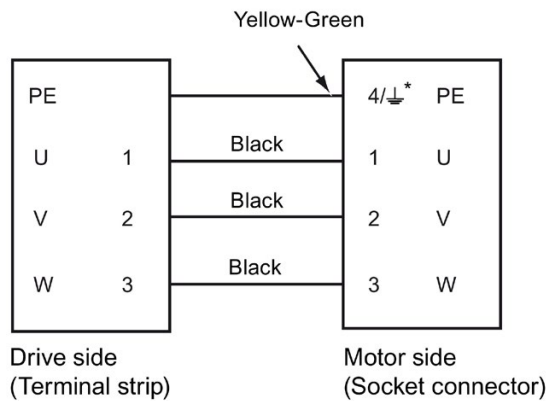

- * 4: high inertia motors with straight connectors and all low inertia motors
- ⊥: high inertia motors with angular connectors

Attaching the motor power cable

 CAUTION
<p>Risk of injury due to improper cable connection</p> <p>When attaching the motor power cable to a motor power connector that has not been fixed on the drive, you can injure your fingers.</p> <ul style="list-style-type: none"> • Make sure you first assemble the motor power connector to the drive and tighten the fixing screw on the connector, and then attach the cable to the connector.

200 V variant

- For FSA and FSB

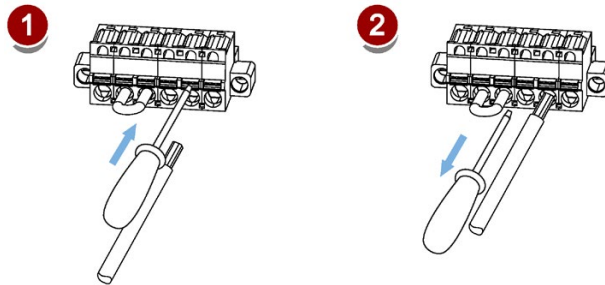

- For FSC and FSD

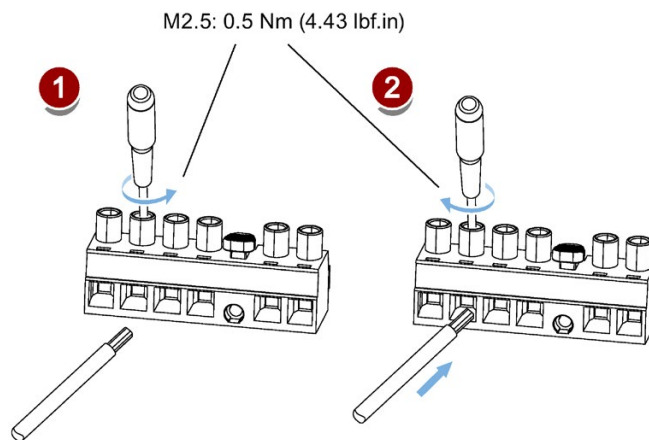

400 V variant

- For FSAA and FSA

You can attach the motor power cable with the same method for 200 V variant drives of frame sizes FSC and FSD.

- For FSB and FSC

The FSB and FSC servo drives are equipped with barrier terminals for motor power connection. You can fix the motor power cable on the servo drives by using the M4 screws with a tightening torque of 2.25 Nm (19.91 lbf.in).

4.3 Control/Status interface - X8

4.3.1 Interface definition

The pins with an asterisk (*) have been redefined in the table below, wherein DO4(+/-) to DO6(+/-) are used for the servo drive to support the wiring of **both** the NPN and the PNP types.

























Note



















The pin definition updates are applicable only when the FS (function state) version is as follows:

- V90 200 V: FS02 and the later
- V90 400 V: FS04 and the later

Refer to the rating plate on the drive housing for the FS version of a SINAMICS V90 servo drive.

Pin No.	Signal	Wire color on the setpoint cable exposed side	Description
<p>Type: 50-pin MDR socket</p>			
Pulse train inputs (PTI)/Pulse train encoder outputs (PTO)			
1, 2, 26, 27: Position setpoint with pulse train input High-speed 5 V differential pulse train input (RS485) Maximum frequency: 1MHz Signal transmission of this channel has better noise immunity			
1	PTIA_D+	Gray-Pink	High-speed 5 V differential pulse train input A (+)
2	PTIA_D-	Red-Blue	High-speed 5 V differential pulse train input A (-)
26	PTIB_D+	White-Black	High-speed 5 V differential pulse train input B (+)
27	PTIB_D-	Brown-Black	High-speed 5 V differential pulse train input B (-)
36, 37, 38, 39: Position setpoint with pulse train input 24 V single end pulse train input Maximum frequency: 200 kHz			
36	PTIA_24P	Green-Blue	24 V pulse train input A, positive
37	PTIA_24M	Yellow-Blue	24 V pulse train input A, ground

Pin No.	Signal	Wire color on the setpoint cable exposed side	Description
38	PTIB_24P	 Green-Black	24 V pulse train input B, positive
39	PTIB_24M	 Yellow-Black	24 V pulse train input B, ground
15, 16, 40, 41: Encoder emulation pulse output with high-speed 5 V differential signals (A+/A-, B+/B-)			
15	PTOA+	 White-Yellow	High-speed 5 V differential pulse train encoder output A (+)
16	PTOA-	 Yellow-Brown	High-speed 5 V differential pulse train encoder output A (-)
40	PTOB+	 Gray-Blue	High-speed 5 V differential pulse train encoder output B (+)
41	PTOB-	 Pink-Blue	High-speed 5 V differential pulse train encoder output B (-)
17, 25 *: Encoder Zero phase pulse output and reference ground (with open collector)			
17	PTOZ (OC)	 White-Gray	Pulse train encoder output Z signal (open collector output)
25 *	PTOZ_M (OC)	 Gray-Green	Pulse train output Z signal reference ground (open collector output)
42, 43: Encoder Zero phase pulse output with high-speed 5 V differential signals			
42	PTOZ+	 Gray-Red	High-speed 5 V differential pulse train encoder output Z (+)
43	PTOZ-	 Pink-Red	High-speed 5 V differential pulse train encoder output Z (-)
24 *: PTO and PTI_D reference ground			
24 *	M	 Brown-Red	PTO and PTI_D reference ground
Digital inputs/outputs			
3	DI_COM	 Green	Common terminal for digital inputs
4	DI_COM	 Yellow	Common terminal for digital inputs
5	DI1	 Gray	Digital input 1
6	DI2	 Pink	Digital input 2
7	DI3	 Blue	Digital input 3
8	DI4	 Red	Digital input 4
9	DI5	 Black	Digital input 5
10	DI6	 Violet	Digital input 6
11	DI7	 White	Digital input 7
12	DI8	 Brown	Digital input 8
13	DI9	 White-Green	Digital input 9
14	DI10	 Brown-Green	Digital input 10
23	Brake	 White-Red	Motor holding brake control signal (for SINAMICS V90 200 V variant only)
28	P24V_DO	 Yellow-Gray	External 24 V supply for digital outputs

Pin No.	Signal	Wire color on the setpoint cable exposed side	Description
29 *	DO4+	 Green	Digital output 4+
30	DO1	 Yellow	Digital output 1
31	DO2	 Gray	Digital output 2
32	DO3	 Pink	Digital output 3
33 *	DO4-	 Pink-Green	Digital output 4-
34 *	DO5+	 Yellow-Pink	Digital output 5+
35 *	DO6+	 Green-Red	Digital output 6+
44 *	DO5-	 Yellow-Red	Digital output 5-
49 *	DO6-	 White	Digital output 6-
50	MEXT_DO	 Brown	External 24 V ground for digital outputs
Analog inputs/outputs			
18	P12AI	 Gray-Brown	12 V power output for analog input
19	AI1+	 White-Pink	Analog input channel 1, positive
20	AI1-	 Pink-Brown	Analog input channel 1, negative
21	AI2+	 White-Blue	Analog input channel 2, positive
22	AI2-	 Brown-Blue	Analog input channel 2, negative
45	AO_M	 Gray-Black	Analog output ground
46	AO1	 Pink-Black	Analog output channel 1
47	AO_M	 Blue-Black	Analog output ground
48	AO2	 Red-Black	Analog output channel 2

Refer to the following table for the original definitions of the above pins with an asterisk (*), wherein DO4 to DO6 are used for the servo drive to support the wiring of **only** the NPN type.

Note

The original pin definitions are applicable only when the FS version is as follows:

- V90 200 V: FS01
- V90 400 V: FS03 and the earlier

Refer to the rating plate on the drive housing for the FS version of a SINAMICS V90 servo drive.

Pin No.	Signal	Description
24	-	Reserved
25	-	Reserved
29	P24V_DO	External 24 V supply for digital outputs
33	DO4	Digital output 4
34	DO5	Digital output 5
35	DO6	Digital output 6
44	-	Reserved
49	MEXT_DO	External 24 V ground for digital outputs

4.3.2 Standard wiring

Pulse train input position control (PTI)

Servo drive

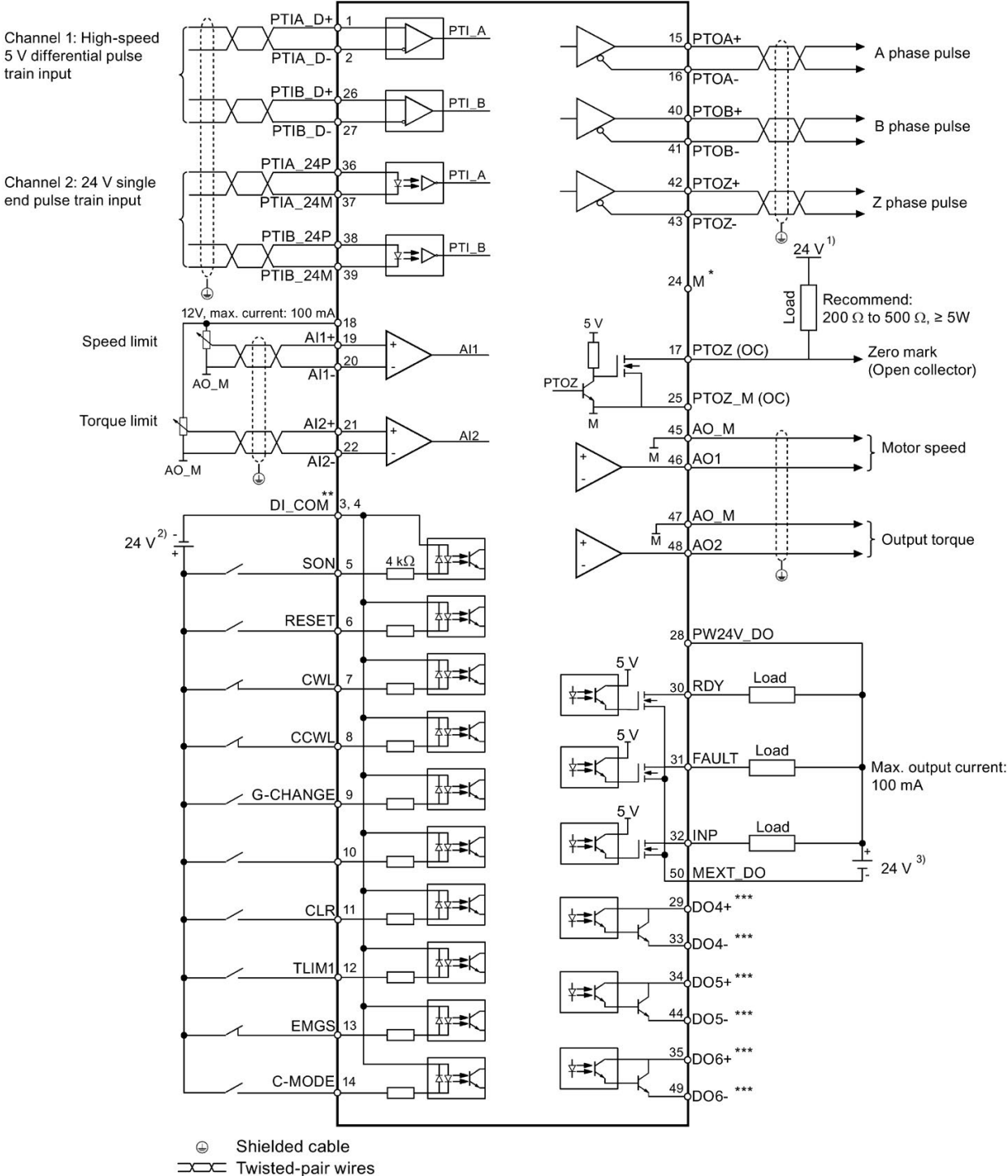

Note
 Only one of the pulse train input channels can be used.

Internal position control (IPos)

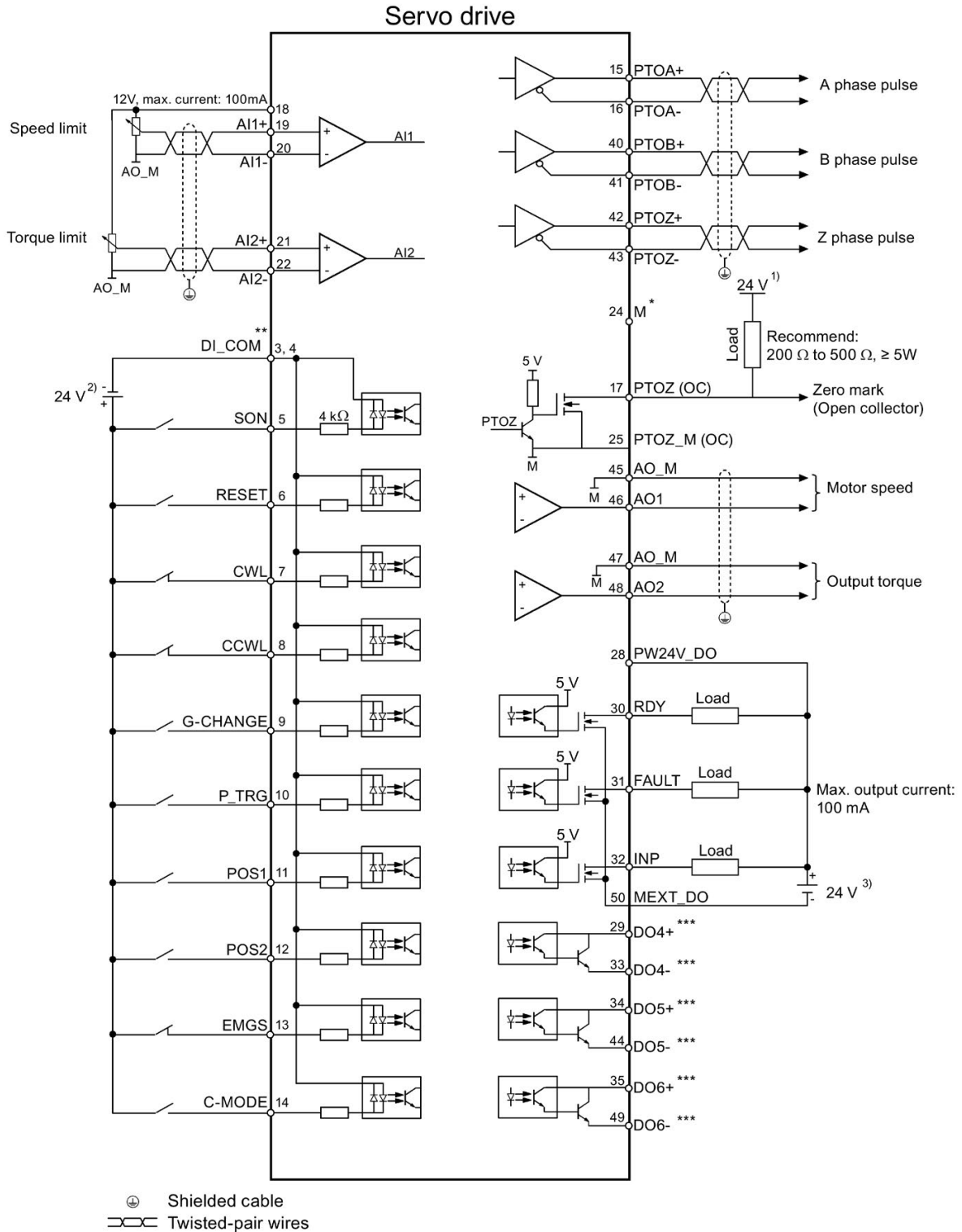

Speed control (S)

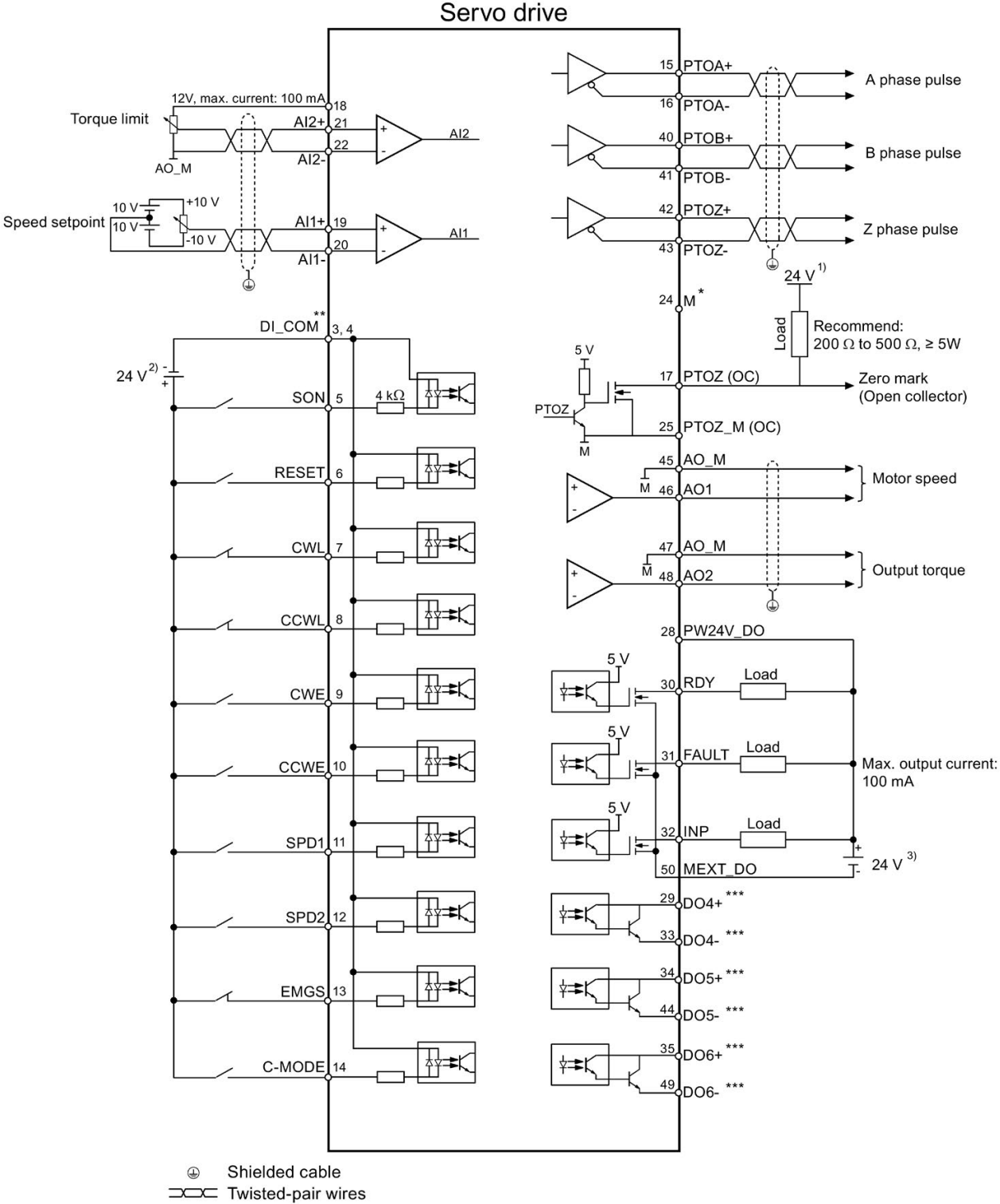

Torque control (T)

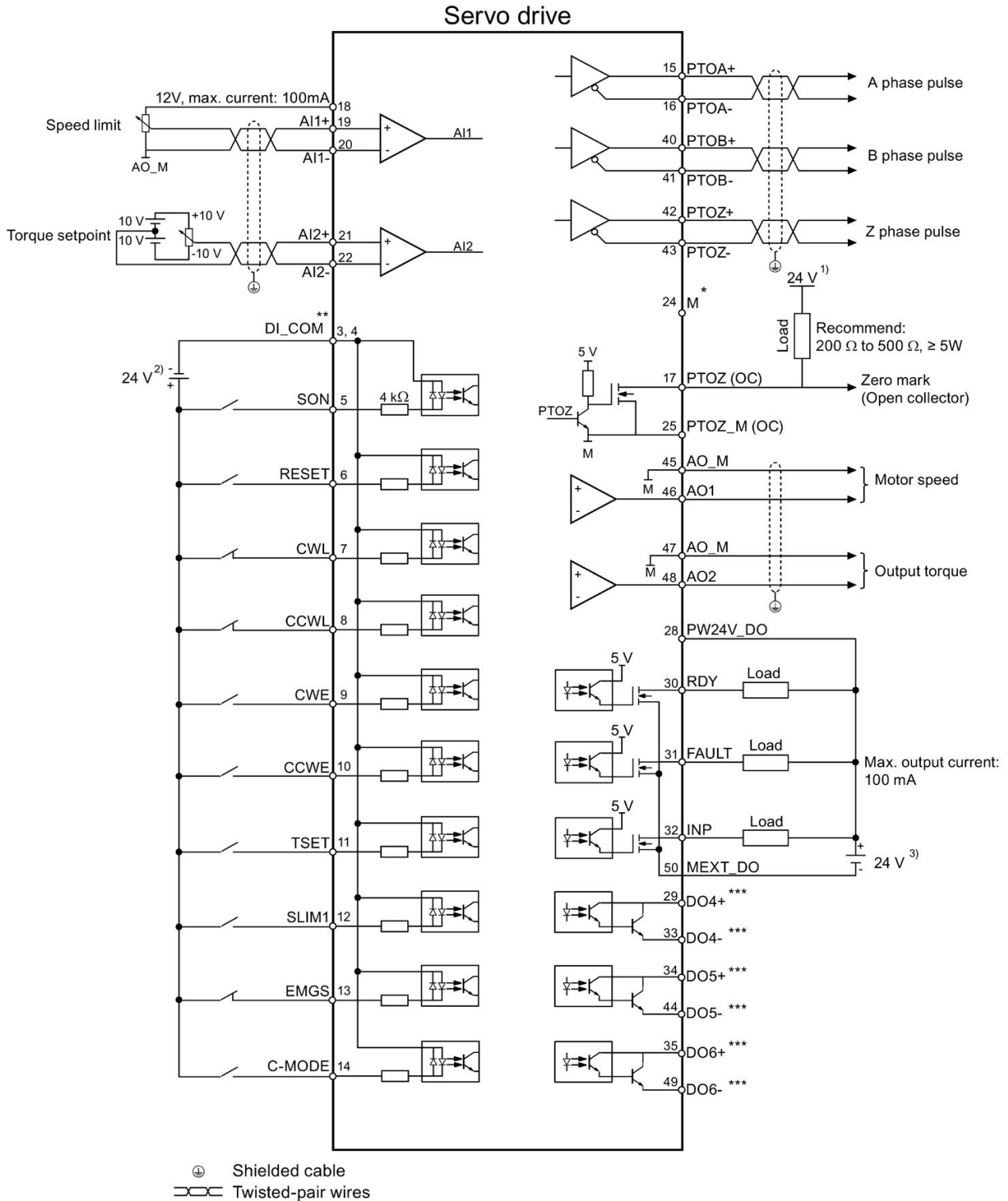

- * Digital inputs, supporting both PNP and NPN types.
- ** PTO and PTI_D reference ground, connected to the reference ground of the host controller.
- *** Digital outputs, supporting both the PNP and the NPN types.

The 24 V power supplies in the connection diagrams are as follows:

- 1) 24 V power supply for SINAMICS V90. All the PTO signals must be connected to the controller with the same 24 V power supply as SINAMICS V90.
- 2) Isolated digital input power supply. It can be the controller power supply.
- 3) Isolated digital output power supply. It can be the controller power supply.

4.4 24 V power supply/STO

The pin assignment for the 24 V power supply/STO interface is shown as follows:

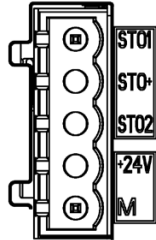
Interface	Signal name	Description
	STO 1	Safe torque off channel 1
	STO +	Specific power supply for safe torque off
	STO 2	Safe torque off channel 2
	+24 V	Power supply, 24 VDC
	M	Power supply, 0 VDC
	Maximum conductor cross-section: 1.5 mm ²	

Wiring

<p>⚠ WARNING</p> <p>Material damages and personal injuries by the drop of a hanging axis</p> <p>When the servo system is used as a hanging axis, the axis will drop if the positive and negative poles of the 24 V power supply are connected inversely. Unexpected drop of the hanging axis can cause material damages and personal injuries.</p> <ul style="list-style-type: none"> • Make sure that the 24 V power supply is correctly connected.

<p>⚠ WARNING</p> <p>Material damages and personal injuries by the drop of a hanging axis</p> <p>Unexpected drop of the hanging axis can cause material damages and personal injuries.</p> <ul style="list-style-type: none"> • It is not allowed to use the STO with a hanging axis because the axis may drop.

Note

Using the STO function

The STO1, STO+ and STO2 are short connected at the factory setting.

When the STO function is to be used, you must remove the short-circuit stick before connecting the STO interfaces. The safety function of the servo drive is SIL 2 (EN61800-5-2). If you do not need to use it any more, you must reinsert the short-circuit stick; otherwise, the motor will not run.

For detailed information about the STO function, refer to chapter "Safety Integrated basic functions" of SINAMICS V90, SIMOTICS S-1FL6 Operating Instructions.

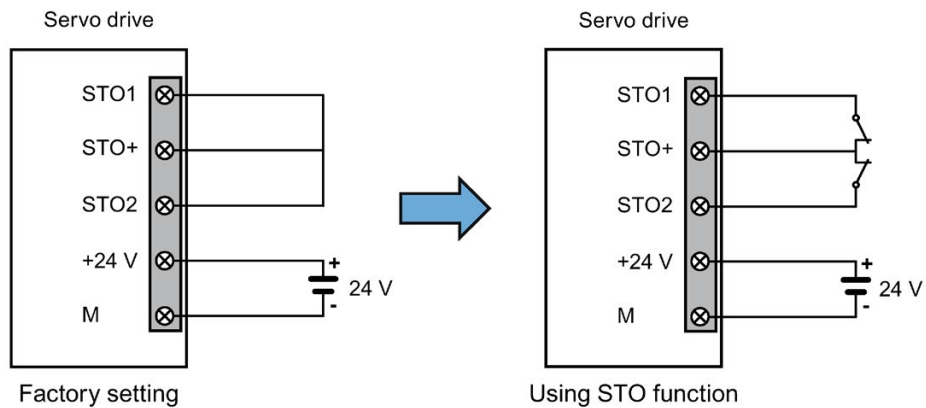

Assembling the 24 V power supply and STO cable terminals

The procedure of assembling a 24 V power cable terminal or an STO cable terminal is the same as that for a power cable terminal on the drive side of the V90 200 V servo drives.

For more information, see the SINAMICS V90, SIMOTICS S-1FL6 Operating Instructions.

Plugging the 24 V power supply and STO cables

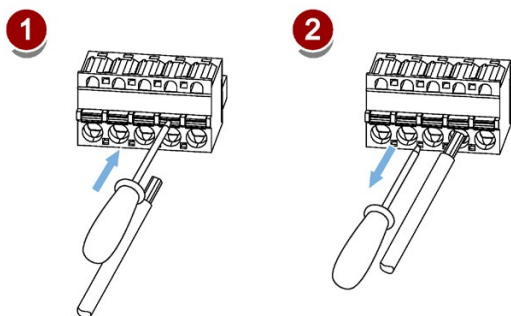

4.5 Encoder interface - X9

The SINAMICS V90 200V variant servo drive supports two kinds of encoders:

- Incremental encoder TTL 2500 ppr
- Absolute encoder single-turn 21-bit
- Absolute encoder 20-bit + 12-bit multi-turn

The SINAMICS V90 400V variant servo drive supports two kinds of encoders:

- Incremental encoder TTL 2500 ppr
- Absolute encoder 20-bit + 12-bit multi-turn

NOTICE
<p>Drive damage caused by short-circuiting between the shielding wire and the unused pin on the encoder connector</p> <p>The shielding wire may inadvertently be short-circuited to the unused pin on the to-be-assembled encoder connector. This can cause damage to the drive.</p> <ul style="list-style-type: none"> • Exercise caution when connecting the shielding cable to the encoder connector. • For more information, see Section "Assembly of cable terminals on the drive side" in the SINAMICS V90, SIMOTICS S- 1FL6 Operating Instructions.

Note

Failure to meet the EMC requirements because the cable is not shielded

If a cable is not shielded, it can not meet the EMC requirements.

- The encoder cable **must** be shielded to meet the EMC requirements.

Encoder interface - drive side

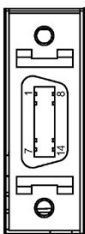
Illustration	Pin No.	Signal name	Description
	1	Biss_DataP	Absolute encoder data signal, positive
	2	Biss_DataN	Absolute encoder data signal, negative
	3	Biss_ClockN	Absolute encoder clock signal, negative
	4	Biss_ClockP	Absolute encoder clock signal, positive
	5	P5V	Encoder power supply, 5 V
	6	P5V	Encoder power supply, 5 V
	7	M	Encoder power supply, grounding
	8	M	Encoder power supply, grounding
	9	Rp	Encoder R phase positive signal
	10	Rn	Encoder R phase negative signal
	11	Bn	Encoder B phase negative signal
	12	Bp	Encoder B phase positive signal
	13	An	Encoder A phase negative signal
	14	Ap	Encoder A phase positive signal
Screw type: UNC 4-40 (plug-in terminal block) Tightening torque: 0.4 Nm			

Encoder connector - motor side

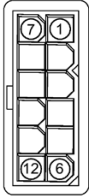
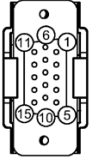
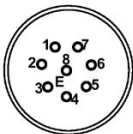

Illustration	Pin No.	Incremental encoder TTL 2500 ppr		Illustration	Absolute encoder single-turn 21-bit Absolute encoder 20-bit + 12-bit multi-turn		
		Signal	Description		Signal	Description	
Low inertia motor, shaft-height: 20 mm, 30 mm and 40 mm							
	1	P_Supply	Power supply 5 V		P_Supply	Power supply 5 V	
	2	M	Power supply 0 V		M	Power supply 0 V	
	3	A+	Phase A+		Clock_P	Clock	
	4	B+	Phase B+		Data_P	Data	
	5	R+	Phase R+		n. c.	Not connected	
	6	n. c.	Not connected		P_Supply	Power supply 5 V	
	7	P_Supply	Power supply 5 V		M	Power supply 0 V	
	8	M	Power supply 0 V		Clock_N	Inverted clock	
	9	A-	Phase A-		Data_N	Inverted data	
	10	B-	Phase B-		Shielding	Grounding	
	11	R-	Phase R-		Note The pin 11 to pin 15 of the absolute encoder connector are not connected.		
	12	Shielding	Grounding				

Illustration	Pin No.	Incremental encoder TTL 2500 ppr		Absolute encoder single-turn 21-bit Absolute encoder 20-bit + 12-bit multi-turn	
		Signal	Description	Signal	Description
Low inertia motor, shaft-height: 50 mm					
High inertia motor, shaft-height: 45 mm, 65 mm, and 90 mm					
Straight connectors:  Angular connectors: 	1	P_Supply	Power supply 5 V	P_Supply	Power supply 5 V
	2	M	Power supply 0 V	M	Power supply 0 V
	3	A+	Phase A+	n. c.	Not connected
	4	A-	Phase A-	Clock_N	Inverted clock
	5	B+	Phase B+	Data_P	Data
	6	B-	Phase B-	Clock_P	Clock
	7	R+	Phase R+	n. c.	Not connected
	8	R-	Phase R-	Data_N	Inverted data

Wiring

Low inertia motor, shaft-height: 20 mm, 30 mm and 40 mm

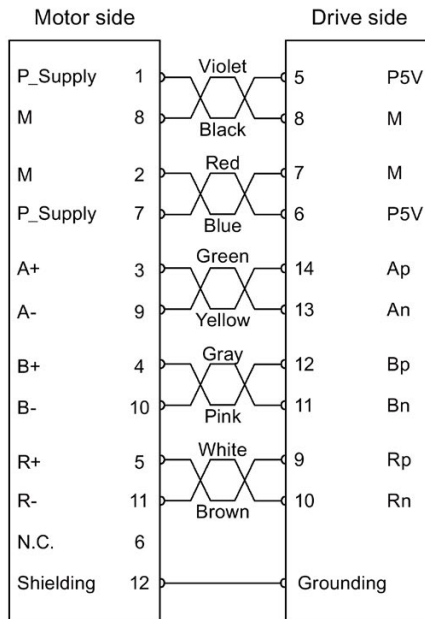

Incremental encoder TTL 2500 ppr

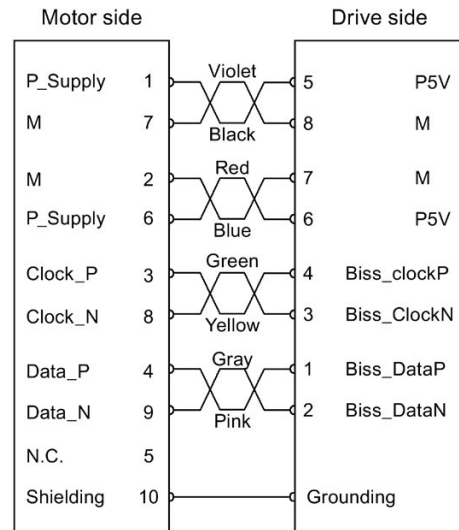

Absolute encoder single-turn 21-bit
Absolute encoder 20 bit + 12 bit multi-turn

Twisted-pair wires

Low inertia motor, shaft-height: 50 mm

High inertia motor, shaft-height: 45 mm, 65 mm, and 90 mm

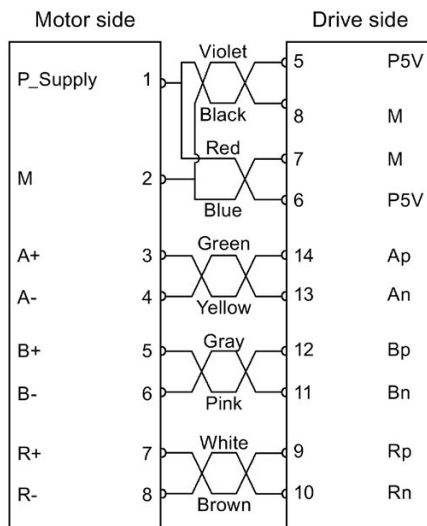

Incremental encoder TTL 2500 ppr

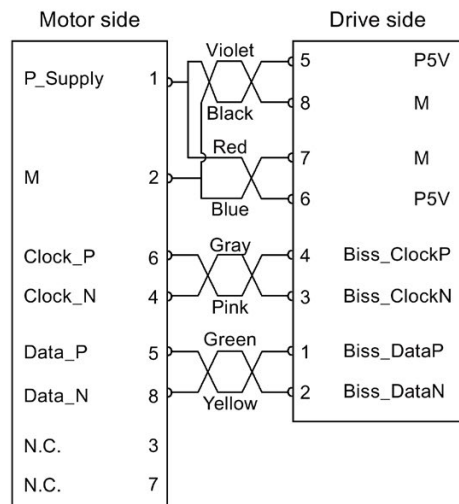

Absolute encoder single-turn 21-bit
Absolute encoder 20-bit + 12-bit multi-turn

Twisted-pair wires

Grounding

To ensure better EMC effects, you are recommended to strip the encoder cable and connect the cable shield to earth, as shown in the following figure:

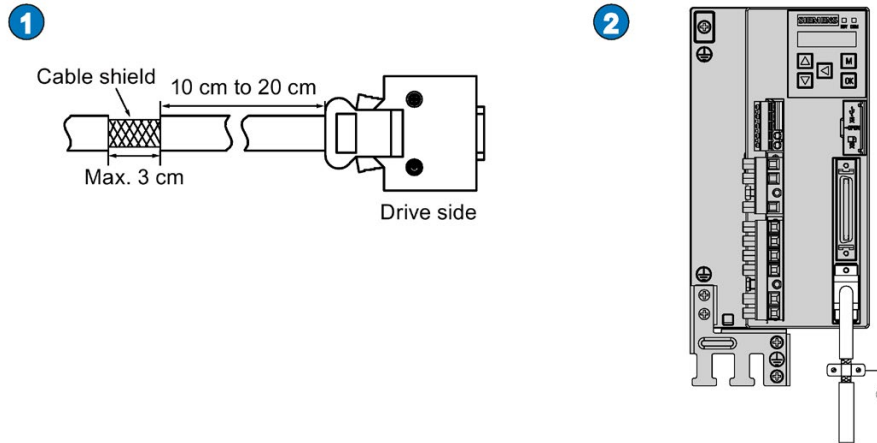

4.6 External braking resistor - DCP, R1

The SINAMICS V90 has been designed with an internal braking resistor to absorb regenerative energy from the motor. When the internal braking resistor cannot meet the braking requirements (e.g. the alarm A52901 is generated), you can connect an external braking resistor. For more information about how to select a braking resistor, see Section "Accessories" in the SINAMICS V90, SIMOTICS S-1FL6 Operating Instructions.

Note

The 200 V variant servo drive with rated power of 0.1 kW (FSA) does not have a built-in resistor.

Connecting an external braking resistor

NOTICE

Damage to the drive due to not moving the short-circuit stick between terminals DCP and R2

There is a damage to the drive if you do not move the short-circuit stick between terminals DCP and R2 when using an external resistor.

- Before connecting an external resistor to DCP and R1, remove the connection between terminals DCP and R2.

For more information about how to connect the external braking resistor, see Section "System connection (Page 52)".

4.7 Motor holding brake

You can connect the SINAMICS V90 servo drive to a servo motor with brake to use the function of motor holding brake.

NOTICE

Motor brake service life shortened due to the improper use

The motor brake is used for holding purpose only. Frequent emergency stops with the motor brake will shorten its service life.

- Unless absolutely necessary, do not apply the motor brake as an emergency stop or deceleration mechanism.

4.8 RS485 interface - X12

The SINAMICS V90 servo drives support communication with the PLCs through the RS485 interface over the USS or Modbus protocol.

Pin assignment

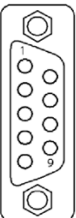
Illustration	Pin	Signal name	Description
	1	Reserved	Do not use
	2	Reserved	Do not use
	3	RS485+	RS485 differential signal
	4	Reserved	Do not use
	5	M	Ground to internal 3.3 V
	6	3.3 V	3.3 V power supply for internal signal
	7	Reserved	Do not use
	8	RS485-	RS485 differential signal
	9	Reserved	Do not use

Type: 9-pin, Sub-D, female

Prior to commissioning, read "Introduction to the BOP (Page 79)" for more information about the BOP operations. In case of any faults or alarms during commissioning, refer to Chapter "Diagnostics (Page 131)" for detailed description.

CAUTION

Danger to injury resulting from failure to observe the safety instructions

Failure to observe the instructions can result in serious injuries.

- Before your commissioning or operation, read the safety instructions in Chapter "Fundamental safety instructions (Page 5)" carefully.

WARNING

Material damages and personal injuries by the drop of a hanging axis

When the servo system is used as a hanging axis, the axis will drop if the positive and negative poles of the 24 V power supply are connected inversely. Unexpected drop of the hanging axis may cause material damages and personal injuries.

- Before commissioning, you need to make sure that a crosstie is used to hold the hanging axis in prevention of an unexpected drop. In addition, make sure that the 24 V power supply is correctly connected.

NOTICE

Firmware damage due to drive power-off during data transfer

Switching off the 24 VDC power supply for the drive during data transfer from the micro SD card/SD card to the drive can cause damage to the drive firmware.

- Do not switch off the drive power supply when the data transfer from the micro SD card/SD card to the drive is in process.

NOTICE

Existing setting data is overwritten by the setting data on the micro SD card/SD card during the drive startup

Existing setting data is overwritten by the setting data on the micro SD card/SD card during the drive startup. This situation occurs when a drive is switched on with a micro SD card/SD card containing user setting data, the existing setting data on the drive will be overwritten, or when a drive is switched on with a micro SD card/SD card containing no user setting data, the drive will automatically save the existing user setting data onto the micro SD card/SD card.

- Before starting up the drive with a micro SD card/SD card, check whether the micro SD card/SD card contains user setting data. Otherwise, the existing data on the drive may be overwritten.

Note

Plugging or unplugging the micro SD card/SD card will cause startup failure.

Do not plug or unplug the micro SD card/SD card during startup; otherwise, the drive will fail to start up.

Note

In S control mode, if the motor shaft is blocked, the blocked torque is the current effective torque. Long time shaft blocking can cause damage to the motor.

Engineering tool - SINAMICS V-ASSISTANT

You can use the engineering tool SINAMICS V-ASSISTANT to perform the trial operation.

SINAMICS V-ASSISTANT is a software tool that can be installed on a PC and runs on the Windows operating system. It communicates with the SINAMICS V90 servo drive with a USB cable (To ensure the stability of online commissioning, Siemens recommends you to use a shielded USB cable of no longer than 3 m with ferrite cores on both ends.). With SINAMICS V-ASSISTANT, you can change drive parameters and monitor drive working states in online mode.

For more information, refer to SINAMICS V-ASSISTANT Online Help. You can search and download SINAMICS V-ASSISTANT from Technical support website (<https://support.industry.siemens.com/cs/ww/en/>).

5.1 Introduction to the BOP

Overview

The SINAMICS V90 servo drive has been designed with a Basic Operator Panel (BOP) located on the front of the servo drive.

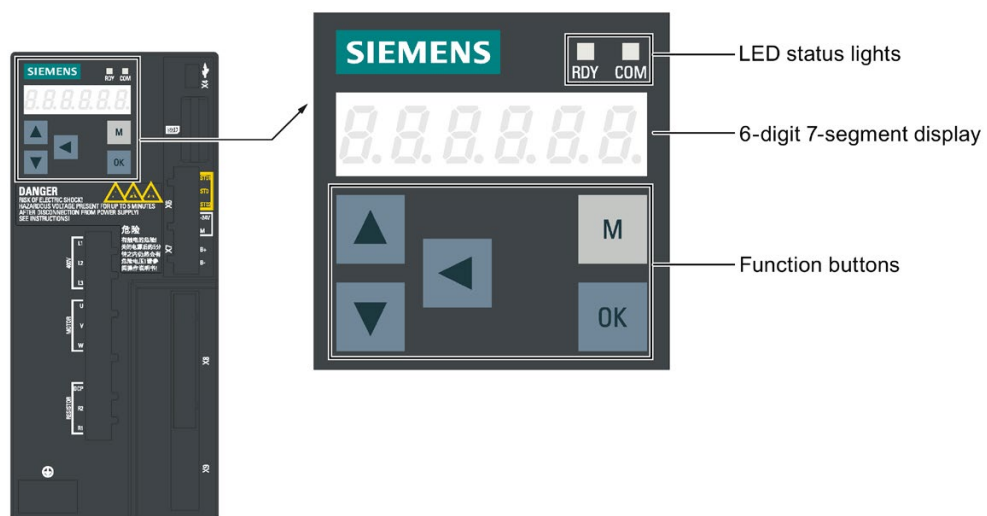

LED status indicators



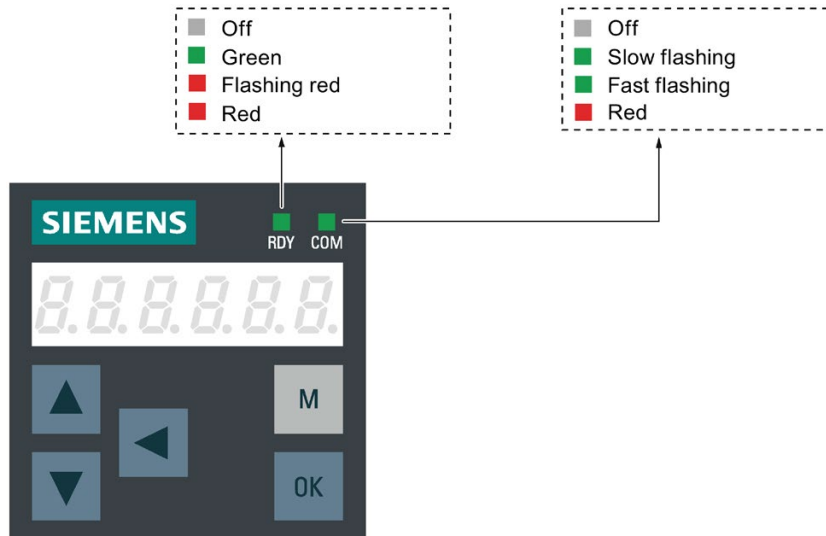





Two LED status indicators (RDY and COM) are available to indicate drive status. Both LEDs are dual color (green/red).



You can find detailed information about the status indications in the table below:

Status indicator	Color	Status	Description
RDY	-	Off	24 V control board power supply is missing
	Green	Continuously lit	The drive is in "S ON" state
	Red	Continuously lit	The drive is in "S OFF" state or in startup state
Flash at 1 Hz		Alarms or faults occurs	
COM	-	Off	Communication with PC is not active
	Green	Flash at 0.5 Hz	Communication with PC is active
		Flash at 2 Hz	Micro SD card/SD card operating (read or write)
	Red	Continuously lit	Communication with PC is in error

Control buttons

Button	Description	Functions
Basic buttons		
	M button	<ul style="list-style-type: none"> Exits from the current menu Switches between operating modes in the top level menu
	OK button	<p>Short-pressing:</p> <ul style="list-style-type: none"> Confirms selection or input Enters sub menu Acknowledges faults <p>Long-pressing:</p> <p>Activates auxiliary functions</p> <ul style="list-style-type: none"> JOG Saves parameter set in drive (RAM to ROM) Sets parameter set to default Transfers data (drive to micro SD card/SD card) Transfers data (micro SD card/SD card to drive) Updates firmware
	UP button	<ul style="list-style-type: none"> Navigates to the next item Increases a value JOG in CW (clockwise)
	DOWN button	<ul style="list-style-type: none"> Navigates to the previous item Decreases a value JOG in CCW (counter-clockwise)
	SHIFT button	Moves the cursor from digit to digit for single digit editing, including the digit of positive/negative signs
Button combinations		
	Press M + OK buttons for four seconds	Restarts the drive
	Press UP + SHIFT buttons	Moves current display to the left page when r is displayed at the upper right corner, for example 00.000r .
	Press DOWN + SHIFT buttons	Moves current display to the right page when r is displayed at the lower right corner, for example $00\text{ }10\text{r}$.





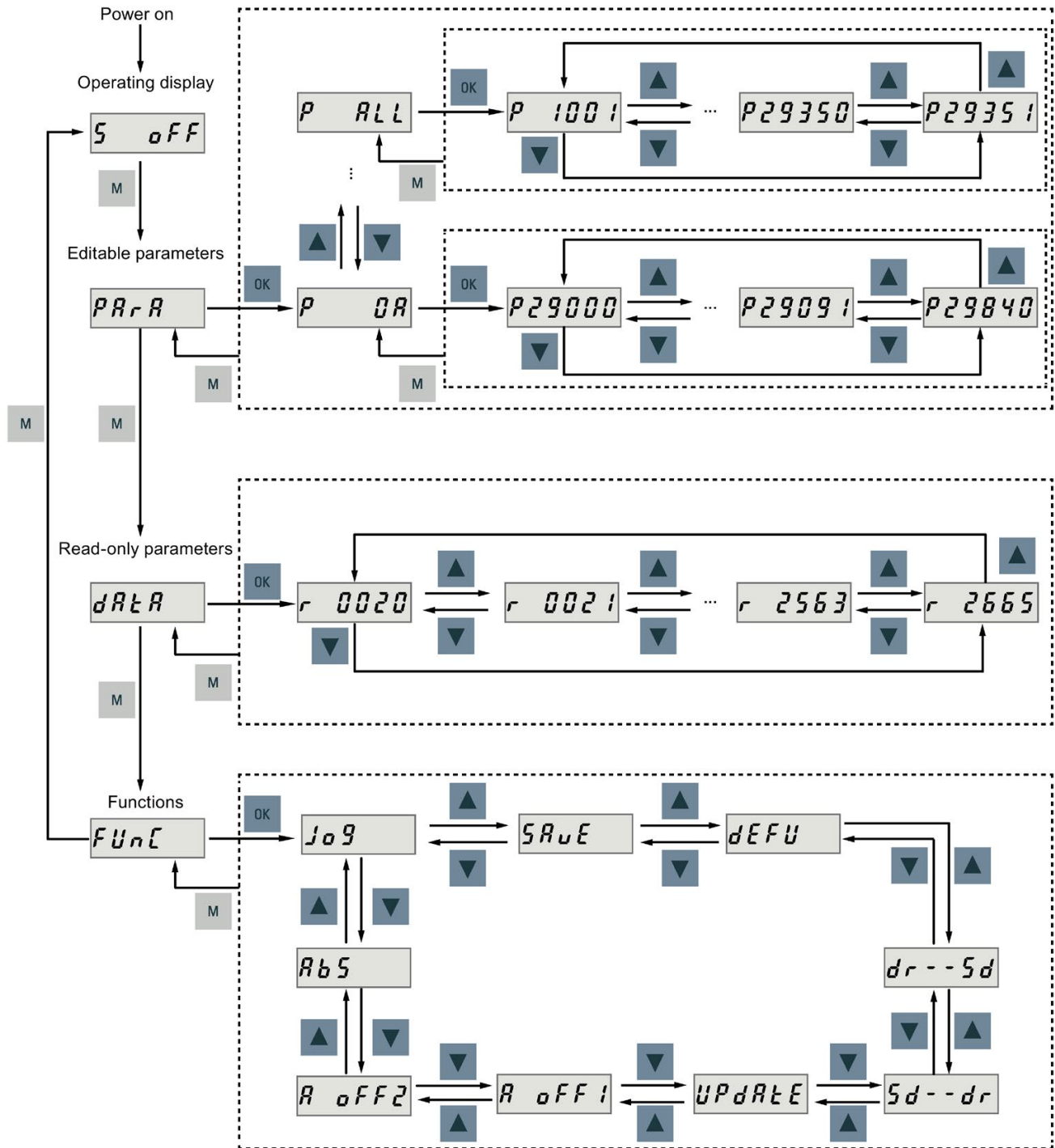









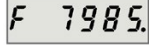

Menu structure

The overall menu structure of SINAMICS V90 BOP is designed as follows:

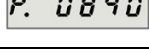

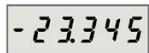
BOP displays

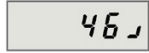
You can find the description and corresponding examples for BOP displays in the table below:

Display	Example	Description
8.8.8.8.8.8.		Drive is in startup state
-----		Drive is busy
Fxxxxx		Fault code, in the case of a single fault
F.xxxxx.		Fault code of the first fault, in the case of multiple faults
Fxxxxx.		Fault code, in the case of multiple faults
Axxxxx		Alarm code, in the case of a single alarm
A.xxxxx.		Alarm code of the first alarm, in the case of multiple alarms
Axxxxx.		Alarm code, in the case of multiple alarms
Rxxxxx		Parameter number, read-only parameter
Pxxxxx		Parameter number, editable parameter
P.xxxxx		Parameter number, editable parameter; the dot means that at least one parameter has been changed
In xx		Indexed parameter Figure after "In" indicates the number of indices. For example, "In 01" means that this indexed parameter is 1.
xxx.xxx		Negative parameter value
xxx.xx<>		Current display can be moved to left or right
xxxx.xx>		Current display can be moved to right
xxxx.xx<		Current display can be moved to left
S Off		Operating display: servo off

Display	Example	Description
Para		Editable parameter group
P 0x		Parameter group Six groups are available: 1. P0A : basic 2. P0B : gain adjustment 3. P0C : speed control 4. P0D : torque control 5. P0E : position control 6. P0F : I/O
Data		Read-only parameter group
Func		Function group
Jog		Jog function
Save		Save data in drive
defu		Restore drive to default settings
dr--sd		Save data from drive to micro SD card/SD card
sd--dr		Upload data from micro SD card/SD card to drive
Update		Update firmware
A OFF1		Adjust AI1 offset
A OFF2		Adjust AI2 offset
ABS		The zero position has not been set
A.B.S.		The zero position has been set
r xxx		Actual speed (positive direction)
r -xxx		Actual speed (negative direction)
T x.x		Actual torque (positive direction)

Display	Example	Description
T -x.x		Actual torque (negative direction)
xxxxxx		Actual position (positive direction)
xxxxxx.		Actual position (negative direction)
DCxxx.x		Actual DC link voltage
Exxxxx		Position following error
run		The motor is running
Con		The communication between the SINAMICS V-ASSISTANT and the servo drive is established. In this case, the BOP is protected from any operations except clearing alarms and acknowledging faults.

5.2 Initial commissioning in JOG mode

Prerequisites

The servo drive is connected to the servo motor without load.

Operating sequence

Note

The digital signal EMGS **must** be kept at high level (1) to ensure normal operation.

Step	Operation	Comment
1	Connect necessary units and check wirings.	It is necessary to connect the following cables: <ul style="list-style-type: none"> • Motor cable • Encoder cable • Brake cable • Line supply cable • 24 VDC cable
2	Switch on the 24 VDC power supply.	
3	Check the servo motor type. <ul style="list-style-type: none"> • If the servo motor has an incremental encoder, input motor ID (p29000). • If the servo motor has an absolute encoder, the servo drive can identify the servo motor automatically. 	Fault F52984 occurs when the servo motor is not identified. You can find the motor ID from the motor rating plate. Refer to the descriptions about the motor rating plate in "Motor components (Page 19)".

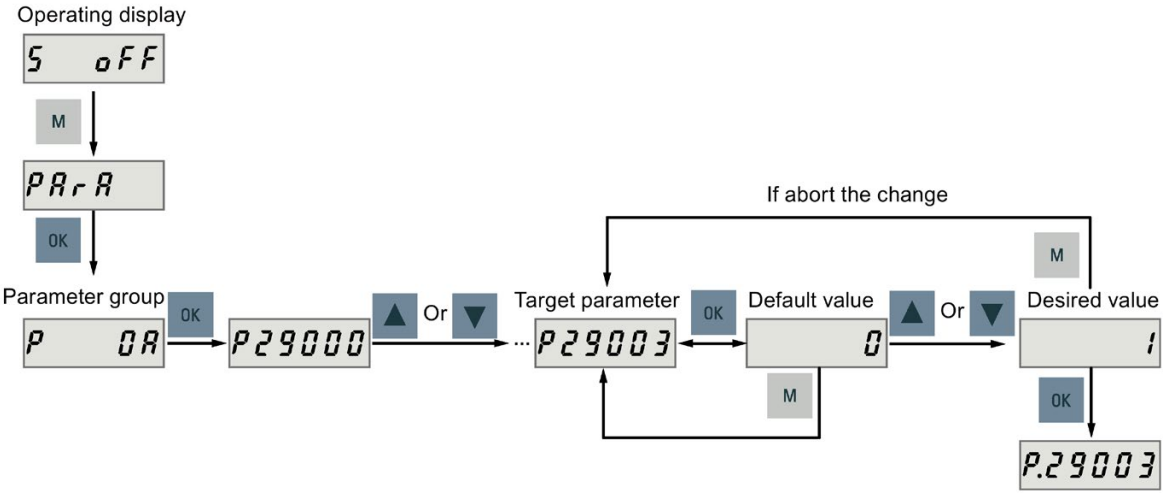
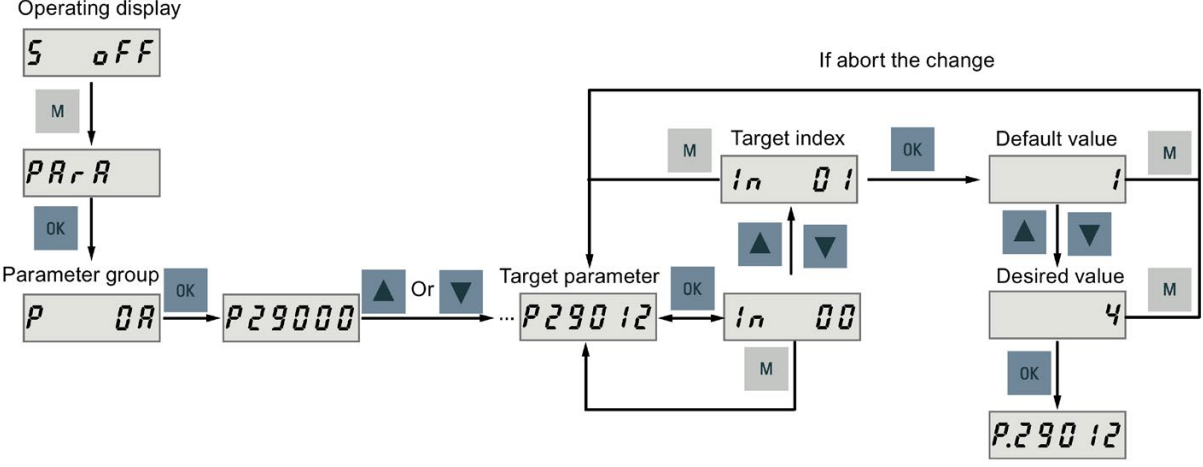
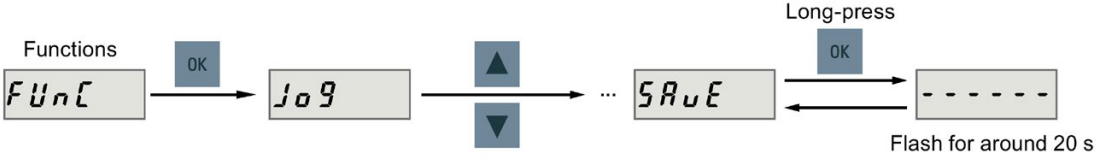
Step	Operation	Comment
4	<p>Check the direction of motor rotation. The default direction of rotation is CW (clockwise). You can change it by setting the parameter p29001 if necessary.</p> <p>Operating display</p>  <p>Parameter group P 00 → P29000 → ... → P29003 → 0 → 1 → P.29003</p> <p>If abort the change: 0 → P29003</p> <p>Setting a parameter without index (example)</p> <p>Operating display</p>  <p>Parameter group P 00 → P29000 → ... → P29012 → In 00 → 01 → 1 → 4 → P.29012</p> <p>If abort the change: 1 → In 01</p> <p>Setting a parameter with index (example)</p>	<p>p29001=0: CW p29001=1: CCW</p>
5	<p>Check the Jog speed. The default Jog speed is 100 rpm. You can change it by setting the parameter p1058.</p>	
6		 <p>Functions Func → Jog → ... → SAVE → Flash for around 20 s</p>

Step	Operation	Comment
7	Switch on the line supply.	
8	Clear faults and alarms.	Refer to Chapter "Diagnostics (Page 131)".
9	<p>For the BOP, enter the Jog menu function and press the UP or DOWN button to run the servo motor.</p> <p>Jog in speed (example)</p> <p>Jog in torque (example)</p>	
	For the engineering tool, use the Jog function to run the servo motor.	For more information about JOG with SINAMICS V-ASSISTANT, see the SINAMICS V-ASSISTANT Online Help.

5.3 Commissioning in pulse train position control mode (PTI)

Step	Operation	Comment
1	Switch off the mains supply.	
2	Power off the servo drive and connect it to host controller (for example, SIMATIC PLCs) with the signal cable.	The digital signals CWL, CCWL and EMGS must be kept at high level (1) to ensure normal operation.
3	Switch on the 24 VDC power supply.	
4	<p>Check the servo motor type.</p> <ul style="list-style-type: none"> If the servo motor has an incremental encoder, input motor ID (p29000). If the servo motor has an absolute encoder, the servo drive can identify the servo motor automatically. 	<p>Fault F52984 occurs when the servo motor is not identified.</p> <p>You can find the motor ID from the motor rating plate.</p> <p>Refer to the descriptions about the motor rating plate in "Motor components (Page 19)".</p>
5	Check current control mode by viewing value of the parameter p29003. Pulse train input position control mode (p29003=0) is the factory setting of SINAMICS V90 servo drives.	Refer to "Selecting a control mode (Page 90)".
6	Save the parameter and restart the servo drive to apply the setting of the pulse train input position control mode.	
7	Select a setpoint pulse train input form by setting parameter p29010.	<ul style="list-style-type: none"> p29010=0: pulse + direction, positive logic p29010=1: AB track, positive logic p29010=2: pulse + direction, negative logic p29010=3: AB track, negative logic <p>The factory setting is p29010=0 (pulse + direction, positive logic).</p> <p>Refer to "Selecting a setpoint pulse train input form (Page 91)".</p>
8	Select a pulse input channel by setting parameter p29014.	<ul style="list-style-type: none"> p29014=0: high-speed 5 V differential pulse train input (RS485) p29014=1: 24 V single end pulse train input <p>24V single end pulse train input is the factory setting.</p> <p>Refer to "Selecting a setpoint pulse train input channel (Page 91)".</p>

Step	Operation	Comment
9	Set the electronic gear ratio.	<p>You can use one of the following three methods to set the electronic gear ratio:</p> <ul style="list-style-type: none"> • Set the electronic gear ratio with parameters p29012 and p29013. <ul style="list-style-type: none"> – p29012: numerator of the electronic gear. Four numerators in total (p29012[0] to p29012[3]) are available. – p29013: denominator of the electronic gear. • Set the setpoint pulses per revolution. <ul style="list-style-type: none"> – p29011: number of setpoint pulses per revolution. • Calculate the electronic gear ratio by selecting mechanical structure. <ul style="list-style-type: none"> – For more information, see SINAMICS V90 V-ASSISTANT Online Help. <p>Refer to "Calculating electronic gear ratio (Page 93)".</p>
10	Check the encoder type. If it is an absolute encoder, adjust the absolute encoder with the BOP menu function "ABS".	<pre> graph TD Func[Func] -- OK --> Jo9[Jo9] Jo9 -- Up/Down --> Ellipsis[...] Ellipsis -- OK --> ABS[ABS] ABS -- Long-press OK --> Flash2s[Flash for around 2 s] Flash2s --> ABS2[A.b.S.] ABS2 -- Long-press OK --> Flash20s[Flash for around 20 s] Flash20s --> SAUE[S.A.U.E.] ABS2 -- Up/Down --> SAUE </pre>
11	Save parameters with the BOP.	
12	Switch on the line supply.	
13	Clear faults and alarms.	Refer to "Diagnostics (Page 131)".
14	Trigger SON to the high level, input the setpoint pulse train from the command device, and then the servo motor starts running.	Use a low pulse frequency at first to check the direction and speed of rotation.
15	The system commissioning in the pulse train input position control mode ends.	You can check the system performance. If it is not satisfied, you can adjust it.

5.4 Commissioning control functions

5.4.1 Selecting a control mode

Selecting a basic control mode

You can select a basic control mode by directly setting parameter p29003:

Parameter	Setting Value	Description
p29003	0 (default)	Pulse train input position control mode
	1	Internal position control mode
	2	Speed control mode
	3	Torque control mode

Control mode change for a compound control mode

For a compound control mode, you can change between two basic control modes by setting the parameter p29003 and configuring the level sensitive signal C-MODE on DI10:

p29003	C-MODE	
	0 (the first control mode)	1 (the second control mode)
4	PTI	S
5	IPos	S
6	PTI	T
7	IPos	T
8	S	T

Note

Note that if p29003 = 5 and the motor has been working in speed control mode for a certain period of time; or p29003 = 7 and the motor has been working in torque control mode for a certain period of time, the fault code F7493 might appear on the drive BOP. This, however, will not cause the motor to stop. The motor remains operative under this circumstance and you can clear the fault code manually.

Note

Fault F52904 occurs when the control mode is changed via p29003. You must save the parameter and then re-power on the servo drive to apply relevant configurations.

Note**Switching conditions**

For the switching from PTI or IPos to S or T, you are recommended to perform control mode switching after the INP (in position) signal is at high level.

For the switching from S or T to PTI or IPos, you can perform control mode switching only after the motor speed is lower than 30 rpm.

5.4.2 Selecting a setpoint pulse train input channel

As mentioned before, the SINAMICS V90 servo drive supports two channels for the setpoint pulse train input:

- 24 V single end pulse train input
- High-speed 5 V differential pulse train input

You can select one of these two channels by setting parameter p29014:

Parameter	Value	Setpoint pulse train input channel	Default
p29014	0	High-speed 5 V differential pulse train input	
	1	24V single end pulse train input	✓

The position pulse train inputs come from either of the following two terminal groups:

- X8-1 (PTIA_D+), X8-2 (PTIA_D-), X8-26 (PTIB_D+), X8-27 (PTIB_D-)
- X8-36 (PTIA_24P), X8-37 (PTIA_24M), X8-38 (PTIB_24P), X8-39 (PTIB_24M)

5.4.3 Selecting a setpoint pulse train input form

The SINAMICS V90 servo drive supports two kinds of setpoint pulse train input forms:

- AB track pulse
- Pulse + Direction

For both forms, positive logic and negative logic are supported.

Pulse train input form	Positive logic = 0		Negative logic = 1	
	Forward (CW)	Reverse (CCW)	Forward (CW)	Reverse (CCW)
AB track pulse				
Pulse + Direction				

You can select one of the setpoint pulse train input forms by setting the parameter p29010.

Parameter	Range	Default	Unit	Description
p29010	0 to 3	0	-	<ul style="list-style-type: none"> • 0: Pulse + Direction, positive logic • 1: AB track, positive logic • 2: Pulse + Direction, negative logic • 3: AB track, negative logic

Note

After modifying parameter p29010, you must perform referencing again because the reference point will be lost after p29010 changes.

5.4.4 In position (INP)

When the deviation between the position setpoint and the actual position is within the preset in-position range specified in p2544, the signal INP (in position) is output.

Parameter settings

Parameter	Value range	Setting value	Unit	Description
p2544	0 to 2147483647	40 (default)	LU	Position window (in-position range)
p29332	1 to 13	3	-	Digital output 3 assignment

DO configuration

Signal type	Signal name	Pin assignment	Setting	Description
DO	INP	X8-32 (factory setting)	1	Number of droop pulses is in the preset in-position range (parameter p2544)
			0	Droop pulses are beyond the in-position range

5.4.5 Calculating electronic gear ratio

Encoder specifications

The encoder specifications are shown as follows:

1FL6 -1A 61-0 1
 ↓

Type		Resolution
A	Incremental encoder	2500 ppr
M	Absolute encoder	21-bit single-turn
L	Absolute encoder	20-bit + 12-bit multi-turn

Electronic gear

With the function of electronic gear, you can define the motor revolutions according to the number of setpoint pulses, and sequentially define the distance of mechanical movement. The minimum travelling distance of load shaft according to one setpoint pulse is called a length unit (LU); for example, one pulse results in 1 µm movement.

Benefits of electronic gear (example):

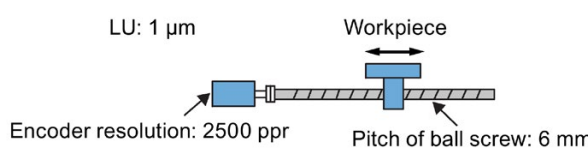
Move the workpiece for 10 mm: 	
Without electronic gear	With electronic gear
Required number of setpoint pulses: $2500 \text{ ppr} \times 4 \times (10 \text{ mm}/6 \text{ mm}) = 16666$	Required number of setpoint pulses: $(10 \text{ mm} \times 1000) / 1 \text{ LU} = 10000$

The electronic gear ratio is a multiplier factor to pulse train setpoint. It is realized with a numerator and a denominator. Four numerators (p29012[0], p29012[1], p29012[2], p29012[3]) and one denominator (p29013) are used for the four electronic gear ratios:

Parameter	Range	Factory setting	Unit	Description
p29012[0]	1 to 10000	1	-	The first numerator of electronic gear
p29012[1]	1 to 10000	1	-	The second numerator of electronic gear
p29012[2]	1 to 10000	1	-	The third numerator of electronic gear
p29012[3]	1 to 10000	1	-	The forth numerator of electronic gear
p29013	1 to 10000	1	-	The denominator of electronic gear

These four electronic gear ratios can be selected with the combination of the digital input signals EGEAR1 and EGEAR2:

EGEAR2 : EGEAR1	Electronic gear ratio	Ratio value
0 : 0	Electronic gear ratio 1	p29012[0] : p29013
0 : 1	Electronic gear ratio 2	p29012[1] : p29013
1 : 0	Electronic gear ratio 3	p29012[2] : p29013
1 : 1	Electronic gear ratio 4	p29012[3] : p29013

Note

After a gear ratio is switched to another one via digital inputs, you need to wait five seconds and then perform **SERVO ON**.

Note

The range of electronic gear ratio is from 0.02 to 500.

The electronic gear ratio can be set at **SERVO OFF** state only. After the setting, you need to reference the drive again.

Examples for calculating the electronic gear ratio

Step	Description	Mechanism	
		Ball screw	Disc table
1	Identify mechanism	<ul style="list-style-type: none"> Pitch of ball screw: 6 mm Deduction gear ratio: 1:1 	<ul style="list-style-type: none"> Rotary angle: 360° Deduction gear ratio: 1:3
2	Identify encoder resolution	10000	10000
3	Define LU	1 LU=1 µm	1 LU=0.01°
4	Calculate the travel distance per load shaft revolution	6/0.001=6000 LU	360°/0.01°=36000 LU
5	Calculate electronic gear ratio	$(1/6000) / (1/1) \times 10000 = 10000/6000$	$(1/36000) / (1/3) \times 10000 = 10000/12000$
6	Set parameters	p29012/ p29013 $10000/6000 = 5/3$	$10000/12000 = 5/6$

5.4.6 Absolute position system

When the SINAMICS V90 servo drive uses a servo motor with an absolute encoder, the current absolute position can be detected and transmitted to the controller. With this function of absolute position system, you can perform motion control task immediately after the servo system is powered on, which means you do not have to carry out referencing or zero position operation beforehand.

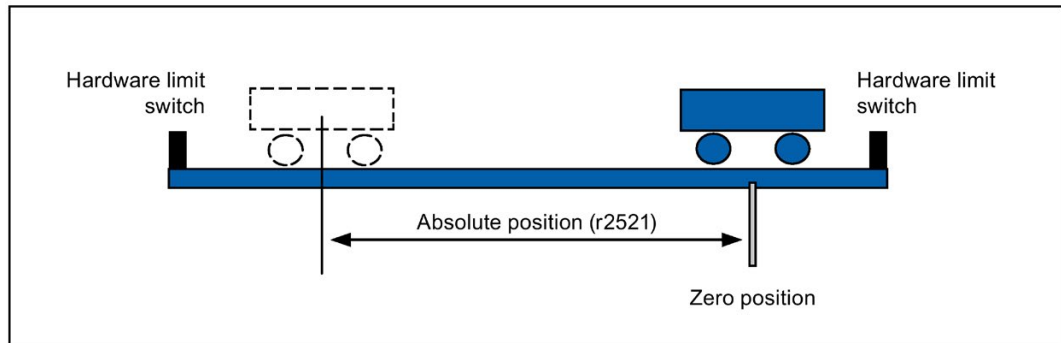

Restrictions

The absolute position system **cannot** be configured under the following conditions:

- Internal position control (IPos)
- Speed control (S)
- Torque control (T)
- Control change mode
- Strokeless coordinate system, for example, rotary shaft, infinitely long positioning operation
- Change of electronic gear after referencing
- Use of alarm code output

Parameters

6.1 Overview

The section below lists all the parameters of the SINAMICS V90 servo drive.

Parameter number

Numbers prefixed with an "r" indicate that parameter is a read-only parameter.

Numbers prefixed with a "p" indicate that the parameter is an editable parameter.

Effective

This indicates the conditions for making parameterization effective. Two conditions are possible:

- IM (**I**mmediately): Parameter value becomes effective immediately after changing.
- RE (**R**eset): Parameter value becomes effective after repower-on.

Can be changed

This indicates when the parameter can be changed. Two states are possible:

- U (Run): Can be changed in the "**R**unning" state when the drive is in "S ON" state. The "RDY" LED lights up green.
- T (Ready to run): Can be changed in the "**R**eady" state when the drive is in "S OFF" state. The "RDY" LED lights up red.

Note

When judging the state of the drive according to the "RDY" LED, ensure that no faults or alarms exist.

Data type

Date type	Abbreviation	Description
Integer16	I16	16-bit integer
Integer32	I32	32-bit integer
Unsigned8	U8	8-bit unsigned integer
Unsigned16	U16	16-bit unsigned integer
Unsigned32	U32	32-bit unsigned integer
FloatingPoint32	Float	32-bit floating point number

Parameter groups

The SINAMICS V90 parameters are divided into the following groups:

Parameter group	Available parameters	Parameter group display on the BOP
Basic parameters	p290xx	
Gain adjustment parameters	p291xx	
Speed control parameters	p10xx to p14xx, p21xx	
Torque control parameters	p15xx to p16xx	
Position control parameters	p25xx to p26xx, p292xx	
I/O parameters	p293xx	
Status monitoring parameters	All read-only parameters	

6.2 Parameter list

Editable parameters

The values of the parameters marked with an asterisk (*) may be changed after commissioning. Make sure you back up the parameters first as required if you desire to replace the motor. The default values of the parameters marked with two asterisks (**) are motor dependent. They may have different default values when different motors are connected.

Par. No.	Name	Min	Max	Factory Setting	Unit	Data type	Effective	Can be changed
p0748	CU invert digital outputs	0	63	0	-	U32	IM	T, U
	Description: Inverts the signals at the digital outputs. Bit 0 to bit 5: invert signal for DO 1 to DO 6. Bit = 0: not inverted Bit = 1: inverted							
p0795	Digital inputs simulation mode	1	4294967295	0	-	U32	IM	T, U
	Description: Sets the simulation mode for digital inputs. Bit 0 to bit 9: set the simulation mode for DI 1 to DI 10 Bit = 0: terminal eval Bit = 1: simulation							
	Note: If a digital input is used as signal source for the function "STO" then it is not permissible to select the simulation mode and this is rejected. This parameter is not saved when data is backed up.							

6.2 Parameter list

Par. No.	Name	Min	Max	Factory Setting	Unit	Data type	Effective	Can be changed
p0796	Digital inputs simulation mode setpoint	1	4294967295	0	-	U32	IM	T, U
	Description: Sets the setpoint for the input signals in the digital input simulation mode. Bit 0 to bit 9: set the setpoint for DI 1 to DI 10 Bit = 0: low Bit = 1: high							
	Note: This parameter is not saved when data is backed up.							
p0927	Parameter authority	0000 bin	0011 bin	0011 bin	-	U16	IM	T
	Description: Sets the interface via which parameters can be changed. Bit definition: Bit 0: V-ASSISTANT Bit 1: BOP Value definition for a bit: 0: read only 1: read and write							
	Note: If p927.0 = 0, the V-ASSISTANT can only be used to read parameters, all other functions won't work.							
p1001	Fixed speed setpoint 1	-210000.000	210000.000	0.000	rpm	Float	IM	T, U
	Description: Sets a value for the fixed speed / velocity setpoint 1.							
p1002	Fixed speed setpoint 2	-210000.000	210000.000	0.000	rpm	Float	IM	T, U
	Description: Sets a value for the fixed speed / velocity setpoint 2.							
p1003	Fixed speed setpoint 3	-210000.000	210000.000	00.000	rpm	Float	IM	T, U
	Description: Sets a value for the fixed speed / velocity setpoint 3.							
p1004	Fixed speed setpoint 4	-210000.000	210000.000	0.000	rpm	Float	IM	T, U
	Description: Sets a value for the fixed speed / velocity setpoint 4.							
p1005	Fixed speed setpoint 5	-210000.000	210000.000	0.000	rpm	Float	IM	T, U
	Description: Sets a value for the fixed speed / velocity setpoint 5.							
p1006	Fixed speed setpoint 6	-210000.000	210000.000	0.000	rpm	Float	IM	T, U
	Description: Sets a value for the fixed speed / velocity setpoint 6.							
p1007	Fixed speed setpoint 7	-210000.000	210000.000	0.000	rpm	Float	IM	T, U
	Description: Sets a value for the fixed speed / velocity setpoint 7.							
p1058	Jog 1 speed setpoint	0.00	210000.000	100.00	rpm	Float	IM	T
	Description: Sets the speed/velocity for Jog 1. Jogging is level-triggered and allows the motor to be incrementally moved.							
	Note: The parameter values displayed on the BOP are integers.							
p1082 *	Maximum speed	0.000	210000.000	1500.000	rpm	Float	IM	T
	Description: Sets the highest possible speed.							
	Notice: After the value has been modified, no further parameter modifications can be made.							
	Note: The parameter values displayed on the BOP are integers. The parameter applies for both motor directions. The parameter has a limiting effect and is the reference quantity for all ramp-up and ramp-down times (e.g. down ramps, ramp-function generator and motor potentiometer). The range of the parameter is different when connect with different motors.							

Par. No.	Name	Min	Max	Factory Setting	Unit	Data type	Effective	Can be changed
p1083 *	Speed limit in positive direction of rotation	0.000	210000.000	210000.000	rpm	Float	IM	T, U
	Description: Sets the maximum speed for the positive direction.							
	Note: The parameter values displayed on the BOP are integers.							
p1086 *	Speed limit in negative direction of rotation	-210000.000	0.000	-210000.000	rpm	Float	IM	T, U
	Description: Sets the speed limit for the negative direction.							
	Note: The parameter values displayed on the BOP are integers.							
p1115	Ramp-function generator selection	0	1	0	-	I16	IM	T
	Description: Sets the ramp-function generator type.							
	Note: Another ramp-function generator type can only be selected when the motor is at a standstill.							
p1120	Ramp-function generator ramp-up time	0.000	999999.000	1	s	Float	IM	T, U
	Description: The ramp-function generator ramps-up the speed setpoint from standstill (setpoint = 0) up to the maximum speed (p1082) in this time.							
	Dependency: Refer to p1082							
p1121	Ramp-function generator ramp-down time	0.000	999999.000	1	s	Float	IM	T, U
	Description: Sets the ramp-down time for the ramp-function generator.							
	The ramp-function generator ramps-down the speed setpoint from the maximum speed (p1082) down to standstill (setpoint = 0) in this time.							
	Further, the ramp-down time is always effective for OFF1.							
Dependency: Refer to p1082								
p1130	Ramp-function generator initial rounding-off time	0.000	30.000	0.000	s	Float	IM	T, U
	Description: Sets the initial rounding-off time for the extended ramp generator. The value applies to ramp-up and ramp-down.							
	Note: Rounding-off times avoid an abrupt response and prevent damage to the mechanical system.							
p1131	Ramp-function generator final rounding-off time	0.000	30.000	0.000	s	Float	IM	T, U
	Description: Sets the final rounding-off time for the extended ramp generator. The value applies to ramp-up and ramp-down.							
	Note: Rounding-off times avoid an abrupt response and prevent damage to the mechanical system.							
p1215 *	Motor holding brake configuration	0	3	0	-	I16	IM	T
	Description: Sets the holding brake configuration.							
	Dependency: Refer to p1216, p1217, p1226, p1227, p1228							
	Caution: For the setting p1215 = 0, if a brake is used, it remains closed. If the motor moves, this will destroy the brake.							
	Notice: If p1215 was set to 1 or if p1215 was set to 3, then when the pulses are suppressed, the brake is closed even if the motor is still rotating.							
	Note: If a holding brake integrated in the motor is used, then it is not permissible that p1215 is set to 3. The parameter can only be set to zero when the pulses are inhibited.							

6.2 Parameter list

Par. No.	Name	Min	Max	Factory Setting	Unit	Data type	Effective	Can be changed
p1216 *	Motor holding brake opening time	0	10000	100	ms	Float	IM	T, U
	<p>Description: Sets the time to open the motor holding brake. After controlling the holding brake (opens), the speed/velocity setpoint remains at zero for this time. After this, the speed/velocity setpoint is enabled.</p>							
	<p>Dependency: Refer to p1215, p1217</p>							
	<p>Note: For a motor with integrated brake, this time is pre-assigned the value saved in the motor. For p1216 = 0 ms, the monitoring and the message A7931 "Brake does not open" are deactivated.</p>							
p1217 *	Motor holding brake closing time	0	10000	100	ms	Float	IM	T, U
	<p>Description: Sets the time to apply the motor holding brake. After OFF1 or OFF3 and the holding brake is controlled (the brake closes), then the drive remains closed-loop controlled for this time stationary with a speed setpoint/velocity setpoint of zero. The pulses are suppressed when the time expires.</p>							
	<p>Dependency: Refer to p1215, p1216</p>							
	<p>Note: For a motor with integrated brake, this time is pre-assigned the value saved in the motor. For p1217 = 0 ms, the monitoring and the message A07932 "Brake does not close" are deactivated.</p>							
p1226	Threshold for zero speed detection	0.00	210000.00	20.00	rpm	Float	IM	T, U
	<p>Description: Sets the speed threshold for the standstill identification. Acts on the actual value and setpoint monitoring. When braking with OFF1 or OFF3, when the threshold is undershot, standstill is identified. The following applies when the brake control is activated: When the threshold is undershot, the brake control is started and the system waits for the brake closing time in p1217. The pulses are then suppressed. If the brake control is not activated, the following applies: When the threshold is undershot, the pulses are suppressed and the drive coasts down.</p>							
	<p>Dependency: Refer to p1215, p1216, p1217, p1227</p>							
	<p>Notice: For reasons relating to the compatibility to earlier firmware versions, a parameter value of zero in indices 1 to 31 is overwritten with the parameter value in index 0 when the drive boots.</p>							
	<p>Note: Standstill is identified in the following cases: - The speed actual value falls below the speed threshold in p1226 and the time started after this in p1228 has expired. - The speed setpoint falls below the speed threshold in p1226 and the time started after this in p1227 has expired. The actual value sensing is subject to measuring noise. For this reason, standstill cannot be detected if the speed threshold is too low.</p>							
	<p>Notice: For reasons relating to the compatibility to earlier firmware versions, a parameter value of zero in indices 1 to 31 is overwritten with the parameter value in index 0 when the drive boots.</p>							
p1227	Zero speed detection monitoring time	0.000	300.000	300.000	s	Float	IM	T, U
	<p>Description: Sets the monitoring time for the standstill identification. When braking with OFF1 or OFF3, standstill is identified after this time has expired, after the setpoint speed has fallen below p1226. After this, the brake control is started, the system waits for the closing time in p1217 and then the pulses are suppressed.</p>							
	<p>Dependency: Refer to p1215, p1216, p1217, p1226</p>							
	<p>Notice: The setpoint is not equal to zero dependent on the selected value. This can therefore cause the monitoring time in p1227 to be exceeded. In this case, for a driven motor, the pulses are not suppressed..</p>							

Par. No.	Name	Min	Max	Factory Setting	Unit	Data type	Effective	Can be changed
	<p>Note: Standstill is identified in the following cases:</p> <ul style="list-style-type: none"> - The speed actual value falls below the speed threshold in p1226 and the time started after this in p1228 has expired. - The speed setpoint falls below the speed threshold in p1226 and the time started after this in p1227 has expired. <p>For p1227 = 300.000 s, the following applies: Monitoring is de-activated.</p> <p>For p1227 = 0.000 s, the following applies: With OFF1 or OFF3 and a ramp-down time = 0, the pulses are immediately suppressed and the motor "coasts" down.</p>							
p1228	Pulse suppression delay time	0.000	299.000	0.000	s	Float	IM	T, U
	<p>Description: Sets the delay time for pulse suppression. After OFF1 or OFF3, the pulses are canceled, if at least one of the following conditions is fulfilled:</p> <ul style="list-style-type: none"> - The speed actual value falls below the threshold in p1226 and the time started after this in p1228 has expired. - The speed setpoint falls below the threshold in p1226 and the time started after this in p1227 has expired. <p>Dependency: Refer to p1226, p1227</p> <p>Notice: When the motor holding brake is activated, pulse cancellation is additionally delayed by the brake closing time (p1217).</p>							
p1414	Speed setpoint filter activation	0000 bin	0011 bin	0000 bin	-	U16	IM	T, U
	<p>Description: Setting for activating/de-activating the speed setpoint filter.</p> <p>Dependency: The individual speed setpoint filters are parameterized as of p1415.</p> <p>Note: The drive unit displays the value in hex format. To know the logic (high/low) assignment to each bit, you must convert the hex number to the binary number, for example, FF (hex) = 11111111 (bin).</p>							
p1415	Speed setpoint filter 1 type	0	2	0	-	I16	IM	T, U
	<p>Description: Sets the type for speed setpoint filter 1.</p> <p>Dependency: PT1 low pass: p1416 PT2 low pass: p1417, p1418 General filter: p1417 ... p1420</p>							
p1416	Speed setpoint filter 1 time constant	0.00	5000.00	0.00	ms	Float	IM	T, U
	<p>Description: Sets the time constant for the speed setpoint filter 1 (PT1).</p> <p>Dependency: Refer to p1414, p1415</p> <p>Note: This parameter is only effective if the filter is set as a PT1 low pass.</p>							
p1417	Speed setpoint filter 1 denominator natural frequency	0.5	16000.0	1999.0	Hz	Float	IM	T, U
	<p>Description: Sets the denominator natural frequency for speed setpoint filter 1 (PT2, general filter).</p> <p>Dependency: Refer to p1414, p1415</p> <p>Note: This parameter is only effective if the speed filter is parameterized as a PT2 low pass or as general filter. The filter is only effective if the natural frequency is less than half of the sampling frequency.</p>							
p1418	Speed setpoint filter 1 denominator damping	0.001	10.000	0.700	-	Float	IM	T, U
	<p>Description: Sets the denominator damping for speed setpoint filter 1 (PT2, general filter).</p> <p>Dependency: Refer to p1414, p1415</p> <p>Note: This parameter is only effective if the speed filter is parameterized as a PT2 low pass or as general filter.</p>							

6.2 Parameter list

Par. No.	Name	Min	Max	Factory Setting	Unit	Data type	Effective	Can be changed
p1419	Speed setpoint filter 1 numerator natural frequency	0.5	16000.0	1999.0	Hz	Float	IM	T, U
	Description: Sets the numerator natural frequency for speed setpoint filter 1 (general filter).							
	Dependency: Refer to p1414, p1415							
	Note: This parameter is only effective if the speed filter is set as a general filter. The filter is only effective if the natural frequency is less than half of the sampling frequency.							
p1420	Speed setpoint filter 1 numerator damping	0.001	10.000	0.700	-	Float	IM	T, U
	Description: Sets the numerator damping for speed setpoint filter 1 (general filter).							
	Dependency: Refer to p1414, p1415							
	Note: This parameter is only effective if the speed filter is set as a general filter.							
p1421	Speed setpoint filter 2 type	0	2	0	-	I16	IM	T, U
	Description: Sets the type for speed setpoint filter 2.							
	Dependency: PT1 low pass: p1422 PT2 low pass: p1423, p1424 General filter: p1423 ... p1426							
p1422	Speed setpoint filter 2 time constant	0.00	5000.00	0.00	ms	Float	IM	T, U
	Description: Sets the time constant for the speed setpoint filter 2 (PT1).							
	Dependency: Refer to p1414, p1421							
	Note: This parameter is only effective if the speed filter is set as a PT1 low pass.							
p1423	Speed setpoint filter 2 denominator natural frequency	0.5	16000.0	1999.0	Hz	Float	IM	T, U
	Description: Sets the denominator natural frequency for speed setpoint filter 2 (PT2, general filter).							
	Dependency: Refer to p1414, p1421							
	Note: This parameter is only effective if the speed filter is parameterized as a PT2 low pass or as general filter. The filter is only effective if the natural frequency is less than half of the sampling frequency.							
p1424	Speed setpoint filter 2 denominator damping	0.001	10.000	0.700	-	Float	IM	T, U
	Description: Sets the denominator damping for speed setpoint filter 2 (PT2, general filter).							
	Dependency: Refer to p1414, p1421							
	Note: This parameter is only effective if the speed filter is parameterized as a PT2 low pass or as general filter.							
p1425	Speed setpoint filter 2 numerator natural frequency	0.5	16000.0	1999.0	Hz	Float	IM	T, U
	Description: Sets the numerator natural frequency for speed setpoint filter 2 (general filter).							
	Dependency: Refer to p1414, p1421							
	Note: This parameter is only effective if the speed filter is set as a general filter. The filter is only effective if the natural frequency is less than half of the sampling frequency.							
p1426	Speed setpoint filter 2 numerator damping	0.000	10.000	0.700	-	Float	IM	T, U
	Description: Sets the numerator damping for speed setpoint filter 2 (general filter).							
	Dependency: Refer to p1414, p1421							
	Note: This parameter is only effective if the speed filter is set as a general filter.							

Par. No.	Name	Min	Max	Factory Setting	Unit	Data type	Effective	Can be changed
p1441	Actual speed smoothing time	0.00	50.00	0.00	ms	Float	IM	T, U
	Description: Sets the smoothing time constant (PT1) for the speed actual value.							
	Note: The speed actual value should be smoothed for increment encoders with a low pulse number. After this parameter has been changed, we recommend that the speed controller is adapted and/or the speed controller settings checked Kp (p29120) and Tn (p29121).							
p1520 *	Torque limit upper	-1000000.00	2000000.00	0.00	Nm	Float	IM	T, U
	Description: Sets the fixed upper torque limit.							
	Danger: Negative values when setting the upper torque limit (p1520 < 0) can result in the motor accelerating in an uncontrollable fashion. Notice: The maximum value depends on the maximum torque of the connected motor.							
p1521 *	Torque limit lower	-2000000.00	1000000.00	0.00	Nm	Float	IM	T, U
	Description: Sets the fixed lower torque limit.							
	Danger: Positive values when setting the lower torque limit (p1521 > 0) can result in the motor accelerating in an uncontrollable fashion. Notice: The maximum value depends on the maximum torque of the connected motor.							
p1656 *	Activates current setpoint filter	0000 bin	1111 bin	0001 bin	-	U16	IM	T, U
	Description: Setting for activating/de-activating the current setpoint filter.							
	Dependency: The individual current setpoint filters are parameterized as of p1658. Note: If not all of the filters are required, then the filters should be used consecutively starting from filter 1. The drive unit displays the value in hex format. To know the logic (high/low) assignment to each bit, you must convert the hex number to the binary number, for example, FF (hex) = 11111111 (bin).							
p1658 *	Current setpoint filter 1 denominator natural frequency	0.5	16000.0	1999.0	Hz	Float	IM	T, U
	Description: Sets the denominator natural frequency for current setpoint filter 1 (PT2, general filter).							
	Dependency: The current setpoint filter 1 is activated via p1656.0 and parameterized via p1658 ... p1659.							
p1659 *	Current setpoint filter 1 denominator damping	0.001	10.000	0.700	-	Float	IM	T, U
	Description: Sets the denominator damping for current setpoint filter 1.							
	Dependency: The current setpoint filter 1 is activated via p1656.0 and parameterized via p1658 ... p1659.							
p1663	Current setpoint filter 2 denominator natural frequency	0.5	16000.0	1000.0	Hz	Float	IM	T, U
	Description: Sets the denominator natural frequency for current setpoint filter 2 (PT2, general filter).							
	Dependency: Current setpoint filter 2 is activated via p1656.1 and parameterized via p1663 ... p1666.							
p1664	Current setpoint filter 2 denominator damping	0.001	10.000	0.300	-	Float	IM	T, U
	Description: Sets the denominator damping for current setpoint filter 2.							
	Dependency: Current setpoint filter 2 is activated via p1656.1 and parameterized via p1663 ... p1666.							
p1665	Current setpoint filter 2 numerator natural frequency	0.5	16000.0	1000.0	Hz	Float	IM	T, U
	Description: Sets the numerator natural frequency for current setpoint filter 2 (general filter).							
	Dependency: Current setpoint filter 2 is activated via p1656.1 and parameterized via p1662 ... p1666.							
p1666	Current setpoint filter 2 numerator damping	0.000	10.000	0.010	-	Float	IM	T, U
	Description: Sets the numerator damping for current setpoint filter 2.							
	Dependency: Current setpoint filter 2 is activated via p1656.1 and parameterized via p1663 ... p1666.							

6.2 Parameter list

Par. No.	Name	Min	Max	Factory Setting	Unit	Data type	Effective	Can be changed
p1668	Current setpoint filter 3 denominator natural frequency	0.5	16000.0	1000.0	Hz	Float	IM	T, U
	Description: Sets the denominator natural frequency for current setpoint filter 3 (PT2, general filter).							
	Dependency: Current setpoint filter 3 is activated via p1656.2 and parameterized via p1668 ... p1671.							
p1669	Current setpoint filter 3 denominator damping	0.001	10.000	0.300	-	Float	IM	T, U
	Description: Sets the denominator damping for current setpoint filter 3.							
	Dependency: Current setpoint filter 3 is activated via p1656.2 and parameterized via p1668 ... p1671.							
p1670	Current setpoint filter 3 numerator natural frequency	0.5	16000.0	1000.0	Hz	Float	IM	T, U
	Description: Sets the numerator natural frequency for current setpoint filter 3 (general filter).							
	Dependency: Current setpoint filter 3 is activated via p1656.2 and parameterized via p1668 ... p1671.							
p1671	Current setpoint filter 3 numerator damping	0.000	10.000	0.010	-	Float	IM	T, U
	Description: Sets the numerator damping for current setpoint filter 3.							
	Dependency: Current setpoint filter 3 is activated via p1656.2 and parameterized via p1668 ... p1671.							
p1673	Current setpoint filter 4 denominator natural frequency	0.5	16000.0	1000.0	Hz	Float	IM	T, U
	Description: Sets the denominator natural frequency for current setpoint filter 4 (PT2, general filter).							
	Dependency: Current setpoint filter 4 is activated via p1656.3 and parameterized via p1673 ... p1675.							
p1674	Current setpoint filter 4 denominator damping	0.001	10.000	0.300	-	Float	IM	T, U
	Description: Sets the denominator damping for current setpoint filter 4.							
	Dependency: Current setpoint filter 4 is activated via p1656.3 and parameterized via p1673 ... p1675.							
p1675	Current setpoint filter 4 numerator natural frequency	0.5	16000.0	1000.0	Hz	Float	IM	T, U
	Description: Sets the numerator natural frequency for current setpoint filter 4 (general filter).							
	Dependency: Current setpoint filter 4 is activated via p1656.3 and parameterized via p1673 ... p1675.							
p1676	Current setpoint filter 4 numerator damping	0.000	10.000	0.010	-	Float	IM	T, U
	Description: Sets the numerator damping for current setpoint filter 4.							
	Dependency: Current setpoint filter 4 is activated via p1656.3 and parameterized via p1673 ... p1675.							
p2153	Speed actual value filter time constant	0	1000000	0	ms	Float	IM	T, U
	Description: Sets the time constant of the PT1 element to smooth the speed/velocity actual value. The smoothed actual speed/velocity is compared with the threshold values and is only used for messages and signals.							
p2161 *	Speed threshold 3	0.00	210000.00	10.00	rpm	Float	IM	T, U
	Description: Sets the speed threshold value for the signal that indicates the axis is stationary.							
p2162 *	Hysteresis speed n_act > n_max	0.00	60000.00	0.00	rpm	Float	IM	T, U
	Description: Sets the hysteresis speed (bandwidth) for the signal "n_act > n_max".							

Par. No.	Name	Min	Max	Factory Setting	Unit	Data type	Effective	Can be changed
	<p>Note:</p> <p>For a negative speed limit, the hysteresis is effective below the limit value and for a positive speed limit above the limit value.</p> <p>If significant overshoot occurs in the maximum speed range (for example, due to load shedding), you are advised to increase the dynamic response of the speed controller (if possible). If this is insufficient, the hysteresis p2162 can be increased, but its value must not be greater than the value calculated by the formula below when the motor maximum speed is sufficiently greater than the maximum speed p1082.</p> $p2162 \leq 1.05 \times \text{motor maximum speed} - \text{maximum speed (p1082)}$ <p>The range of the parameter is different when connect with different motors.</p>							
p2175 *	Motor blocked speed threshold	0.00	210000.00	210000.00	rpm	Float	IM	T, U
	<p>Description: Sets the speed threshold for the message "Motor blocked".</p> <p>Dependency: Refer to p2177.</p>							
p2177 *	Motor blocked delay time	0.000	65.000	0.500	s	Float	IM	T, U
	<p>Description: Sets the delay time for the message "Motor blocked".</p> <p>Dependency: Refer to p2175.</p>							
p2525	LR encoder adjustment offset	0	4294967295	0	LU	U32	IM	T
	<p>Description: For the absolute encoder adjustment, a drive determines the position offset.</p> <p>Note: The position offset is only relevant for absolute encoders. The drive determines it when making the adjustment and the user should not change it.</p>							
p2533	LR position setpoint filter time constant	0.00	1000.00	0.00	ms	Float	IM	T, U
	<p>Description: Sets the time constant for the position setpoint filter (PT1).</p> <p>Note: The effective Kv factor (position loop gain) is reduced with the filter. This allows a softer control behavior with improved tolerance with respect to noise/disturbances.</p> <p>Applications:</p> <ul style="list-style-type: none"> - Reduces the pre-control dynamic response. - Jerk limiting. 							
p2542 *	LR standstill window	0	2147483647	1000	LU	U32	IM	T, U
	<p>Description: Sets the standstill window for the standstill monitoring function.</p> <p>After the standstill monitoring time expires, it is cyclically checked whether the difference between the setpoint and actual position is located within the standstill window and, if required, an appropriate fault is output.</p> <p>Value = 0: The standstill monitoring is deactivated.</p> <p>Dependency: Refer to: p2543, p2544, and F07450</p> <p>Note: The following applies for the setting of the standstill and positioning window: Standstill window (p2542) ≥ positioning window (p2544)</p>							
p2543 *	LR standstill monitoring time	0.00	100000.00	200.00	ms	Float	IM	T, U
	<p>Description: Sets the standstill monitoring time for the standstill monitoring function.</p> <p>After the standstill monitoring time expires, it is cyclically checked whether the difference between the setpoint and actual position is located within the standstill window and, if required, an appropriate fault is output.</p> <p>Dependency: Refer to: p2542, p2545, and F07450</p> <p>Note: The following applies for the setting of the standstill and positioning monitoring time: Standstill monitoring time (p2543) ≤ positioning monitoring time (p2545)</p>							

6.2 Parameter list

Par. No.	Name	Min	Max	Factory Setting	Unit	Data type	Effective	Can be changed
p2544 *	LR positioning window	0	2147483647	40	LU	U32	IM	T, U
	<p>Description: Sets the positioning window for the positioning monitoring function. After the positioning monitoring time expires, it is checked once as to whether the difference between the setpoint and actual position lies within the positioning window and if required an appropriate fault is output. Value = 0: The positioning monitoring function is de-activated.</p>							
	<p>Dependency: Refer to F07451.</p>							
	<p>Note: The following applies for the setting of the standstill and positioning window: Standstill window (p2542) \geq positioning window (p2544)</p>							
p2545 *	LR positioning monitoring time	0.00	100000.00	1000.00	ms	Float	IM	T, U
	<p>Description: Sets the positioning monitoring time for the positioning monitoring. After the positioning monitoring time expires, it is checked once as to whether the difference between the setpoint and actual position lies within the positioning window and if required an appropriate fault is output.</p>							
	<p>Dependency: The range of p2545 depends on p2543. Refer to: p2543, p2544, and F07451</p>							
	<p>Note: The tolerance bandwidth is intended to prevent the dynamic following error monitoring incorrectly responding due to operational control sequences (for example, during load surges).</p>							
p2546 *	LR dynamic following error monitoring tolerance	0	2147483647	3000/629146	LU	U32	IM	T, U
	<p>Description: Sets the tolerance for the dynamic following error monitoring. If the dynamic following error (r2563) exceeds the selected tolerance, then an appropriate fault is output. For a motor with an incremental encoder, the default value is 3000. For a motor with an absolute encoder, the default value is 629146. Value = 0: The dynamic following error monitoring is deactivated.</p>							
	<p>Dependency: Refer to r2563, F07452</p>							
	<p>Note: The tolerance bandwidth is intended to prevent the dynamic following error monitoring incorrectly responding due to operational control sequences (e.g. during load surges).</p>							
p2571	IPos maximum velocity	1	40000000	30000	1000 LU/min	U32	IM	T, U
	<p>Description: Sets the maximum velocity for the "basic positioner" function (IPos).</p>							
	<p>Note: The maximum velocity is active in all of the operating modes of the basic positioner. The maximum velocity for the basic positioner should be aligned with the maximum speed/velocity of the speed/velocity controller.</p>							
p2572 **	IPos maximum acceleration	1	2000000	Motor dependent	1000 LU/s ²	U32	IM	T
	<p>Description: Sets the maximum acceleration for the "basic positioner" function (IPos).</p>							
	<p>Note: The maximum acceleration appears to exhibit jumps (without jerk). "Traversing blocks" operating mode: The programmed acceleration override acts on the maximum acceleration. "Direct setpoint input/MDI" mode: The acceleration override is effective. "Jog" and "search for reference" modes: No acceleration override is active. The axis starts with the maximum acceleration.</p>							
p2573 **	IPos maximum deceleration	1	2000000	Motor dependent	1000 LU/s ²	U32	IM	T
	<p>Description: Sets the maximum deceleration for the "basic positioner" function (IPos).</p>							
	<p>Note: The maximum deceleration appears to exhibit jumps (without jerk). "Traversing blocks" operating mode:</p>							

Par. No.	Name	Min	Max	Factory Setting	Unit	Data type	Effective	Can be changed
	The programmed deceleration override acts on the maximum deceleration. "Direct setpoint input/MDI" mode: The deceleration override is effective. "Jog" and "search for reference" modes: No deceleration override is effective. The axis brakes with the maximum deceleration.							
p2574 **	IPos jerk limiting	1	100000000	10000	1000 LU/s ³	U32	IM	T, U
	Description: Sets the jerk limiting.							
	Dependency: Refer to p2572, p2573, and p2575							
	Note: The jerk limiting is internally converted into a jerk time as follows: Jerk time $T_r = \max(p2572, p2573)/p2574$							
p2575	IPos jerk limiting activation	0	1	0	-	U32	IM	T
	Description: Activates the jerk limiting. 0: The jerk limiting is deactivated. 1: The jerk limiting is activated.							
	Dependency: Refer to p2574							
p2580	EPOS software limit switch minus	-2147482648	2147482647	-2147482648	LU	I32	IM	T, U
	Description: Sets the software limit switch in the negative direction of travel.							
	Dependency: Refer to p2581, p2582							
p2581	EPOS software limit switch plus	-2147482648	2147482647	2147482647	LU	I32	IM	T, U
	Description: Sets the software limit switch in the positive direction of travel.							
	Dependency: Refer to p2580, p2582							
p2582	EPOS software limit switch activation	-	-	0	-	U32/ Binary	IM	T
	Description: Sets the signal source to activate the "software limit switch".							
	Dependency: Refer to p2580, p2581							
	Caution: Software limit switch effective: - Axis is referenced. Software limit switch ineffective: - Modulo correction active. - Search for reference is executed.							
	Notice: Target position for relative positioning outside software limit switch: The traversing block is started and the axis comes to a standstill at the software limit switch. An appropriate alarm is output and the traversing block is interrupted. Traversing blocks with valid position can be activated. Target position for absolute positioning outside software limit switch: In the "traversing blocks" mode, the traversing block is not started and an appropriate fault is output. Axis outside the valid traversing range: If the axis is already outside the valid traversing range, then an appropriate fault is output. The fault can be acknowledged at standstill. Traversing blocks with valid position can be activated.							
	Note: The traversing range can also be limited using STOP cams.							
p2583	EPOS backlash compensation	-200000	200000	0	LU	I32	IM	T, U
	Description: Sets the amount of play (backlash) for positive or negative play. = 0: The backlash compensation is deactivated. > 0: Positive backlash (normal case)							

6.2 Parameter list

Par. No.	Name	Min	Max	Factory Setting	Unit	Data type	Effective	Can be changed
	<p>When the direction is reversed, the encoder actual value leads the actual value. < 0: Negative backlash When the direction is reversed, the actual value leads the encoder actual value.</p> <p>Dependency: If a stationary axis is referenced by setting the reference point, or an adjusted with absolute encoder is powered up, then the setting of p2604 is relevant for entering the compensation value. p2604 = 1: Traveling in the positive direction -> A compensation value is immediately entered. Traveling in the negative direction -> A compensation value is not entered p2604 = 0: Traveling in the positive direction -> A compensation value is not entered Traveling in the negative direction -> A compensation value is immediately entered. When again setting the reference point (a referenced axis) or for "flying referencing", p2604 is not relevant but instead the history of the axis. Refer to: p2604</p>							
p2599	EPOS reference point coordinate value	-2147482648	2147482647	0	LU	I32	IM	T, U
	<p>Description: Sets the position value for the reference point coordinate. This value is set as the actual axis position after referencing or adjustment. Dependency: Refer to p2525</p>							
p2600	EPOS search for reference point offset	-2147482648	2147482647	0	LU	I32	IM	T, U
	<p>Description: Sets the reference point offset for search for reference.</p>							
p2604	EPOS search for reference start direction	-	-	0	-	U32/ Binary	IM	T
	<p>Description: Sets the signal sources for the start direction of the search for reference. 1 signal: Start in the negative direction. 0 signal: Start in the positive direction. Dependency: Refer to p2583</p>							
p2605	EPOS search for reference approach velocity reference cam	1	40000000	5000	1000 LU/min	U32	IM	T, U
	<p>Description: Sets the approach velocity to the reference cam for the search for reference. Dependency: The search for reference only starts with the approach velocity to the reference cam when there is a reference cam. Refer to p2604, p2606 Note: When traversing to the reference cam, the velocity override is effective. If, at the start of the search for reference, the axis is already at the reference cam, then the axis immediately starts to traverse to the zero mark.</p>							
p2606	EPOS search for reference reference cam maximum distance	0	2147482647	2147482647	LU	U32	IM	T, U
	<p>Description: Sets the maximum distance after the start of the search for reference when traversing to the reference cam. Dependency: Refer to p2604, p2605, F07458 Note: When using a reversing cam, the maximum distance must be set appropriately long.</p>							

Par. No.	Name	Min	Max	Factory Setting	Unit	Data type	Effective	Can be changed
p2608	EPOS search for reference approach velocity zero mark	1	40000000	300	1000 LU/min	U32	IM	T, U
	Description: Sets the approach velocity after detecting the reference cam to search for the zero mark for the search for reference.							
	Dependency: If there is no reference cam, the search for reference immediately starts with the axis traversing to the zero mark. Refer to p2604, p2609							
	Caution: If the reference cam is not adjusted so that at each search for reference the same zero mark for synchronization is detected, then an "incorrect" axis reference point is obtained. After the reference cam has been left, the search for the zero mark is activated with a time delay due to internal factors. This is the reason that the reference cam should be adjusted in this center between two zero marks and the approach velocity should be adapted to the distance between two zero marks. Note: The velocity override is not effective when traversing to the zero mark.							
p2609	EPOS search for reference max. distance ref. cam and zero mark	0	2147482647	20000	LU	U32	IM	T, U
	Description: Sets the maximum distance after leaving the reference cam when traversing to the zero mark. Dependency: Refer to p2604, p2608, F07459							
p2611	EPOS search for reference approach velocity reference point	1	40000000	300	1000 LU/min	U32	IM	T, U
	Description: Sets the approach velocity after detecting the zero mark to approach the reference point.							
	Dependency: Refer to p2604, p2609 Note: When traversing to the reference point, the velocity override is not effective.							
p2617[0...7]	EPOS traversing block position	-2147482648	2147482647	0	LU	I32	IM	T, U
	Description: Sets the target position for the traversing block.							
	Dependency: Refer to p2618 Note: The target position is approached in either relative or absolute terms depending on p29241.							
p2618[0...7]	EPOS traversing block velocity	1	40000000	600	1000 LU/min	I32	IM	T, U
	Description: Sets the velocity for the traversing block.							
	Dependency: Refer to p2617 Note: The velocity can be influenced using the velocity override.							
p2621[0...7]	Internal positioning task	1	2	1	-	I16	IM	T, U
	Description: Sets the required task for the traversing block. 1: POSITIONING 2: FIXED STOP							
	Dependency: Refer to: p2617, p2618							
p2634 *	Fixed stop maximum following error	0	2147482647	1000	LU	U32	IM	T, U
	Description: Sets the following error to detect the "fixed stop reached" state.							
	Dependency: Refer to: p2621 Note: The state "fixed stop reached" is detected if the following error exceeds the theoretically calculated following error value by p2634.							

6.2 Parameter list

Par. No.	Name	Min	Max	Factory Setting	Unit	Data type	Effective	Can be changed
p2635 *	Fixed stop monitoring window	0	2147482647	100	LU	U32	IM	T, U
	Description: Sets the monitoring window of the actual position after the fixed stop is reached.							
	Dependency: Refer to: F07484							
	Note: If, after the fixed stop is reached, the end stop shifts in either the positive or negative direction by more than the value set here, an appropriate message is output.							
p2692	MDI acceleration override, fixed setpoint	0.100	100.000	100.000	%	Float	IM	T, U
	Description: Sets a fixed setpoint for the acceleration override.							
	Note: The percentage value refers to the maximum acceleration (p2572).							
p2693	MDI deceleration override, fixed setpoint	0.100	100.000	100.000	%	Float	IM	T, U
	Description: Sets a fixed setpoint for the deceleration override.							
	Note: The percentage value refers to the maximum deceleration (p2573).							
p29000 *	Motor ID	0	65535	0	-	U16	IM	T
	Description: Motor type number is printed on the motor rating plate as motor ID. For a motor with an incremental encoder, users need to manually input the parameter value. For a motor with an absolute encoder, the drive automatically reads the parameter value.							
p29001	Reversal of motor direction	0	1	0	-	I16	IM	T
	Description: Reversal of motor running direction. By default, CW is the positive direction while CCW the negative direction. After changing of p29001, reference point will lost, A7461 will remind user to referencing again. 0: No reversal 1: Reverse							
p29002	BOP display selection	0	4	0	-	I16	IM	T, U
	Description: Selection of BOP operating display. 0: Actual speed (default) 1: DC voltage 2: Actual torque 3: Actual position 4: Position following error							
p29003	Control mode	0	8	0	-	I16	RE	T
	Description: Selection of control mode. 0: Position control with pulse train input (PTI) 1: Internal position control (IPos) 2: Speed control (S) 3: Torque control (T) 4: Control change mode: PTI/S 5: Control change mode: IPos/S 6: Control change mode: PTI/T 7: Control change mode: IPos/T 8: Control change mode: S/T							
	Note: The compound control mode can be controlled by the digital input signal C-MODE. When DI10 (C-MODE) is 0, the first control mode of control change mode is selected; otherwise, the second one is selected.							

Par. No.	Name	Min	Max	Factory Setting	Unit	Data type	Effective	Can be changed
p29004	RS485 address	1	31	1	-	U16	RE	T
	Description: Configuration of the RS485 bus address. The RS485 bus is used to transfer current absolute position of the servo drive to the controller/PLC. Note: Changes only become effective after power on. The parameter isn't influenced by default function.							
p29005	Braking resistor capacity percentage alarm threshold	1	100	100	%	Float	IM	T
	Description: Alarm triggering threshold for the capacity of the internal braking resistor. Alarm number: A52901							
p29006	Line supply voltage	200	480	400/230	V	U16	IM	T
	Description: Nominal Line supply voltage, effective value of line to line voltage. Drive can operate within -15% to +10% error. For V90 400 V variant, the value range is 380 V to 480 V, default value is 400 V. For V90 200 V variant, the value range is 200 V to 240 V, default value is 230 V.							
p29007	RS485 protocol	0	2	1	-	I16	RE	T
	Description: Set the communication protocol for the field bus interface: 0: No protocol 1: USS 2: Modbus Note: Changes only become effective after power on. The parameter isn't influenced by default function.							
p29008	Modbus control source	1	2	2	-	I16	RE	T
	Description: Select the Modbus control source: 1: Setpoint and control word from Modbus PZD 2: No control word No setpoint and control word from Modbus PZD Note: Changes only become effective after power on.							
p29009	RS485 baud rate	5	13	8	-	I16	RE	T
	Description: Set the baud rate for the RS485 interface: 5: 4800 baud 6: 9600 baud 7: 19200 baud 8: 38400 baud 9: 57600 baud 10: 76800 baud 11: 93750 baud 12: 115200 baud 13: 187500 baud Note: The change only becomes effective after power on. The parameter is not influenced by default function.							
p29010	PTI: Selection of input pulse form	0	3	0	-	U16	IM	T
	Description: Selection of setpoint pulse train input form. After changing of p29010, reference point will lost, A7461 will remind user to referencing again. 0: Pulse + direction, positive logic 1: AB phase, positive logic 2: Pulse + direction, negative logic 3: AB phase, negative logic							

6.2 Parameter list

Par. No.	Name	Min	Max	Factory Setting	Unit	Data type	Effective	Can be changed
p29011	PTI: Number of setpoint pulse per revolution	0	16777215	0	-	U32	IM	T
<p>Description: The number of setpoint pulses per motor revolution. The servo motor rotates for one revolution when the number of the setpoint pulses reaches this value.</p> <p>When this value is 0, the number of required setpoint pulses is decided by the electronic gear ratio.</p>								
p29012[0...3]	PTI: Numerator of electronic gear	1	10000	1	-	U32	IM	T
<p>Description: The numerator of the electronic gear ratio for the setpoint pulses. For the servo system with an absolute encoder, the value range of p29012 is 1 to 10000.</p> <p>Four numerators in total are available. You can select one of the numerators by configuring the digital input signal EGEAR.</p> <p>For detailed information about the calculation of a numerator, refer to the SINAMICS V90 Operating Instructions or use SINAMICS V-ASSISTANT to do the calculation.</p>								
p29013	PTI: Denominator of electronic gear	1	10000	1	-	U32	IM	T
<p>Description: The denominator of the electronic gear for the setpoint pulses.</p>								
p29014	PTI: Selection of pulse input electrical level	0	1	1	-	I16	IM	T
<p>Description: Selection of a logic level for the setpoint pulses.</p> <p>0: 5 V 1: 24 V</p>								
p29016	PTI: Pulse input filter	0	1	[0] 0	-	I16	IM	T
<p>Description: Select filter for PTI input to get better EMC performance, 0 for low frequency PTI input, 1 for high frequency PTI input.</p>								
p29019	RS485 monitor time	0	1999999	0	ms	Float	IM	T, U
<p>Description: Sets the monitoring time to monitor the process data received via the RS485 bus interface. If no process data is received within this time, then an appropriate message is output.</p> <p>Note: If p29019 = 0, monitoring is deactivated.</p>								
p29020[0...1]	Tuning: Dynamic factor	1	35	18	-	U16	IM	T, U
<p>Description: The dynamic factor of auto tuning. 35 dynamic factors in total are available.</p> <p>Index: [0]: Dynamic factor for one-button auto tuning [1]: Dynamic factor for real-time auto tuning</p>								
p29021	Tuning: Mode selection	0	5	0	-	I16	IM	T
<p>Description: Selection of a tuning mode.</p> <p>0: Disabled 1: One-button auto tuning 3: Real-time auto tuning 5: Disable with default controller parameters</p>								
p29022	Tuning: Ratio of total inertia moment to motor inertia moment	1.00	10000.00	1.00	-	Float	IM	T, U
<p>Description: Ratio of total inertia moment to servo motor inertia moment.</p>								

Par. No.	Name	Min	Max	Factory Setting	Unit	Data type	Effective	Can be changed
p29023	Tuning: One-button auto tuning configuration	0	0xffff	0x0007	-	U16	IM	T
<p>Description: One-button auto tuning configuration.</p> <p>Bit 0: The speed controller gain is determined and set using a noise signal.</p> <p>Bit 1: Possible required current setpoint filters are determined and set using a noise signal. As a consequence, a higher dynamic performance can be achieved in the speed control loop.</p> <p>Bit 2: The inertia moment ratio (p29022) can be measured after this function is running. If not set, the inertia moment ratio must be set manually with p29022.</p> <p>Bit 7: With this bit set, multi-axes are adapted to the dynamic response set in p29028. This is necessary for interpolating axes. The time in p29028 should be set according to the axis with the lowest dynamic response.</p>								
p29024	Tuning: Real-time auto tuning configuration	0	0xffff	0x004c	-	U16	IM	T
<p>Description: Real-time auto tuning configuration.</p> <p>Bit 2: The inertia moment ratio (p29022) is estimated while the motor is running, if not set, the inertia moment ratio must be set manually with p29022.</p> <p>Bit 3: If not set, the inertia moment ratio (p29022) is estimated only once and the inertia estimator is deactivated automatically after the estimation is completed. If the bit is set to 1, the inertia moment ratio is estimated in real time and the controller adapts the parameters continuously. You are recommended to save the parameters when the estimation result is satisfied. After that, when you power on the drive next time, the controller will be started with the optimized parameters.</p> <p>Bit 6: The adaption of current setpoint filter. This adaption may be necessary if a mechanical resonance frequency changes in operation. It can also be used to dampen a fixed resonance frequency. Once the control loop has stabilized, this bit should be deactivated and to save parameters in a non-volatile memory.</p> <p>Bit 7: With this bit set, multi-axes are adapted to the dynamic response set in p29028. This is necessary for interpolating axes. The time in p29028 should be set according to the axis with the lowest dynamic response.</p>								
p29025	Tuning: Configuration overall	0	0x003f	0x0004	-	U16	IM	T
<p>Description: Overall configuration of auto tuning, apply for both one-button and real-time auto tuning.</p> <p>Bit 0: For significant differences between the motor and load moment of inertia, or for low dynamic performance of the controller, then the P controller becomes a PD controller in the position control loop. As a consequence, the dynamic performance of the position controller is increased. This function should only be set when the speed pre-control (bit 3 = 1) or the torque pre-control (bit 4 = 1) is active.</p> <p>Bit 1: At low speeds, the controller gain factors are automatically reduced in order to avoid noise and oscillation at standstill. This setting is recommended for incremental encoders.</p> <p>Bit 2: The estimated load moment of inertia is taken into account for the speed controller gain.</p> <p>Bit 3: Activates the speed pre-control for the position controller.</p> <p>Bit 4: Activates the torque pre-control for the position controller.</p> <p>Bit 5: Adapts acceleration limit.</p> <p>Note:</p> <p>Speed pre-control</p> <p>The bit 3 of the p29025 will be set to 1 automatically after the factory default.</p> <p>You can set the bit 3 of p29025 manually in all control modes.</p> <p>Torque pre-control</p> <p>The bit 4 of p29025 will be set to 1 automatically if the following conditions are fulfilled simultaneously:</p> <p>Working with the 200 V drives</p> <p>Working in S control mode (p29003 = 2).</p>								

6.2 Parameter list

Par. No.	Name	Min	Max	Factory Setting	Unit	Data type	Effective	Can be changed
	The bit 4 of p29025 will not be set to 1 automatically if either of the following conditions is fulfilled: Working with the 400 V drives Working in all control modes except for the S controm mode (p29003 ≠ 2). You can set the bit 4 of p29025 manually in all control modes.							
p29026	Tuning: Test signal duration	0	5000	2000	ms	U32	IM	T
	Description: The duration time of the one-button auto tuning test signal.							
p29027	Tuning: Limit rotation of motor	0	30000	0	°	U32	IM	T
	Description: The limit position with motor rotations during one-button auto tuning. The traversing range is limited within +/- p29027 degrees (motor run one revolution is 360 degree).							
p29028	Tuning: Pre-control time constant	0.0	60.0	7.5	ms	Float	IM	T, U
	Description: Sets the time constant for the pre-control symmetrization for auto tuning. As a consequence, the drive is allocated a defined, dynamic response via its pre-control. For drives, which must interpolate with one another, the same value must be entered. The higher this time constant is, the smoother the drive will follow the position set point. Note: This time constant is only effective when multi-axis interpolation is selected (bit 7 of p29023 and p29024).							
p29030	PTO: Number of pulse per revolution	0, 30	16384	1000	-	U32	IM	T
	Description: Number of output pulses per motor revolution. If this value is 0, the number of required output pulses is decided by the electronic gear ratio.							
p29031	PTO: Numerator of electronic gear	1	2147000000	1	-	U32	IM	T
	Description: The numerator of the electronic gear ratio for the output pulses. For detailed information about the calculation of a numerator, refer to the SINAMICS V90 Operating Instructions or use the SINAMICS V-ASSISTANT to do the calculation.							
p29032	PTO: Denominator electronic gear	1	2147000000	1	-	U32	IM	T
	Description: The denominator of the electronic gear ratio for the output pulses. For detailed information about the calculation of a denominator, refer to the SINAMICS V90 Operating Instructions or use the SINAMICS V-ASSISTANT to do the calculation.							
p29033	PTO: Direction change	0	1	0	-	I16	IM	T
	Description: Select the PTO direction. 0: PTO positive PTO direction does not change. PTO A leads PTO B with 90 degrees when the motor rotates in clockwise direction. PTO B leads PTO A with 90 degrees when the motor rotates in counter-clockwise direction. 1: PTO negative PTO direction changes. PTO A leads PTO B with 90 degrees when the motor rotates in counter-clockwise direction. PTO B leads PTO A with 90 degrees when the motor rotates in clockwise direction.							
p29035	VIBSUP activation	0	1	0	-	I16	IM	T
	Description: Select the VIBSUP on/off. Position setpoint filter can be activated (p29035) for IPos control mode. 0: Disable Filter is not activated. 1: Enable Filter is activated.							

Par. No.	Name	Min	Max	Factory Setting	Unit	Data type	Effective	Can be changed
p29041[0...1]	Torque scaling	0	[0] 100 [1] 300	[0] 100 [1] 300	%	Float	IM	T
	<p>Description: [0]: The scaling for the analog torque setpoint. With this parameter, you can specify the torque setpoint corresponding to full analog input (10 V). [1]: The scaling for the analog torque limit. With this parameter, you can specify the torque limit corresponding to full analog input (10 V). You can select the internal parameters or the analog input as the source of the torque limit with the combination of the digital input signals TLIM1 and TLIM2.</p> <p>Index: [0]: Torque set scale [1]: Torque limit scale</p>							
p29042	Offset adjustment for analog input 2	-0.5000	0.5000	0.0000	V	Float	IM	T
	Description: Offset adjustment for the analog input 2.							
p29043	Fixed torque setpoint	-100	100	0	%	Float	IM	U, T
	<p>Description: Fixed torque setpoint. You can select the internal parameters or the analog input as the source of the torque setpoint by configuring the digital input signal TSET.</p>							
p29045	PTI: activate travel to fixed stop	0	1	0	-	I16	IM	T
	<p>Description: Activate/deactivate "travel to fixed stop" function under PTI control mode. 1: Travel to fixed stop is active 0: Travel to fixed stop is inactive</p>							
p29050[0...2]	Torque limit upper	-150	300	300	%	Float	IM	T
	<p>Description: Positive torque limit. Three internal torque limits in total are available. You can select the internal parameters or the analog input as the source of the torque limit with the combination of the digital input signals TLIM1 and TLIM2.</p>							
p29051[0...2]	Torque limit lower	-300	150	-300	%	Float	IM	T
	<p>Description: Negative torque limit. Three internal torque limits in total are available. You can select the internal parameters or the analog input as the source of the torque limit with the combination of the digital input signals TLIM1 and TLIM2.</p>							
p29060 *	Speed scaling	6	210000	3000	rpm	Float	IM	T
	<p>Description: The scaling for the analog speed setpoint. With this parameter, you can specify the speed setpoint corresponding to full analog input (10 V).</p>							
p29061	Offset adjustment for analog input 1	-0.5000	0.5000	0.0000	V	Float	IM	T
	Description: Offset adjustment for the analog input 1.							
p29070[0...2] *	Speed limit positive	0	210000	210000	rpm	Float	IM	T
	<p>Description: Positive speed limit. Three internal speed limits in total are available. You can select the internal parameters or the analog input as the source of the speed limit with the combination of the digital input signals SLIM1 and SLIM2.</p>							

6.2 Parameter list

Par. No.	Name	Min	Max	Factory Setting	Unit	Data type	Effective	Can be changed
p29071[0...2] *	Speed limit negative	-210000	0	-210000	rpm	Float	IM	T
	Description: Negative speed limit. Three internal speed limits in total are available. You can select the internal parameters or the analog input as the source of the speed limit with the combination of the digital input signals SLIM1 and SLIM2.							
p29075	Speed clamp threshold	0	200	200	rpm	Float	IM	T
	Description: The threshold for the zero speed clamp. If the function of zero speed clamp has been enabled under the speed control mode, the motor speed is clamped to 0 when both the setpoint speed and the actual speed are below this threshold.							
p29078	Speed reach threshold	0.0	100.0	10	rpm	Float	IM	T
	Description: Speed reached range (deviation between setpoint and motor speed)							
p29080	Overload threshold for output signal triggering	10	300	100	%	Float	IM	T
	Description: Overload threshold for the output power.							
p29090	Offset Adjustment for Analog output 1	-0.50	0.50	0.00	V	Float	IM	T
	Description: Offset adjustment for analog output 1.							
p29091	Offset adjustment for analog output 2	-0.50	0.50	0.00	V	Float	IM	T
	Description: Offset adjustment for analog output 2.							
p29110[0...1] **	Position loop gain	0.000	300.000	[0] Motor dependent [1] 1.000	1000/min	Float	IM	T, U
	Description: Position loop gain. Two position loop gains in total are available. You can switch between these two gains by configuring the digital input signal G-CHANGE or setting relevant condition parameters. The first position loop gain is the default setting.							
	Dependency: The parameter value will be set to default after configuring a new motor ID (p29000).							
p29111	Speed pre-control factor (feed forward)	0.00	200.00	0.00	%	Float	IM	T, U
	Description: Setting to activate and weight the speed pre-control value. Value = 0%: The pre-control is deactivated.							
p29120[0...1] **	Speed loop gain	0.00	999999.00	[0] Motor dependent [1] 0.30	Nms/rad	Float	IM	T, U
	Description: Speed loop gain. Two speed loop gains in total are available. You can switch between these two gains by configuring the digital input signal G-CHANGE or setting relevant condition parameters. The first speed loop gain is the default setting.							
	Dependency: The parameter value will be set to default after configuring a new motor ID (p29000).							
p29121[0...1] *	Speed loop integral time	0.00	100000.00	[0] 15 [1] 20	ms	Float	IM	T, U
	Description: Speed loop integral time. Two speed loop integral time values in total are available. You can switch between these two time values by configuring the digital input signal G-CHANGE or setting relevant condition parameters. The first speed loop integral time is the default setting.							
	Dependency: The parameter value will be set to default after configuring a new motor ID (p29000).							

Par. No.	Name	Min	Max	Factory Setting	Unit	Data type	Effective	Can be changed
p29130	Gain switching: Mode selection	0	4	0	-	I16	IM	T
	<p>Description: Selects gain switching mode.</p> <p>0: Disabled</p> <p>1: Switch through DI-G-CHANG</p> <p>2: Position deviation as switch condition</p> <p>3: Pulse input frequency as switch condition</p> <p>4: Actual speed as switch condition</p> <p>Note: Only when the auto tuning function (p20021=0) is disabled can the gain switching function be used.</p>							
p29131	Gain switching condition: Pulse deviation	0	2147483647	100	LU	I32	IM	T
	<p>Description: Triggers position deviation threshold for gain switching. If the gain switching function is enabled and this condition is selected:</p> <p>Switch from the first group of control parameters to the second group when the position deviation is larger than the threshold.</p> <p>Switch from the second group of control parameters to the first group when the position deviation is smaller than the threshold.</p>							
p29132	Gain switching condition: Position setpoint frequency	0	2147000064	100	1000 LU/min	Float	IM	T
	<p>Description: Triggers pulse input frequency (PTI) threshold or internal position speed (IPos) threshold for gain switching. If the gain switching function is enabled and this condition is selected:</p> <p>PTI</p> <p>Switch from the first group of control parameters to the second group when the pulse train input pulse is higher than the threshold.</p> <p>Switch from the second group of control parameters to the first group when the pulse train input is lower than the threshold.</p> <p>IPos</p> <p>Switch from the first group of control parameters to the second group when the speed of fixed position setpoint is larger than the threshold.</p> <p>Switch from the second group of control parameters to the first group when the IPos is smaller than the threshold.</p>							
p29133	Gain switching condition: Actual speed	0	2147000064	100	rpm	Float	IM	T
	<p>Description: Triggers speed threshold for gain switching. If the gain switching function is enabled and this condition is selected:</p> <p>Switch from the first group of control parameters to the second group when the actual motor speed is larger than the threshold.</p> <p>Switch from the second group of control parameters to the first group when the actual motor speed is smaller than the threshold.</p>							
p29139	Gain switching time constant	8	1000	20	ms	Float	IM	T
	<p>Description: Time constant for gain switching. Set this parameter to avoid frequent gain switches that reduces system reliability.</p>							
p29140	PI to P: Mode selection	0	5	0	-	U16	IM	T
	<p>Description: Selects a condition for the switch from PI control to P control under the speed loop.</p> <p>0: Disabled</p> <p>1: Torque is higher than a parameterizable setting value.</p> <p>2: Using the digital input signal (G-CHANGE).</p>							

6.2 Parameter list

Par. No.	Name	Min	Max	Factory Setting	Unit	Data type	Effective	Can be changed
	3: Speed is higher than a parameterizable setting value. 4: Acceleration is higher than a parameterizable setting value. 5: Pulse deviation is higher than a parameterizable setting value. Note: Only when the auto tuning function (p29021=0) and gain switching function are both disabled can the PI/P switching function be used.							
p29141	PI to P switching condition: Torque	0	300	200	%	Float	IM	T
	Description: Triggers torque threshold for PI/P switching. If the PI/P switching function is enabled and this condition is selected: Switch from the PI control to the P control when the actual torque is larger than the threshold. Switch from the P control to the PI control when the actual torque is smaller than the threshold.							
p29142	PI to P switching condition: Speed	0	210000	2000	rpm	Float	IM	T
	Description: Triggers speed threshold for PI/P switching. If the PI/P switching function is enabled and this condition is selected: Switch from the PI control to the P control when the actual speed is larger than the threshold. Switch from the P control to the PI control when the actual speed is smaller than the threshold.							
p29143	PI to P switching condition: Acceleration	0	30000	20	rev/s ²	Float	IM	T
	Description: Triggers acceleration threshold for PI/P switching. If the PI/P switching function is enabled and this condition is selected: Switch from the PI control to the P control when the actual acceleration is larger than the threshold. Switch from the P control to the PI control when the actual acceleration is smaller than the threshold.							
p29144	PI to P switching condition: Pulse deviation	0	2147483647	30000	LU	U32	IM	T
	Description: Triggers pulse deviation threshold for PI/P switching. If the PI/P switching function is enabled and this condition is selected: Switch from the PI control to the P control when the actual pulse deviation is larger than the threshold. Switch from the P control to the PI control when the actual pulse deviation is smaller than the threshold.							
p29230	MDI direction selection	0	2	0	-	I16	IM	T
	Description: MDI direction selection: 0: Absolute positioning through the shortest distance 1: Absolute positioning through the positive direction 2: Absolute positioning through the negative direction							
p29240	Select referencing mode	0	4	1	-	I16	IM	T
	Description: Selects referencing mode. 0: Referencing with external signal REF 1: Referencing with external reference cam (signal REF) and encoder zero mark 2: Referencing with zero mark only 3: Referencing with external reference cam (CCWL) and zero mark 4: Referencing with external reference cam (CWL) and zero mark							
p29241	Positioning mode selection	0	3	0	-	U16	IM	T
	Description: Moves mode set for IPos: 0: Means relative moving 1: Means abs moving 2: POS Mod 3: NEG Mod							

Par. No.	Name	Min	Max	Factory Setting	Unit	Data type	Effective	Can be changed
p29242	CLR pulse mode	0	2	0	-	U16	IM	T
	Description: Select clear pulse mode 0: Disabled 1: Means clear pulse on high level 2: Means clear pulse on rising edge							
p29243	Positioning tracking activate	0	1	0	-	I16	IM	T
	Description: Activation of position tracking. 0: Deactivated 1: Activated							
p29244	Absolute encoder virtual rotary revolutions	0	4096	0	-	U32	IM	T
	Description: Sets the number of rotations that can be resolved for an encoder with activated position tracking function (p29243 = 1).							
p29245	Axis mode state	0	1	0	-	U32	IM	T
	Description: Linear/modulo mode: 0: Linear axis 1: Modulo axis							
p29246 *	Modulo correction range	1	2147482647	360000	LU	U32	IM	T
	Description: Sets the modulo range for axes with modulo correction.							
p29247 *	Mechanical gear: LU per revolution	1	2147483647	10000	-	U32	IM	T
	Description: LU per load revolution.							
p29248 *	Mechanical gear: Numerator	1	1048576	1	-	U32	IM	T
	Description: (Load/Motor) Load revolutions.							
p29249 *	Mechanical gear: denominator	1	1048576	1	-	U32	IM	T
	Description: (Load/Motor) Motor revolutions.							
p29250	PTI absolute position mode enable	0	1	0	-	U32	RE	T
	Description: Absolute position mode enable. 1: Enable Absolute Mode 0: Disable Absolute Mode							
p29300	Digital input forced signals	0	127	0	-	U32	IM	T, U
	Description: assignment signals are forced to be high. 7 bits in total. Bit 0: SON Bit 1: CWL Bit 2: CCWL Bit 3: TLIM1 Bit 4: SPD1 Bit 5: TSET Bit 6: EMGS If one or more bits are set to be high, the corresponding input signals are forced to be logical high signals.							
	Note: The drive unit displays the value in hex format. To know the logic (high/low) assignment to each bit, you must convert the hex number to the binary number, for example, FF (hex) = 11111111 (bin).							

6.2 Parameter list

Par. No.	Name	Min	Max	Factory Setting	Unit	Data type	Effective	Can be changed
p29301[0...3]	Digital input 1 assignment	0	28	1	-	I16	IM	T
<p>Description: Defines the function of digital input signal DI1 (PTI mode)</p> <p>1: SON 2: RESET 3: CWL 4: CCWL 5: G-CHANGE 6: P-TRG 7: CLR 8: EGEAR1 9: EGEAR2 10: TLIM1 11: TLIM2 12: CWE 13: CCWE 14: ZSCLAMP 15: SPD1 16: SPD2 17: SPD3 18: TSET 19: SLIM1 20: SLIM2 21: POS1 22: POS2 23: POS3 24: REF 25: SREF 26: STEPF 27: STEPB 28: STEPH</p> <p>Index: [0]: DI1 for control mode 0 [1]: DI1 for control mode 1 [2]: DI1 for control mode 2 [3]: DI1 for control mode 3</p>								
p29302[0...3]	Digital input 2 assignment	0	28	2	-	I16	IM	T
<p>Description: Defines the function of digital input signal DI2</p> <p>Index: [0]: DI2 for control mode 0 [1]: DI2 for control mode 1 [2]: DI2 for control mode 2 [3]: DI2 for control mode 3</p>								

Par. No.	Name	Min	Max	Factory Setting	Unit	Data type	Effective	Can be changed
p29303[0...3]	Digital input 3 assignment	0	28	3	-	I16	IM	T
	Description: Defines the function of digital input signal DI3							
	Index: [0]: DI3 for control mode 0 [1]: DI3 for control mode 1 [2]: DI3 for control mode 2 [3]: DI3 for control mode 3							
p29304[0...3]	Digital input 4 assignment	0	28	4	-	I16	IM	T
	Description: Defines the function of digital input signal DI4							
	Index: [0]: DI4 for control mode 0 [1]: DI4 for control mode 1 [2]: DI4 for control mode 2 [3]: DI4 for control mode 3							
p29305[0...3]	Digital input 5 assignment	0	28	[0] 5; [1] 5; [2] 12; [3] 12	-	I16	IM	T
	Description: Defines the function of digital input signal DI5							
	Index: [0]: DI5 for control mode 0 [1]: DI5 for control mode 1 [2]: DI5 for control mode 2 [3]: DI5 for control mode 3							
p29306[0...3]	Digital input 6 assignment	0	28	[0] 6; [1] 6; [2] 13; [3] 13	-	I16	IM	T
	Description: Defines the function of digital input signal DI6							
	Index: [0]: DI6 for control mode 0 [1]: DI6 for control mode 1 [2]: DI6 for control mode 2 [3]: DI6 for control mode 3							
p29307[0...3]	Digital input 7 assignment	0	28	[0] 7; [1] 21; [2] 15; [3] 18	-	I16	IM	T
	Description: Defines the function of digital input signal DI7							
	Index: [0]: DI7 for control mode 0 [1]: DI7 for control mode 1 [2]: DI7 for control mode 2 [3]: DI7 for control mode 3							

Parameters

6.2 Parameter list

Par. No.	Name	Min	Max	Factory Setting	Unit	Data type	Effective	Can be changed
p29308[0...3]	Digital input 8 assignment	0	28	[0] 10; [1] 22; [2] 16; [3] 19	-	I16	IM	T
	Description: Defines the function of digital input signal DI8 Index: [0]: DI8 for control mode 0 [1]: DI8 for control mode 1 [2]: DI8 for control mode 2 [3]: DI8 for control mode 3							
p29330	Digital output 1 assignment	1	15	1	-	I16	IM	T
	Description: Defines the function of digital output signal DO1 1: RDY 2: FAULT 3: INP 4: ZSP 5: SPDR 6: TLR 7: SPLR 8: MBR 9: OLL 10: WARNING1 11: WARNING2 12: REFOK 13: CM_STA 14: RDY_ON 15: STO_EP							
p29331	Digital output 2 assignment	1	15	2	-	I16	IM	T
	Description: Defines the function of digital output signal DO2							
p29332	Digital output 3 assignment	1	15	3	-	I16	IM	T
	Description: Defines the function of digital output signal DO3							
p29333	Digital output 4 assignment	1	15	5	-	I16	IM	T
	Description: Defines the function of digital output signal DO4							
p29334	Digital output 5 assignment	1	15	6	-	I16	IM	T
	Description: Defines the function of digital output signal DO5							
p29335	Digital output 6 assignment	1	15	8	-	I16	IM	T
	Description: Defines the function of digital output signal DO6							
p29340	Warning 1 assigned for digital output	1	6	1	-	U16	IM	T
	Description: Defines conditions for WRN1.							

Par. No.	Name	Min	Max	Factory Setting	Unit	Data type	Effective	Can be changed
	1: Motor overload protection warning: 85% of overload threshold has been reached. 2: Holding brake power overload warning: threshold p29005 has been reached. 3: Fan warning: fan has stopped for more than 1 s. 4: Encoder warning 5: Motor overtemperature warning: 85% of overtemperature threshold has been reached. 6: Capacitor service life warning: The capacitor has reached its expiry, so replace it.							
p29341	Warning 2 assigned for digital output	1	6	2	-	U16	IM	T
	Description: Defines conditions for WARNING2. 1: Motor overload protection warning: 85% of overload threshold has been reached. 2: Holding brake power overload warning: threshold p29005 has been reached. 3: Fan warning: life time of fan expired (40000 hours), replacement of fan needed. 4: Encoder warning 5: Motor overtemperature warning: 85% of overtemperature threshold has been reached. 6: Capacitor service life warning: The capacitor has reached its expiry, so replace it.							
p29350	Select sources for analog output 1	0	12	0	-	U16	IM	T
	Description: Selects signal source for analog output 1. 0: Actual speed (reference p29060) 1: Actual torque (reference 3 × r0333) 2: Speed setpoint (reference p29060) 3: Torque setpoint (reference 3 × r0333) 4: DC bus voltage (reference 1000 V) 5: Pulse input frequency (reference 1k) 6: Pulse input frequency (reference 10k) 7: Pulse input frequency (reference 100k) 8: Pulse input frequency (reference 1000k) 9: Remaining number of pulses (reference 1k) 10: Remaining number of pulses (reference 10k) 11: Remaining number of pulses (reference 100k) 12: Remaining number of pulses (reference 1000k)							
p29351	Select signal source for analog 2	0	12	1	-	U16	IM	T
	Description: Selects signals for analog output 2. 0: Actual speed (reference p29060) 1: Actual torque (reference 3 × r0333) 2: Speed setpoint (reference p29060) 3: Torque setpoint (reference 3 × r0333) 4: DC bus voltage (reference 1000 V) 5: Pulse input frequency (reference 1k)							

6.2 Parameter list

Par. No.	Name	Min	Max	Factory Setting	Unit	Data type	Effective	Can be changed
	6: Pulse input frequency (reference 10k) 7: Pulse input frequency (reference 100k) 8: Pulse input frequency (reference 1000k) 9: Remaining number of pulses (reference 1k) 10: Remaining number of pulses (reference 10k) 11: Remaining number of pulses (reference 100k) 12: Remaining number of pulses (reference 1000k)							
p29360	Brake resistor alarm active	0	1	1	-	I16		
	Description: Configure the deactivation of the brake resistor alarm. 0: A52901 monitor is activated. 1: A52901 monitor is deactivated.							
p31581	VIBSUP: Filter type	0	1	0	-	I16	IM	T
	Description: Sets the filter type for VIBSUP. Depending on the selected filter type, the VIBSUP filter results in motion sequences that take somewhat longer. 0: The rugged VIBSUP filter has a lower sensitivity to frequency offsets compared with the sensitive filter type, but results in a higher delay of the motion sequence. The total motion sequence is extended by the time period T_d ($T_d = 1/f_d$). 1: The sensitive VIBSUP filter has a higher sensitivity to frequency offsets compared with the rugged filter type, but results in a lower delay of the motion sequence. The total motion sequence is extended by half the time period $T_d/2$ ($T_d = 1/f_d$).							
p31585	VIBSUP: Filter frequency f_d	0.5	62.5	1	Hz	Float 32	IM	T
	Description: Sets the frequency of the damped natural vibration of the mechanical system. This frequency can be determined by making the appropriate measurements. Note: The maximum frequency that can be set depends on the filter sampling time.							
p31586	VIBSUP: Filter damping	0.00	0.99	0.03	-	Float 32	IM	T
	Description: Sets the value for the damping of the natural mechanical vibration to be filtered. Typically, the damping value is about 0.03, and can be optimized by performing the appropriate positioning tests.							

Read-only parameters

Par. No.	Name	Unit	Data type
r0020	Speed setpoint smoothed	rpm	Float
	Description: Displays the currently smoothed speed setpoint at the input of the speed controller or U/f characteristic (after the interpolator).		
	Note: Smoothing time constant = 100 ms The signal is not suitable as a process quantity and may only be used as a display quantity. The speed setpoint is available smoothed (r0020) and unsmoothed.		
r0021	Actual speed smoothed	rpm	Float
	Description: Displays the smoothed actual value of the motor speed.		
	Note: Smoothing time constant = 100 ms The signal is not suitable as a process quantity and may only be used as a display quantity. The speed actual value is available smoothed (r0021) and unsmoothed.		
r0026	DC link voltage smoothed	V	Float
	Description: Displays the smoothed actual value of the DC link voltage.		
	Note: Smoothing time constant = 100 ms The signal is not suitable as a process quantity and may only be used as a display quantity. The DC link voltage is available smoothed.		
r0027	Absolute actual current smoothed	Arms	Float
	Description: Displays the smoothed absolute actual current value.		
	Notice: This smoothed signal is not suitable for diagnostics or evaluation of dynamic operations. In this case, the unsmoothed value should be used.		
	Note: Smoothing time constant = 100 ms The signal is not suitable as a process quantity and may only be used as a display quantity. The absolute current actual value is available smoothed (r0027) and unsmoothed.		
r0029	Current actual value field-generating smoothed	Arms	Float
	Description: Displays the smoothed field-generating actual current.		
	Note: Smoothing time constant = 100 ms The signal is not suitable as a process quantity and may only be used as a display quantity. The field-generating current actual value is available smoothed (r0029) and unsmoothed.		
r0030	Current actual value torque-generating smoothed	Arms	Float
	Description: Displays the smoothed torque-generating actual current.		
	Note: Smoothing time constant = 100 ms The signal is not suitable as a process quantity and may only be used as a display quantity. The torque-generating current actual value is available smoothed.		
r0031	Actual torque smoothed	Nm	Float
	Description: Displays the smoothed torque actual value.		
	Note: Smoothing time constant = 100 ms The signal is not suitable as a process quantity and may only be used as a display quantity. The torque actual value is available smoothed (r0031) and unsmoothed.		

6.2 Parameter list

Par. No.	Name	Unit	Data type
r0032	Active power actual value smoothed	kW	Float
	Description: Displays the smoothed actual value of the active power.		
r0033	Torque utilization smoothed	%	Float
	Description: Displays the smoothed torque utilization as a percentage. The torque utilization is obtained from the required smoothed torque in reference to the torque limit, scaled using p2196.		
	Note: Smoothing time constant = 100 ms The signal is not suitable as a process quantity and may only be used as a display quantity. The torque utilization is available smoothed (r0033) and unsmoothed. For M_set total (r0079) > M_max offset, the following applies: <ul style="list-style-type: none"> • demanded torque = M_set total - M_max offset • actual torque limit = M_max upper effective - M_max offset For M_set total (r0079) ≤ M_max offset (p1532), the following applies: <ul style="list-style-type: none"> • demanded torque = M_max offset - M_set total • actual torque limit = M_max offset - M_max lower effective For the actual torque limit = 0, the following applies: r0033 = 100 % For the actual torque limit < 0, the following applies: r0033 = 0 %		
r0034	Motor utilization thermal	%	Float
	Description: Displays the motor utilization from motor temperature model 1 (I ^{2t}) or 3.		
r0037[0...19]	Power unit temperatures	°C	Float
	Description: Displays the temperatures in the power unit.		
	Index: <ul style="list-style-type: none"> • [0]: Inverter maximum value • [1]: Depletion layer maximum value • [2]: Rectifier maximum value • [3]: Air intake • [4]: Interior of power unit • [5]: Inverter 1 • [6]: Inverter 2 • [7]: Inverter 3 • [8]: Inverter 4 • [9]: Inverter 5 • [10]: Inverter 6 • [11]: Rectifier 1 • [12]: Rectifier 2 • [13]: Depletion layer 1 • [14]: Depletion layer 2 • [15]: Depletion layer 3 • [16]: Depletion layer 4 • [17]: Depletion layer 5 • [18]: Depletion layer 6 • [19]: Cooling unit liquid intake 		
	Dependency: Refer to A01009		
	Notice: Only for internal Siemens troubleshooting.		

Par. No.	Name	Unit	Data type
	<p>Note: The value of -200 indicates that there is no measuring signal.</p> <ul style="list-style-type: none"> r0037[0]: Maximum value of the inverter temperatures (r0037[5...10]). r0037[1]: Maximum value of the depletion layer temperatures (r0037[13...18]). r0037[2]: Maximum value of the rectifier temperatures (r0037[11...12]). <p>The maximum value is the temperature of the hottest inverter, depletion layer, or rectifier.</p>		
r0079[0...1]	Torque setpoint total	Nm	Float
	<p>Description: Displays and connector output for the torque setpoint at the output of the speed controller (before clock cycle interpolation).</p> <p>Index:</p> <ul style="list-style-type: none"> [0]: Unsmoothed [1]: Smoothed 		
r0296	DC link voltage undervoltage threshold	V	U16
	<p>Description: Threshold to detect a DC link undervoltage. If the DC link voltage falls below this threshold, the drive unit is tripped due to a DC link undervoltage condition.</p> <p>Note: The value depends on the device type and the selected device rated voltage.</p>		
r0297	DC link voltage overvoltage threshold	V	U16
	<p>Description: If the DC link voltage exceeds the threshold specified here, the drive unit is tripped due to DC link overvoltage.</p> <p>Dependency: Refer to F30002.</p>		
r0311	Rated motor speed	rpm	Float
	<p>Description: Displays the rated motor speed (rating plate).</p>		
r0333	Rated motor torque	Nm	Float
	<p>Description: Displays the rated motor torque. IEC drive: unit Nm NEMA drive: unit lbf ft</p>		
r0482[0...2]	Encoder actual position value Gn_XIST1	-	U32
	<p>Description: Displays the encoder actual position value Gn_XIST1.</p> <p>Index:</p> <ul style="list-style-type: none"> [0]: Encoder 1 [1]: Encoder 2 [2]: Reserved <p>Note:</p> <ul style="list-style-type: none"> In this value, the measuring gear is only taken into account when the position tracking is activated. The update time for the position control (EPOS) corresponds to the position controller clock cycle. The update time in isochronous operation corresponds to the bus cycle time. The update time in isochronous operation and with position control (EPOS) corresponds to the position controller clock cycle. The update time in non-isochronous operation or without position control (EPOS) comprises the following: <ul style="list-style-type: none"> Update time = 4 * least common multiple (LCM) of all current controller clock cycles in the drive group (infeed + drives). The minimum update time is 1 ms. Example 1: infeed, servo Update time = 4 * LCM(250 μs, 125 μs) = 4 * 250 μs = 1 ms Example 2: infeed, servo, vector Update time = 4 * LCM(250 μs, 125 μs, 500 μs) = 4 * 500 μs = 2 ms 		

6.2 Parameter list

Par. No.	Name	Unit	Data type
r0632	Motor temperature model, stator winding temperature	°C	Float
	Description: Displays the stator winding temperature of the motor temperature model.		
r0722	CU digital inputs status	-	U32
	Description: Displays the status of the digital inputs.		
	Note: DI: Digital input DI/DO: Bidirectional digital input/output The drive unit displays the value in hex format. You can convert the hex number to the binary number, for example, FF (hex) = 11111111 (bin).		
r0747	CU digital outputs status	-	U32
	Description: Displays the status of digital outputs.		
	Note: DI/DO: Bidirectional digital input/output The drive unit displays the value in hex format. You can convert the hex number to the binary number, for example, FF (hex) = 11111111 (bin).		
r0807.0	Master control active	-	U8
	Description: Displays what has the master control. The drive can be controlled via the internal interconnection or from external.		
r0945[0...63]	Fault code	-	U16
	Description: Displays the number of faults that have occurred.		
	Dependency: Refer to r0949		
	Note: The buffer parameters are cyclically updated in the background. Fault buffer structure (general principle): r0945[0], r0949[0] → actual fault case, fault 1 ... r0945[7], r0949[7] → actual fault case, fault 8 r0945[8], r0949[8] → 1st acknowledged fault case, fault 1 ... r0945[15], r0949[15] → 1st acknowledged fault case, fault 8 ... r0945[56], r0949[56] → 7th acknowledged fault case, fault 1 ... r0945[63], r0949[63] → 7th acknowledged fault case, fault 8		
r0949[0...63]	Fault value	-	I32
	Description: Displays additional information about the fault that occurred (as integer number).		
	Dependency: Refer to r0945		
	Note: The buffer parameters are cyclically updated in the background. The structure of the fault buffer and the assignment of the indices is shown in r0945.		
r2050 [0...19]	MODBUS PZD receive word	-	I16
	Description: Modbus PZD (setpoints) with word format received from the host controller.		
	Index: Index 0 to index 19 stand for PZD1 to PZD20 correspondingly. <ul style="list-style-type: none"> • [0]: Control word from host controller, the definition of control word refer to r2090. • [1]: In speed control mode, means speed setpoint from host controller. • [2] and [3]: In internal position control mode, means position setpoint(Hword/Lword) from host controller • [4] to [19]: Reserved. 		

Par. No.	Name	Unit	Data type
r2090.0...15	MODBUS PZD1 receive bit-serial	-	U16
	Description: Bit-serial description of PZD1 (normally control word 1) received from the host controller. If the value of the bit equals to 0, it means the function of this bit is deactivated. If the value of the bit equals to 1, it means the function of this bit is activated.		
r2122[0...63]	Alarm code	-	U16
	Description: Displays the number of faults that have occurred.		
	Dependency: Refer to r2124		
	Note: The buffer parameters are cyclically updated in the background. Alarm buffer structure (general principle): r2122[0], r2124[0] → alarm 1 (the oldest) ... r2122[7], r2124[7] → alarm 8 (the latest) When the alarm buffer is full, the alarms that have gone are entered into the alarm history: r2122[8], r2124[8] → alarm 1 (the latest) ... r2122[63], r2124[63] → alarm 1 (the oldest)		
r2124[0...63]	Alarm value	-	I32
	Description: Displays additional information about the active alarm (as integer number).		
	Dependency: Refer to r2124		
	Note: The buffer parameters are cyclically updated in the background. The structure of the alarm buffer and the assignment of the indices is shown in r2122.		
r2521[0...3]	LR position actual value	LU	I32
	Description: Displays the actual position actual value determined by the position actual value preprocessing. Index: <ul style="list-style-type: none"> • [0]: CI-loop position control • [1]: Encoder 1 • [2]: Encoder 2 • [3]: Reserved 		
r2522[0...3]	LR velocity actual value	1000 LU/min	I32
	Description: Displays the actual position actual value determined by the velocity actual value preprocessing. Index: <ul style="list-style-type: none"> • [0]: CI-loop position control • [1]: Encoder 1 • [2]: Encoder 2 • [3]: Reserved 		
r2556	LR position setpoint after setpoint smoothing	LU	I32
Description: Display and connector output for the position setpoint after setpoint smoothing.			
r2563	LR following error dynamic model	LU	I32
	Description: Displays the dynamic following error. This value is the deviation, corrected by the velocity-dependent component, between the position setpoint and the position actual value.		

Parameters

6.2 Parameter list

Par. No.	Name	Unit	Data type
r2665	EPOS position setpoint	LU	I32
	Description: Displays the actual absolute position setpoint.		
r29015	PTI: Pulse input frequency	Hz	Float
	Description: Displays the PTI input pulse frequency.		
r29018[0...1]	OA version	-	Float
	Description: Displays the OA version.		
	Index: <ul style="list-style-type: none"> • [0]: Firmware version • [1]: Build increment number 		
r29400	Internal control signal status indicating	-	U32
	Description: Control signal status identifiers Bit 0 SON, Bit 1 RESET, Bit 2 CWL, Bit 3 CCWL, Bit 4 G-CHANGE, Bit 5 P-TRG, Bit 6 CLR, Bit 7 EGEAR1, Bit 8 EGEAR2, Bit 9 TLIM1, Bit 10 TLIM2, Bit 11 CWE, Bit 12 CCWE, Bit 13 ZSCLAMP, Bit 14 SPD1, Bit 15 SPD2, Bit 16 SPD3, Bit 17 TSET, Bit 18 SLIM1, Bit 19 SLIM2, Bit 20 POS1, Bit 21 POS2, Bit 22 POS3, Bit 23 REF, Bit 24 SREF, Bit 25 STEPFB, Bit 26 STEPB, Bit 27 STEPH, Bit 28 EMGS, Bit 29 C-MODE		
r29942	DO signals status indicating	-	U32
	Description: Indicates the status of DO signals. <ul style="list-style-type: none"> • Bit 0: RDY • Bit 1: FAULT • Bit 2: INP • Bit 3: ZSP • Bit 4: SPDR • Bit 5: TLR • Bit 6: SPLR • Bit 7: MBR • Bit 8: OLL • Bit 9: WARNING1 • Bit 10: WARNING2 • Bit 11: REFOK • Bit 12: CM_STA • Bit 13: RDY_ON • Bit 14: STO_EP 		
r29979	Index of actual electronic gear	-	U32
	Description: Displays the status of position loop. <ul style="list-style-type: none"> • Bit 0 to Bit 1: Actual EGear index 		

Diagnostics

7.1 Overview

General information about faults and alarms







The errors and states detected by the individual components of the drive system are indicated by messages.

The messages are categorized into faults and alarms.

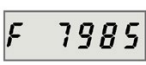
Properties of faults and alarms

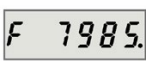
- Faults
 - Are identified by Fxxxxx.
 - Can lead to a fault reaction.
 - Must be acknowledged once the cause has been remedied.
 - Status via control unit and LED RDY.
 - Status via MODBUS status word PZD1.1 (fault status).
 - Entry in the fault buffer.
- Alarms
 - Are identified by Axxxxx.
 - Have no further effect on the drive.
 - The alarms are automatically reset once the cause has been remedied. No acknowledgement is required.
 - Status via Control Unit and LED RDY.
 - Entry in the alarm buffer.
- General properties of faults and alarms
 - Triggering on selected messages possible.
 - Contain the component number for identifying the affected SINAMICS component.
 - Contain diagnostic information on the relevant message.

Differences between faults and alarms

Type	BOP display (example)		Status indicator		Reaction	Acknowledgement
			RDY	COM		
Fault		Single fault	Slow flashing in red	-	<ul style="list-style-type: none"> NONE: no reaction OFF1: servo motor ramps down OFF2: servo motor coasts down OFF3: servo motor stops quickly ENCODER: Encoder fault causes OFF2. 	<ul style="list-style-type: none"> POWER ON: re-power on the servo drive to clear a fault after eliminating its cause. IMMEDIATELY: the fault disappears immediately after eliminating its cause. PULSE INHIBIT: The fault can only be acknowledged with a pulse inhibit. The same options are available for acknowledging as described under acknowledgment with IMMEDIATELY.
		The first fault in the case of multiple faults				
		Non-first fault in the case of multiple faults				
Alarm		Single alarm	Slow flashing in red	-	NONE: no reaction	Self-acknowledgement
		The first alarm in the case of multiple alarms				
		Non-first alarm in the case of multiple alarms				

NOTICE

Faults are displayed in prior to alarms

If both faults and alarms occur, faults are displayed in prior to alarms. Alarms are displayed only after all faults have been acknowledged.

BOP operations for faults and alarms

To view faults or alarms, proceed as follows:

- Faults



- Alarms

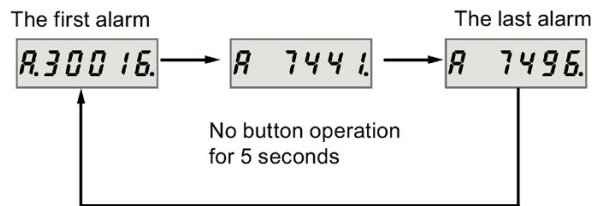

To exit from fault or alarm display, proceed as follows:

- Faults

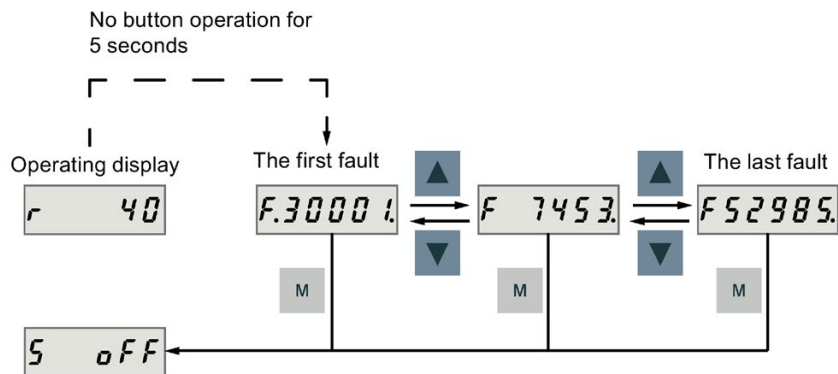

- Alarms

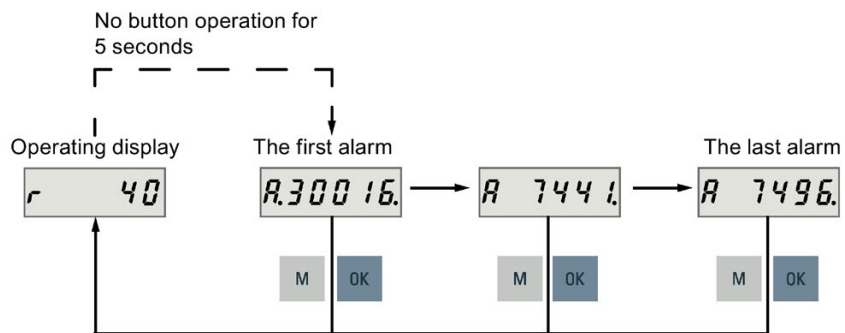

To acknowledge faults, proceed as follows:

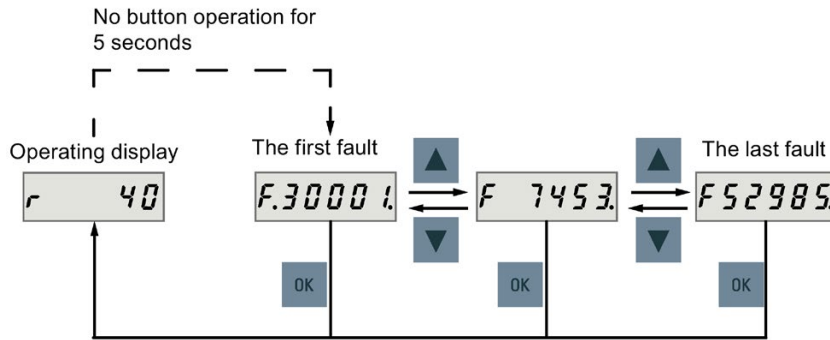

Note

- If you do not eliminate the cause(s) of the fault, it can appear again after no button operation for five seconds. Make sure that you have eliminated the cause(s) of the fault.
- You can acknowledge faults using RESET signal. For details, refer to Operating Instructions.
- You can acknowledge faults on SINAMICS V-ASSISTANT. For details, refer to SINAMICS V-ASSISTANT Online Help.

7.2 List of faults and alarms

This section lists only common faults and alarms. To view the detailed information of all faults and alarms, call the online help for an active fault/alarm in the SINAMICS V-ASSISTANT engineering tool.

Fault list

Fault	Description	Fault	Description
F1000	Internal software error	F7599	Encoder 1: Adjustment not possible
F1001	Floating Point exception	F7800	Drive: No power unit present
F1002	Internal software error	F7801	Motor overcurrent
F1003	Acknowledgment delay when accessing the memory	F7802	Infeed or power unit not ready
F1015	Internal software error	F7815	Power unit has been changed
F1018	Booting has been interrupted several times	F7900	Motor blocked/speed controller at its limit
F1030	Sign-of-life failure for master control	F7901	Motor overspeed
F1611	SI CU: Defect detected	F7995	Motor identification failure
F7011	Motor overtemperature	F30001	Power unit: Overcurrent
F7085	Open-loop/closed-loop control parameters changed	F30002	DC link voltage, overvoltage
F7093	Test signal error	F30003	DC link voltage, undervoltage

Fault	Description	Fault	Description
F7403	Lower DC link voltage threshold reached	F30004	Drive heat sink overtemperature
F7404	Upper DC link voltage threshold reached	F30005	Power unit: Overload I ² t
F7410	Current controller output limited	F30011	Line phase failure in main circuit
F7412	Commutation angle incorrect (motor model)	F30015	Phase failure motor cable
F7420	Drive: Current setpoint filter natural frequency > Shannon frequency	F30021	Ground fault
F7430	Changeover to open-loop torque controlled operation not possible	F30027	Precharging DC link time monitoring
F7431	Changeover to encoderless operation not possible	F30036	Internal overtemperature
F7442	LR: Multiturn does not match the modulo range	F30050	24 V supply overvoltage
F7443	Reference point coordinate not in the permission range	F30071	No new actual values received from the power unit
F7447	Load gear: Position tracking, maximum actual value exceeded	F31100	Zero mark distance error
F7449	Load gear: Position tracking actual position outside the tolerance window	F31101	Zero mark failed
F7450	Standstill monitoring has responded	F31110	Serial communications error
F7451	Position monitoring has responded	F31111	Encoder 1: Absolute encoder internal error
F7452	Following error too high	F31112	Error bit set in the serial protocol
F7453	Position actual value preprocessing error	F31117	Inversion error signals A/B/R
F7458	EPOS: Reference cam not found	F31130	Zero mark and position error from the coarse synchronization
F7459	Zero mark not detected	F31131	Encoder 1: Deviation position incremental/absolute too large
F7460	EPOS: End of reference cam not found	F31150	Initialization error
F7464	EPOS: Traversing block is inconsistent	F52904	Control mode change
F7475	EPOS: Target position < start of traversing range	F52911	Positive torque limitation value error
F7476	EPOS: Target position > end of the traversing range	F52912	Negative torque limitation value error
F7481	EPOS: Axis position < software limit switch minus	F52931	Gear box limit
F7482	EPOS: Axis position > software limit switch plus	F52933	PTO gear box limit
F7484	Fixed stop outside the monitoring window	F52980	Absolute encoder motor changed
F7485	Fixed stop not reached	F52981	Absolute encoder motor mismatched
F7488	EPOS: Relative positioning not possible	F52983	No encoder detected
F7490	Enable signal withdrawn while traversing	F52984	Incremental encoder motor not configured
F7491	STOP cam minus reached	F52985	Absolute encoder motor wrong
F7492	STOP cam plus reached	F52987	Absolute encoder replaced
F7493	LR: Overflow of the value range for position actual value		

Alarm list

Alarm	Description	Alarm	Description
A1009	Control module overtemperature	A7474	EPOS: End of traversing range reached
A1019	Writing to the removable data medium unsuccessful	A7477	EPOS: Target position < software limit switch minus
A1032	All parameters must be saved	A7478	EPOS: Target position > software limit switch plus
A1045	Configuring data invalid	A7479	EPOS: Software limit switch minus reached
A1774	Test stop for fail-safe digital outputs required	A7480	EPOS: Software limit switch plus reached
A1920	Drive Bus: Receive setpoints after To	A7496	SON enable missing
A1932	Drive Bus clock cycle synchronization missing for DSC	A7576	Encoderless operation due to a fault active
A5000	Drive heat sink overtemperature	A7582	Position actual value preprocessing error
A6310	Supply voltage (p29006) incorrectly parameterized	A7585	P-TRG or CLR active
A7012	Motor temperature model 1/3 overtemperature	A7588	Encoder 2: Position value preprocessing does not have a valid encoder
A7092	Drive: Moment of inertia estimator still not ready	A7805	Power unit overload I ² t
A7440	IPos: Jerk time is limited	A7965	Save required
A7441	LR: Save the position offset of the absolute encoder adjustment	A7971	Angular commutation offset determination activated
A7454	LR: Position value preprocessing does not have a valid encoder	A7991	Motor data identification activated
A7455	EPOS: Maximum velocity limited	A30016	Load supply switched off
A7456	EPOS: Setpoint velocity limited	A30031	Hardware current limiting in phase U
A7461	EPOS: Reference point not set	A31411	Absolute encoder signals internal alarms
A7469	EPOS: Traversing block < target position < software limit switch minus	A31412	Error bit set in the serial protocol
A7470	EPOS: Traversing block > target position > software limit switch plus	A52900	Failure during data copying
A7471	EPOS: Traversing block target position outside the modulo range	A52901	Braking resistor reaches alarm threshold
A7472	EPOS: Traversing block ABS_POS/ABS_NEG not possible	A52902	Quick stop (EMGS) missing
A7473	EPOS: Beginning of traversing range reached	A52932	PTO max limit

Index

A

- Accessories
 - Fuse/type E combination motor controller, 26

B

- BOP operations for faults and alarms, 133

C

- Connecting 24 V power supply/STO, 71
- Connecting an external braking resistor, 76
- Connecting the RS485 interface, 77

D

- Differences between faults and alarms, 132
- Drive rating plate, 16

F

- Function list, 28

G

- General information about faults and alarms, 131

L

- LED status indicators, 80

M

- Motor rating plate, 21

O

- Overview of absolute position system, 95
 - Restrictions, 95

P

- Pulse train input position control mode (PTI)
 - In position (INP), 92
 - Selecting a setpoint pulse train input form, 91

S

- System connection, 52

W

- Wiring and connecting
 - Adjusting cable orientations, 58

